

# Nerezové a ocelové spalinové systémy

## CENÍK/CENNÍK

**almeva**<sup>®</sup>  
SWISS GAS FLUE SYSTEMS 



**Platnost od 1.5.2023**  
**Platnosť od 1.5.2023**  
Ceny bez DPH

Designed in  
Switzerland

 Since 1994

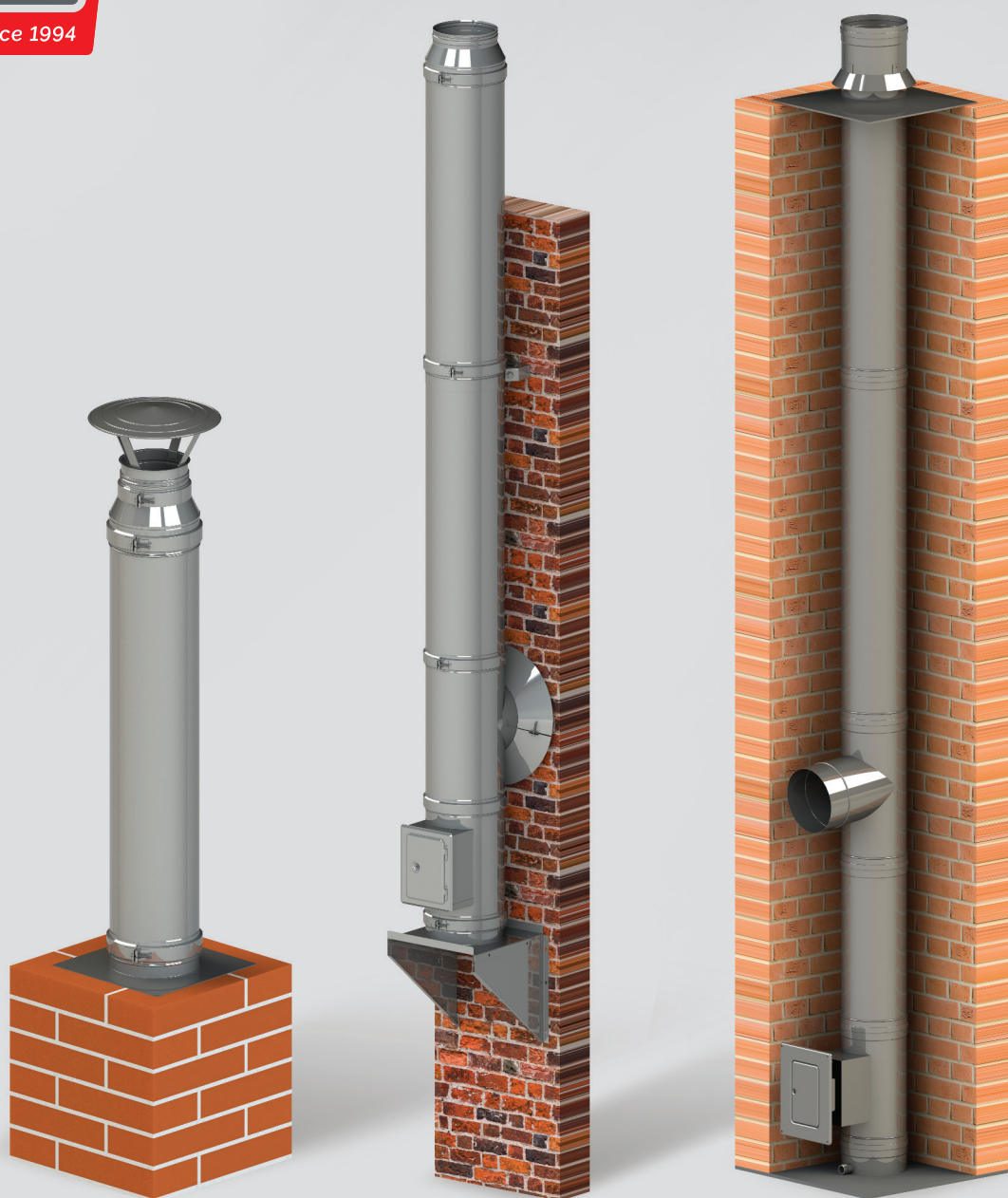

# NEREZOVÝ SYSTÉM ODKOUŘENÍ ALMEVA

## ZÁKLADNÍ CHARAKTERISTIKY SYSTÉMU

### Přednosti

Jedná se o moderní vyspělý systém odvodu spalin, kde léty prověřeným výrobním postupem bylo dosaženo dokonalé přesnosti a kvality všech trubek, tvarovek a ostatního příslušenství. Precizně navržený tvar hrdlového spoje umožňuje vynikající hydraulické vlastnosti potrubí, což zaručuje dokonalé proudění spalin a nízké riziko zanášení.

Těsnění Silikon a EPDM zajišťuje okamžitou vynikající těsnost, pevnost, ale i dlouhodobou pružnost spoje a na rozdíl od jiných typů spojů urychluje a usnadňuje jinak obtížnou kompletaci systému.

Bezproblémová práce, rychlá montáž a snadná revize umožňuje stavebním a montážním firmám vysokou produktivitu práce jak v nové výstavbě, tak i při sanaci stávajících komínových průduchů.

### Použití vzhledem k druhu spotřebiče a typu spalinové cesty

- slouží k odvodu spalin od plynových a olejových spotřebičů a spotřebičů na pevná paliva
- je určen jak pro přetlakové spalinové cesty (tlak uvnitř komínové vložky je během provozu vyšší než vně), tak i pro komíny s přirozeným tahem
- vhodný pro komíny plánovitě provozovány v mokřem i suchém provozním režimu

### Použití vzhledem k místu instalace

- pro novou výstavbu (montáž) komínů
- pro sanace stávajících komínů a komínových průduchů
- možnost aplikace příslušného systému jak v interiéru, tak v exteriéru

### Prvky systému

Nerezové systémy odvodu spalin Almeva disponují řadou komponentů, které jsou nenahraditelnou součástí funkční moderní spalinové cesty. Obsahují přes 200 prvků, kde každý je proveden v různých dimenzích, celkem tedy více než 1700 položek tvořících ucelený spalinový systém.

Díky nespočetnému množství dokonale sladěných komponentů nabízí Almeva široký sortiment nerezového systému odkouření se zaručenou kvalitou.

### Změny vůči předchozímu ceníku ALMEVA z 1.5.2022:

- Systémy EW, DW25, TW25, DK, INOX FLEX G a FB, ASD – zvýšení cen
- Systém PL – ceny beze změn
- Systém ORM – kompletně nový systém:
  - Tloušťka materiálu 2 mm (původně 1,5 mm)
  - Kvalitní barva Senotherm
  - Většina prvků balena v krabicích
  - Snížení ceny v průměru o 20%

## Jednovrstvý nerezový systém (EW)

Nerez		
DN 80 – 600 mm	Vlastnosti a užití systému	4
Tloušťka stěny 0,5 mm DN≤200 mm; 0,6 mm DN≥230 mm≤550 mm; 0,8 mm DN 600 mm	Prvky systému	5-19
Podtlak / přetlak		

## Třívrstvý nerezový systém (DW25)

Nerez / izolace / nerez	Vlastnosti a užití systému	20
DN 80 – 550 mm	Prvky systému	21-37
Tloušťka stěny 0,5 mm DN≤200 mm; 0,6 mm DN≥250 mm	Statické zajištění	38
Tloušťka izolace 25 mm	Variety montáže	39
Tloušťka pláště 0,5 mm DN≤300 mm; 0,6 mm DN≥350 mm	Rozměry úhybů pro dvě kolena a rovné díly	40-41
Podtlak / přetlak	Průchod komínu hořlavými konstrukcemi	42

## Vícevrstvý koncentrický nerezový systém (TW25)

Nerez / izolace / nerez / lakovaná nerez		
DN 150 – 250 mm		
Tloušťka stěny 0,5 mm DN≤200 mm; 0,6 mm DN≥250 mm	Vlastnosti a užití systému	44
Tloušťka izolace 25 mm	Prvky systému	45-56
Tloušťka středního pláště 0,5 mm DN≤300 mm; 0,6 mm DN≥350 mm		
Tloušťka vzduchového mezikruží 25 mm		
Tloušťka vnějšího pláště 0,5 mm DN≤300 mm; 0,6 mm DN≥350 mm		
Podtlak		

## Koncentrický nerezový systém (DK)

Nerez / nerez		
DN 80/125 – 400/600 mm	Vlastnosti a užití systému	58
Tloušťka stěny 0,5 mm DN≤200 mm; 0,6 mm DN≥250 mm	Prvky systému	59-61
Tloušťka pláště 0,5 mm DN≤300 mm; 0,6 mm DN≥350 mm		
Přetlak		

## Jednovrstvý nerezový ohebný systém (INOX FLEX FB)

Nerez		
DN 120 – 200 mm	Vlastnosti a užití systému	62
Tloušťka stěny 0,4 mm – hadice; 0,6 mm – tvarovky	Prvky systému	63
Podtlak		

## Jednovrstvý nerezový ohebný systém (INOX FLEX G)

Nerez		
DN 80 – 300 mm	Vlastnosti a užití systému	64
Tloušťka stěny 0,1 mm – hadice; 0,6 mm – tvarovky	Prvky systému	65-67
Podtlak / přetlak		

## Jednovrstvý ocelový systém (ORM)

Ocel – barva Senotherm		
DN 120 – 200 mm	Vlastnosti a užití systému	68
Tloušťka stěny 2 mm	Prvky systému	69-73
Podtlak		

## Jednovrstvý ocelový systém (PL)

Ocel – černý lak		
DN 80 a 100 mm	Vlastnosti a užití systému	74
Tloušťka stěny 1,2 mm	Prvky systému	75-77
Přetlak		

## Absorpční tlumiče hluku (ASD)

DN 80 – 500 mm	Popis	78
	Prvky systému	79
	Míra tlumení	80

## Ostatní informace

Prohlášení o vlastnostech, komínové štítky	81
Osvědčení o kvalitě	82-83



**EW**

Jednovrstvý nerezový sanační systém, odolný proti vlhkosti, s tloušťkou stěny 0,5 mm s bajonetovým spojováním hrdel a tloušťkou stěny 0,6 mm a 0,8 mm s klasickým hrdlovým spojem.

**Tloušťka stěny:**

0,5 mm DN ≤ 200 mm
0,6 mm DN ≥ 230 mm ≤ 550 mm
0,8 mm DN 600 mm

**Vlastnosti systému:**

- pro olej a plyn
- odolný proti vlhkosti
- při použití těsnění vhodný pro přetlakový provoz
- kapilární drážka proti úniku kondenzátu
- rychlá, jednoduchá a bezpečná montáž
- bohaté příslušenství
- kompatibilní s flexibilními systémy

Nerezový sanační komínový systém **ALMEVA Easy EW** je vhodný pro odvod spalin od všech typů spotřebičů na pevná, olejová a plynná paliva, pracujících v podtlakovém provozu (s přirozeným tahem) a při použití těsnění i v přetlakovém provozu. Je vyroben z ušlechtilé oceli třídy 1.4404. Systém je odolný vůči vlhkosti a umožňuje jak suchý, tak i mokrý provoz.

Široký sortiment prvků umožňuje provedení prakticky jakéhokoli odtahu spalin. Z tohoto systému lze sestavit celou kouřovou cestu (komín i kouřovod). Systém lze propojit s flexibilními systémy.

Výhodou systému je bajonetová hrdlová technika spojování (DN ≤ 200 mm), která garantuje těsnost systému vůči úniku spalin a kondenzátu, bez použití dodatečných spon nebo nýtování.

**Pozn.:**

Zvýrazněné položky v tabulkách jsou skladem.  
Ostatní s dodací lhůtou do 15 pracovních dnů.

Technická data pro <b>ALMEVA Easy EW:</b>	
<b>Třída nerezové oceli: 1.4404 / 316L</b>	
<b>Zatřídění dle EN 1856 - 2:</b>	
EW	EN 1856-2 T600 N1 W V2 L50 (050, 060, 080) G
EW	EN 1856-2 T200 P1 W V2 L50 (050, 060, 080) O (silikonové těsnění)
EW	EN 1856-2 T120 P1 W V2 L50 (050, 060, 080) O (EPDM těsnění)

# JEDNOVRSTVÝ NEREZOVÝ SYSTÉM

## DN 80 – 600 mm

**EW**  
Nerez

Kondenzát. jímka s odtok. do boku	Ød	Kód	Cena [Kč / ks]	Cena [€ / ks]	A (mm)	B (mm)	C (mm)	D (mm)	Hmotnost: [kg / ks]
	80	IVEMAW08	510,-	20,00	-	-	-	-	0,20
	100	IVEMAW10	530,-	20,78	-	-	-	-	0,20
	110	IVEMAW11	609,-	23,88	-	-	-	-	0,30
	120	IVEMAW12	616,-	24,16	-	-	-	-	0,30
	130	IVEMAW13	629,-	24,67	-	-	-	-	0,30
	150	IVEMAW15	648,-	25,41	-	-	-	-	0,30
	160	IVEMAW16	668,-	26,20	-	-	-	-	0,40
	180	IVEMAW18	748,-	29,33	-	-	-	-	0,40
	200	IVEMAW20	780,-	30,59	-	-	-	-	0,50
	230	IVEMAW23	880,-	34,51	-	-	-	-	0,70
	250	IVEMAW25	932,-	36,55	-	-	-	-	0,80
	300	IVEMAW30	1 170,-	45,88	-	-	-	-	1,00
	350	IVEMAW35	1 402,-	54,98	-	-	-	-	1,30
	400	IVEMAW40	1 647,-	64,59	-	-	-	-	1,50
	450	IVEMAW45	1 896,-	74,35	-	-	-	-	1,80
	500	IVEMAW50	2 175,-	85,29	-	-	-	-	2,20
	550	IVEMAW55	2 478,-	97,18	-	-	-	-	2,50
600	IVEMAW60	5 090,-	199,61	-	-	-	-	3,80	

Vynášecí díl EW	Ød	Kód	Cena [Kč / ks]	Cena [€ / ks]	A (mm)	B (mm)	C (mm)	D (mm)	Hmotnost: [kg / ks]
	80	IVEZSU08	990,-	38,82	-	-	-	80	0,82
	100	IVEZSU10	1 010,-	39,61	-	-	-	100	0,87
	110	IVEZSU11	1 020,-	40,00	-	-	-	110	0,89
	120	IVEZSU12	1 064,-	41,73	-	-	-	120	0,92
	130	IVEZSU13	1 087,-	42,63	-	-	-	130	0,92
	150	IVEZSU15	1 202,-	47,14	-	-	-	150	0,99
	160	IVEZSU16	1 263,-	49,53	-	-	-	160	1,04
	180	IVEZSU18	1 357,-	53,22	-	-	-	180	1,11
	200	IVEZSU20	1 482,-	58,12	-	-	-	200	1,19
	230	IVEZSU23	1 733,-	67,96	-	-	-	230	1,60
	250	IVEZSU25	1 852,-	72,63	-	-	-	250	1,68
	300	IVEZSU30	2 206,-	86,51	-	-	-	300	1,96
	350	IVEZSU35	3 144,-	123,29	-	-	-	350	2,20
	400	IVEZSU40	4 022,-	157,73	-	-	-	400	2,48
	450	IVEZSU45	4 587,-	179,88	-	-	-	450	2,75
	500	IVEZSU50	5 351,-	209,84	-	-	-	500	3,01
	550	IVEZSU55	5 993,-	235,02	-	-	-	550	3,29
600	IVEZSU60	8 859,-	347,41	-	-	-	600	3,55	

Záslepka sopouchu	Ød	Kód	Cena [Kč / ks]	Cena [€ / ks]	A (mm)	B (mm)	C (mm)	D (mm)	Hmotnost: [kg / ks]
	80	IVEENU08	337,-	13,22	-	-	-	-	0,12
	100	IVEENU10	359,-	14,08	-	-	-	-	0,16
	110	IVEENU11	364,-	14,27	-	-	-	-	0,17
	120	IVEENU12	378,-	14,82	-	-	-	-	0,19
	130	IVEENU13	392,-	15,37	-	-	-	-	0,21
	150	IVEENU15	418,-	16,39	-	-	-	-	0,25
	160	IVEENU16	436,-	17,10	-	-	-	-	0,27
	180	IVEENU18	642,-	25,18	-	-	-	-	0,32
	200	IVEENU20	675,-	26,47	-	-	-	-	0,37
	230	IVEENU23	721,-	28,27	-	-	-	-	0,53
	250	IVEENU25	768,-	30,12	-	-	-	-	0,60
	300	IVEENU30	1 547,-	60,67	-	-	-	-	0,79
	350	IVEENU35	1 765,-	69,22	-	-	-	-	1,00
	400	IVEENU40	1 896,-	74,35	-	-	-	-	1,23
	450	IVEENU45	2 141,-	83,96	-	-	-	-	1,49
	500	IVEENU50	2 406,-	94,35	-	-	-	-	1,77
	550	IVEENU55	2 683,-	105,22	-	-	-	-	2,08
600	IVEENU60	5 452,-	213,80	-	-	-	-	2,41	

**Pozn.:**

Zvýrazněné položky v tabulkách jsou skladem. Ostatní s dodací lhůtou do 15 pracovních dnů.

Dvířkový díl s vnitř. dvířky (podtlak)	Ød	Kód	Cena [Kč / ks]	Cena [€ / ks]	A (mm)	B (mm)	C (mm)	D (mm)	Hmotnost: [kg / ks]
	80	-	-	-	-	-	-	-	-
	100	-	-	-	-	-	-	-	-
	110	IVEFT911	1 468,-	57,57	325	-	-	-	0,94
	120	IVEFT912	1 230,-	48,24	325	-	-	-	0,97
	130	IVEFT913	1 237,-	48,51	325	-	-	-	0,97
	150	IVEFT915	1 262,-	49,49	325	-	-	-	1,04
	160	IVEFT916	1 283,-	50,31	325	-	-	-	1,09
	180	IVEFT918	1 355,-	53,14	325	-	-	-	1,17
	200	IVEFT920	1 402,-	54,98	325	-	-	-	1,25
	230	IVEFT923	1 652,-	64,78	325	-	-	-	1,68
	250	IVEFT925	1 719,-	67,41	325	-	-	-	1,77
	300	IVEFT930	2 002,-	78,51	325	-	-	-	2,06
	350	IVEFT935	2 564,-	100,55	325	-	-	-	2,32
	400	IVEFT940	2 624,-	102,90	325	-	-	-	2,61
	450	IVEFT945	2 676,-	104,94	325	-	-	-	2,89
	500	IVEFT950	2 728,-	106,98	325	-	-	-	3,17
	550	IVEFT955	3 276,-	128,47	325	-	-	-	3,46
600	IVEFT960	6 888,-	270,12	325	-	-	-	3,74	

Komínová dvířka (podtlak)	Ød	Kód	Cena [Kč / ks]	Cena [€ / ks]	A (mm)	B (mm)	C (mm)	D (mm)	Hmotnost: [kg / ks]
	80	-	-	-	-	-	-	-	-
	100	-	-	-	-	-	-	-	-
	110	IVEFDH22	1 686,-	66,12	-	-	-	-	0,96
	120								
	130								
	150								
	160								
	180								
	200								
	230								
	250								
	300								
	350								
	400								
	450								
500									
550									
600									

Komínová dvířka s prodl. (podtlak)	Ød	Kód	Cena [Kč / ks]	Cena [€ / ks]	A (mm)	B (mm)	C (mm)	D (mm)	Hmotnost: [kg / ks]
	80	-	-	-	-	-	-	-	-
	100	-	-	-	-	-	-	-	-
	110	IVEFDL22	2 312,-	90,67	-	-	-	-	1,62
	120								
	130								
	150								
	160								
	180								
	200								
	230								
	250								
	300								
	350								
	400								
	450								
500									
550									
600									

**Pozn.:**

Zvýrazněné položky v tabulkách jsou skladem. Ostatní s dodací lhůtou do 15 pracovních dnů.

# JEDNOVRSTVÝ NEREZOVÝ SYSTÉM

## DN 80 – 600 mm

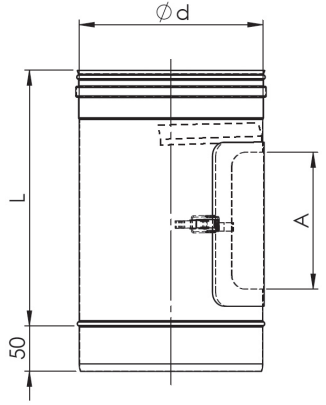
Revizní rovný díl	Ød	Kód	Cena [Kč / ks]	Cena [€ / ks]	A (mm)	L (mm)	C (mm)	D (mm)	Hmotnost: [kg / ks]
	80	IVERR008	748,-	29,33	70	240	-	-	0,37
	100	IVERR010	808,-	31,69	80	250	-	-	0,48
	110	IVERR011	826,-	32,39	90	260	-	-	0,53
	120	IVERR012	880,-	34,51	100	270	-	-	0,61
	130	IVERR013	921,-	36,12	110	280	-	-	0,69
	150	IVERR015	1 045,-	40,98	130	300	-	-	0,85
	160	IVERR016	1 071,-	42,00	130	300	-	-	0,90
	180	IVERR018	1 196,-	46,90	150	320	-	-	1,08
	200	IVERR020	1 251,-	49,06	150	320	-	-	1,19
	230	IVERR023	1 580,-	61,96	170	340	-	-	1,73
	250	IVERR025	1 692,-	66,35	180	350	-	-	1,93
	300	IVERR030	1 983,-	77,76	200	370	-	-	2,44
	350	IVERR035	2 418,-	94,82	200	370	-	-	2,83
	400	IVERR040	3 285,-	128,82	250	420	-	-	3,65
	450	IVERR045	3 562,-	139,69	250	420	-	-	4,11
	500	IVERR050	4 116,-	161,41	300	470	-	-	5,09
550	IVERR055	4 480,-	175,69	300	470	-	-	5,59	
600	IVERR060	8 354,-	327,61	300	470	-	-	6,11	

Pozn.: Pro přetlak nutno použít těsnění U pod víčko

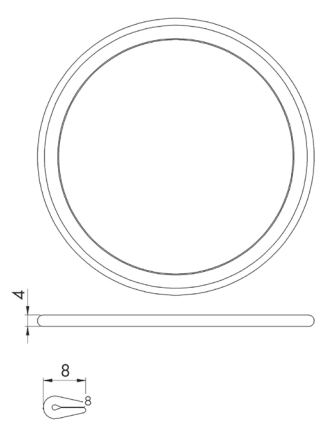
Těsnění U pro revizní rovný díl	Ød	Kód	Cena [Kč / ks]	Cena [€ / ks]	A (mm)	B (mm)	C (mm)	D (mm)	Hmotnost: [kg / ks]
	80	IVEMDI08	277,-	10,86	-	-	-	-	0,01
	100	IVEMDI10	292,-	11,45	-	-	-	-	0,01
	110	IVEMDI11	326,-	12,78	-	-	-	-	0,01
	120	IVEMDI12	340,-	13,33	-	-	-	-	0,01
	130	IVEMDI13	360,-	14,12	-	-	-	-	0,01
	150	IVEMDI15	387,-	15,18	-	-	-	-	0,01
	160	IVEMDI16	401,-	15,73	-	-	-	-	0,01
	180	IVEMDI18	422,-	16,55	-	-	-	-	0,01
	200	IVEMDI20	436,-	17,10	-	-	-	-	0,01
	230	IVEMDI23	464,-	18,20	-	-	-	-	0,01
	250	IVEMDI25	484,-	18,98	-	-	-	-	0,02
	300	IVEMDI30	519,-	20,35	-	-	-	-	0,02
	350	IVEMDI35	533,-	20,90	-	-	-	-	0,02
	400	IVEMDI40	609,-	23,88	-	-	-	-	0,02
	450	IVEMDI45	629,-	24,67	-	-	-	-	0,02
	500	IVEMDI50	698,-	27,37	-	-	-	-	0,03
550	IVEMDI55	712,-	27,92	-	-	-	-	0,03	
600	IVEMDI60	726,-	28,47	-	-	-	-	0,03	

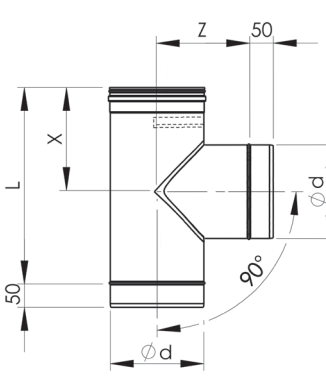
Sopouch 90°	Ød	Kód	Cena [Kč / ks]	Cena [€ / ks]	L (mm)	Z (mm)	X (mm)	D (mm)	Hmotnost: [kg / ks]
	80	-	-	-	-	-	-	-	-
	100	-	-	-	-	-	-	-	-
	110	-	-	-	-	-	-	-	-
	120	-	-	-	-	-	-	-	-
	130	-	-	-	-	-	-	-	-
	150	IVETE915	1 309,-	51,33	370	175	188	-	1,05
	160	-	-	-	-	-	-	-	-
	180	IVETE918	1 521,-	59,65	400	190	202	-	1,32
	200	IVETE920	1 638,-	64,24	420	200	211	-	1,53
	230	-	-	-	-	-	-	-	-
	250	-	-	-	-	-	-	-	-
	300	-	-	-	-	-	-	-	-
	350	-	-	-	-	-	-	-	-
	400	-	-	-	-	-	-	-	-
	450	-	-	-	-	-	-	-	-
	500	-	-	-	-	-	-	-	-
550	-	-	-	-	-	-	-	-	
600	-	-	-	-	-	-	-	-	

**Pozn.:**

Zvýrazněné položky v tabulkách jsou skladem. Ostatní s dodací lhůtou do 15 pracovních dnů.

Sopouch 85°	Ød	Kód	Cena [Kč / ks]	Cena [€ / ks]	L (mm)	Z (mm)	X (mm)	D (mm)	Hmotnost: [kg / ks]
	80	IVETE808	998,-	39,14	310	148	162	-	0,49
	100	IVETE810	1 144,-	44,86	320	150	166	-	0,63
	110	IVETE811	1 170,-	45,88	330	155	170	-	0,71
	120	IVETE812	1 190,-	46,67	340	160	175	-	0,79
	130	IVETE813	1 210,-	47,45	350	165	179	-	0,87
	150	IVETE815	1 309,-	51,33	370	175	188	-	1,05
	160	IVETE816	1 389,-	54,47	380	180	193	-	1,13
	180	IVETE818	1 521,-	59,65	400	190	202	-	1,32
	200	IVETE820	1 638,-	64,24	420	200	211	-	1,53
	230	IVETE823	2 036,-	79,84	450	215	225	-	2,23
	250	IVETE825	2 188,-	85,80	470	225	234	-	2,51
	300	IVETE830	2 703,-	106,00	520	250	257	-	3,27
	350	IVETE835	3 463,-	135,80	570	275	280	-	4,42
	400	IVETE840	4 512,-	176,94	620	300	303	-	5,07
	450	IVETE845	5 324,-	208,78	670	325	325	-	6,10
	500	IVETE850	6 191,-	242,78	720	350	348	-	7,22
	550	IVETE855	7 129,-	279,57	770	375	371	-	8,44
600	IVETE860	15 382,-	603,22	820	400	394	-	13,00	

Sopouch 45°	Ød	Kód	Cena [Kč / ks]	Cena [€ / ks]	L (mm)	Z (mm)	X (mm)	D (mm)	Hmotnost: [kg / ks]
	80	IVETE408	1 540,-	60,39	344	201	142	-	0,73
	100	IVETE410	1 679,-	65,84	360	220	141	-	0,77
	110	IVETE411	1 799,-	70,55	374	232	143	-	0,88
	120	IVETE412	1 844,-	72,31	388	244	145	-	0,98
	130	IVETE413	1 943,-	76,20	402	256	147	-	1,10
	150	IVETE415	2 280,-	89,41	430	280	151	-	1,34
	160	IVETE416	2 571,-	100,82	444	292	153	-	1,47
	180	IVETE418	2 756,-	108,08	472	316	157	-	1,74
	200	IVETE420	3 106,-	121,80	500	340	161	-	2,04
	230	IVETE423	3 417,-	134,00	542	376	167	-	3,02
	250	IVETE425	3 621,-	142,00	570	400	171	-	3,44
	300	IVETE430	4 280,-	167,84	640	460	181	-	4,59
	350	IVETE435	4 664,-	182,90	710	520	191	-	5,91
	400	IVETE440	6 771,-	265,53	780	580	201	-	7,37
	450	IVETE445	7 616,-	298,67	850	640	211	-	9,00
	500	IVETE450	8 687,-	340,67	920	700	221	-	10,79
	550	IVETE455	10 112,-	396,55	990	760	231	-	12,73
600	IVETE460	21 376,-	838,27	1060	820	241	-	19,78	

Sopouch pro vložkování 85° (podtlak)	Ød	Kód	Cena [Kč / ks]	Cena [€ / ks]	L (mm)	Z (mm)	X (mm)	D (mm)	Hmotnost: [kg / ks]
	80	IVETEU08	1 090,-	42,75	310	148	162	-	0,49
	100	IVETEU10	1 210,-	47,45	320	150	166	-	0,63
	110	IVETEU11	1 277,-	50,08	330	155	170	-	0,71
	120	IVETEU12	1 349,-	52,90	340	160	175	-	0,79
	130	IVETEU13	1 389,-	54,47	350	165	179	-	0,87
	150	IVETEU15	1 521,-	59,65	370	175	188	-	1,05
	160	IVETEU16	1 600,-	62,75	380	180	193	-	1,13
	180	IVETEU18	1 679,-	65,84	400	190	202	-	1,32
	200	IVETEU20	2 148,-	84,24	420	200	211	-	1,53
	230	IVETEU23	2 974,-	116,63	450	215	225	-	2,23
	250	IVETEU25	3 099,-	121,53	470	225	234	-	2,51
	300	IVETEU30	3 455,-	135,49	520	250	257	-	3,27
	350	-	-	-	-	-	-	-	-
	400	-	-	-	-	-	-	-	-
	450	-	-	-	-	-	-	-	-
	500	-	-	-	-	-	-	-	-
	550	-	-	-	-	-	-	-	-
600	-	-	-	-	-	-	-	-	

**Pozn.:**

Zvýrazněné položky v tabulkách jsou skladem. Ostatní s dodací lhůtou do 15 pracovních dnů.



# JEDNOVRSTVÝ NEREZOVÝ SYSTÉM

## DN 80 – 600 mm

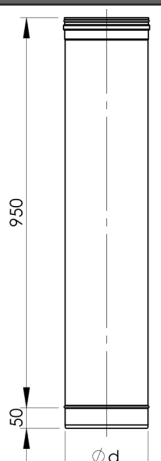
Rovný díl 950mm	Ød	Kód	Cena [Kč / ks]	Cena [€ / ks]	A (mm)	B (mm)	C (mm)	D (mm)	Hmotnost: [kg / ks]
	80	IVERM108	675,-	26,47	-	-	-	-	1,01
	100	IVERM110	780,-	30,59	-	-	-	-	1,26
	110	IVERM111	826,-	32,39	-	-	-	-	1,38
	120	IVERM112	866,-	33,96	-	-	-	-	1,51
	130	IVERM113	932,-	36,55	-	-	-	-	1,63
	150	IVERM115	1 090,-	42,75	-	-	-	-	1,88
	160	IVERM116	1 130,-	44,31	-	-	-	-	2,01
	180	IVERM118	1 210,-	47,45	-	-	-	-	2,26
	200	IVERM120	1 295,-	50,78	-	-	-	-	2,51
	230	IVERM123	1 652,-	64,78	-	-	-	-	3,47
	250	IVERM125	1 790,-	70,20	-	-	-	-	3,77
	300	IVERM130	2 135,-	83,73	-	-	-	-	4,52
	350	IVERM135	2 564,-	100,55	-	-	-	-	5,28
	400	IVERM140	3 270,-	128,24	-	-	-	-	6,03
	450	IVERM145	3 647,-	143,02	-	-	-	-	6,79
	500	IVERM150	4 024,-	157,80	-	-	-	-	7,54
550	IVERM155	4 407,-	172,82	-	-	-	-	8,29	
600	IVERM160	7 189,-	281,92	-	-	-	-	12,06	

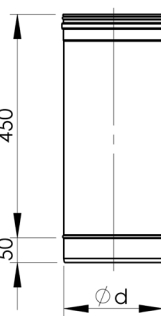
Rovný díl 450mm	Ød	Kód	Cena [Kč / ks]	Cena [€ / ks]	A (mm)	B (mm)	C (mm)	D (mm)	Hmotnost: [kg / ks]
	80	IVERM508	384,-	15,06	-	-	-	-	0,51
	100	IVERM510	464,-	18,20	-	-	-	-	0,63
	110	IVERM511	470,-	18,43	-	-	-	-	0,69
	120	IVERM512	484,-	18,98	-	-	-	-	0,76
	130	IVERM513	510,-	20,00	-	-	-	-	0,82
	150	IVERM515	582,-	22,82	-	-	-	-	0,94
	160	IVERM516	616,-	24,16	-	-	-	-	1,01
	180	IVERM518	675,-	26,47	-	-	-	-	1,13
	200	IVERM520	734,-	28,78	-	-	-	-	1,26
	230	IVERM523	900,-	35,29	-	-	-	-	1,74
	250	IVERM525	966,-	37,88	-	-	-	-	1,89
	300	IVERM530	1 151,-	45,14	-	-	-	-	2,26
	350	IVERM535	1 402,-	54,98	-	-	-	-	2,64
	400	IVERM540	1 725,-	67,65	-	-	-	-	3,02
	450	IVERM545	1 996,-	78,27	-	-	-	-	3,40
	500	IVERM550	2 200,-	86,27	-	-	-	-	3,77
550	IVERM555	2 406,-	94,35	-	-	-	-	4,15	
600	IVERM560	3 810,-	149,41	-	-	-	-	6,03	

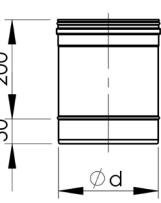
Rovný díl 200mm	Ød	Kód	Cena [Kč / ks]	Cena [€ / ks]	A (mm)	B (mm)	C (mm)	D (mm)	Hmotnost: [kg / ks]
	80	IVERM008	239,-	9,37	-	-	-	-	0,25
	100	IVERM010	272,-	10,67	-	-	-	-	0,32
	110	IVERM011	279,-	10,94	-	-	-	-	0,35
	120	IVERM012	299,-	11,73	-	-	-	-	0,38
	130	IVERM013	319,-	12,51	-	-	-	-	0,41
	150	IVERM015	364,-	14,27	-	-	-	-	0,47
	160	IVERM016	371,-	14,55	-	-	-	-	0,50
	180	IVERM018	431,-	16,90	-	-	-	-	0,57
	200	IVERM020	457,-	17,92	-	-	-	-	0,63
	230	IVERM023	510,-	20,00	-	-	-	-	0,87
	250	IVERM025	550,-	21,57	-	-	-	-	0,94
	300	IVERM030	648,-	25,41	-	-	-	-	1,13
	350	IVERM035	808,-	31,69	-	-	-	-	1,32
	400	IVERM040	986,-	38,67	-	-	-	-	1,51
	450	IVERM045	1 151,-	45,14	-	-	-	-	1,70
	500	IVERM050	1 309,-	51,33	-	-	-	-	1,89
550	IVERM055	1 474,-	57,80	-	-	-	-	2,07	
600	IVERM060	2 480,-	97,25	-	-	-	-	3,02	

**Pozn.:**

Zvýrazněné položky v tabulkách jsou skladem. Ostatní s dodací lhůtou do 15 pracovních dnů.

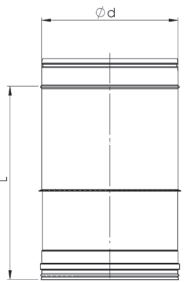
Nastav. díl kouř. 300-450mm	Ød	Kód	Cena [Kč / ks]	Cena [€ / ks]	L (mm)	B (mm)	C (mm)	D (mm)	Hmotnost: [kg / ks]
	80	IVERS508	768,-	30,12	300-450	-	-	-	0,56
	100	IVERS510	928,-	36,39	300-450	-	-	-	0,69
	110	IVERS511	939,-	36,82	300-450	-	-	-	0,76
	120	IVERS512	968,-	37,96	300-450	-	-	-	0,84
	130	IVERS513	1 020,-	40,00	300-450	-	-	-	0,90
	150	IVERS515	1 163,-	45,61	300-450	-	-	-	1,03
	160	IVERS516	1 232,-	48,31	300-450	-	-	-	1,11
	180	IVERS518	1 350,-	52,94	300-450	-	-	-	1,24
	200	IVERS520	1 467,-	57,53	300-450	-	-	-	1,39
	230	IVERS523	1 800,-	70,59	300-450	-	-	-	1,91
	250	IVERS525	1 931,-	75,73	300-450	-	-	-	2,08
	300	IVERS530	2 301,-	90,24	300-450	-	-	-	2,49
	-	-	-	-	-	-	-	-	-
	-	-	-	-	-	-	-	-	-

Pozn.: Pro přetlak nutno použít těsnění Silikon nebo EPDM pro posuvnou část

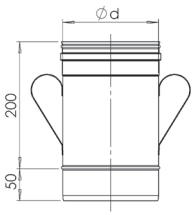
Rovný díl 200mm spouštěcí	Ød	Kód	Cena [Kč / ks]	Cena [€ / ks]	A (mm)	B (mm)	C (mm)	D (mm)	Hmotnost: [kg / ks]
	80	IVERA080	656,-	25,73	-	-	-	-	0,30
	100	IVERA010	682,-	26,75	-	-	-	-	0,36
	110	IVERA011	695,-	27,25	-	-	-	-	0,40
	120	IVERA012	709,-	27,80	-	-	-	-	0,43
	130	IVERA013	721,-	28,27	-	-	-	-	0,46
	150	IVERA015	748,-	29,33	-	-	-	-	0,52
	160	IVERA016	761,-	29,84	-	-	-	-	0,55
	180	IVERA018	913,-	35,80	-	-	-	-	0,62
	200	IVERA020	940,-	36,86	-	-	-	-	0,68
	230	IVERA023	1 005,-	39,41	-	-	-	-	0,92
	250	IVERA025	1 053,-	41,29	-	-	-	-	0,99
	300	IVERA030	1 125,-	44,12	-	-	-	-	1,18
	350	IVERA035	1 190,-	46,67	-	-	-	-	1,37
	400	IVERA040	1 851,-	72,59	-	-	-	-	1,56

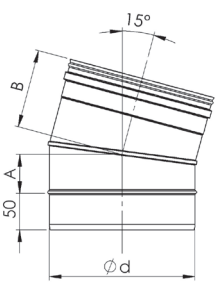
Koleno 15°	Ød	Kód	Cena [Kč / ks]	Cena [€ / ks]	A (mm)	B (mm)	C (mm)	D (mm)	Hmotnost: [kg / ks]
	80	IVESB108	436,-	17,10	45	95	-	-	0,19
	100	IVESB110	477,-	18,71	47	97	-	-	0,24
	110	IVESB111	503,-	19,73	47	97	-	-	0,27
	120	IVESB112	510,-	20,00	48	98	-	-	0,30
	130	IVESB113	530,-	20,78	49	99	-	-	0,32
	150	IVESB115	648,-	25,41	50	100	-	-	0,38
	160	IVESB116	668,-	26,20	51	101	-	-	0,40
	180	IVESB118	709,-	27,80	52	102	-	-	0,46
	200	IVESB120	748,-	29,33	53	103	-	-	0,52
	230	IVESB123	946,-	37,10	55	105	-	-	0,73
	250	IVESB125	1 045,-	40,98	56	106	-	-	0,80
	300	IVESB130	1 289,-	50,55	60	110	-	-	0,99
	350	IVESB135	1 647,-	64,59	63	113	-	-	1,19
	400	IVESB140	2 795,-	109,61	66	116	-	-	1,40

**Pozn.:**

Zvýrazněné položky v tabulkách jsou skladem. Ostatní s dodací lhůtou do 15 pracovních dnů.

# JEDNOVRSTVÝ NEREZOVÝ SYSTÉM

## DN 80 – 600 mm

Koleno 30°	Ød	Kód	Cena [Kč / ks]	Cena [€ / ks]	A (mm)	B (mm)	C (mm)	D (mm)	Hmotnost: [kg / ks]
	80	IVESB308	436,-	17,10	51	101	-	-	0,25
	100	IVESB310	477,-	18,71	53	103	-	-	0,32
	110	IVESB311	503,-	19,73	55	105	-	-	0,36
	120	IVESB312	510,-	20,00	56	106	-	-	0,36
	130	IVESB313	530,-	20,78	57	107	-	-	0,36
	150	IVESB315	648,-	25,41	60	110	-	-	0,52
	160	IVESB316	668,-	26,20	61	111	-	-	0,57
	180	IVESB318	709,-	27,80	64	114	-	-	0,66
	200	IVESB320	748,-	29,33	67	117	-	-	0,74
	230	IVESB323	946,-	37,10	71	121	-	-	1,06
	250	IVESB325	1 045,-	40,98	74	124	-	-	1,19
	300	IVESB330	1 289,-	50,55	80	130	-	-	1,53
	350	IVESB335	1 647,-	64,59	87	137	-	-	1,91
	400	IVESB340	2 795,-	109,61	94	144	-	-	2,33
	450	IVESB345	3 106,-	121,80	100	150	-	-	2,78
	500	IVESB350	3 639,-	142,71	110	160	-	-	3,27
550	IVESB355	3 865,-	151,57	115	165	-	-	3,79	
600	IVESB360	5 013,-	196,59	120	170	-	-	5,81	

Koleno 45°	Ød	Kód	Cena [Kč / ks]	Cena [€ / ks]	A (mm)	B (mm)	C (mm)	D (mm)	Hmotnost: [kg / ks]
	80	IVESB408	457,-	17,92	164	89	119	69	0,28
	100	IVESB410	516,-	20,24	171	92	123	73	0,36
	110	IVESB411	543,-	21,29	175	93	125	75	0,40
	120	IVESB412	550,-	21,57	178	95	127	77	0,45
	130	IVESB413	582,-	22,82	182	96	129	79	0,49
	150	IVESB415	695,-	27,25	189	99	133	82	0,58
	160	IVESB416	780,-	30,59	193	101	135	84	0,63
	180	IVESB418	826,-	32,39	200	103	139	88	0,72
	200	IVESB420	880,-	34,51	220	112	143	92	0,81
	230	IVESB423	1 190,-	46,67	231	116	158	106	1,23
	250	IVESB425	1 295,-	50,78	238	119	162	111	1,37
	300	IVESB430	1 606,-	62,98	256	127	172	120	1,74
	350	IVESB435	1 988,-	77,96	274	134	182	130	2,16
	400	IVESB440	3 297,-	129,29	291	141	191	139	2,61
	450	IVESB445	3 666,-	143,76	309	149	201	149	3,09
	500	IVESB450	4 280,-	167,84	327	156	210	159	3,61
550	IVESB455	4 744,-	186,04	344	163	220	168	4,17	
600	IVESB460	7 089,-	278,00	362	171	230	178	6,36	

Koleno 85°	Ød	Kód	Cena [Kč / ks]	Cena [€ / ks]	A (mm)	B (mm)	C (mm)	D (mm)	Hmotnost: [kg / ks]
	80	IVESB808	656,-	25,73	138	172	-	-	0,33
	100	IVESB810	794,-	31,14	148	181	-	-	0,43
	110	IVESB811	826,-	32,39	153	186	-	-	0,48
	120	IVESB812	846,-	33,18	158	190	-	-	0,53
	130	IVESB813	873,-	34,24	163	195	-	-	0,59
	150	IVESB815	1 085,-	42,55	173	204	-	-	0,70
	160	IVESB816	1 110,-	43,53	178	208	-	-	0,76
	180	IVESB818	1 230,-	48,24	188	217	-	-	0,88
	200	IVESB820	1 408,-	55,22	219	246	-	-	0,99
	230	IVESB823	1 600,-	62,75	234	260	-	-	1,57
	250	IVESB825	1 706,-	66,90	244	269	-	-	1,75
	300	IVESB830	2 102,-	82,43	269	292	-	-	2,26
	350	IVESB835	2 610,-	102,35	294	314	-	-	2,81
	400	IVESB840	4 942,-	193,80	319	337	-	-	3,42
	450	IVESB845	5 807,-	227,73	344	360	-	-	4,08
	500	IVESB850	6 612,-	259,29	368	383	-	-	4,79
550	IVESB855	7 465,-	292,75	394	406	-	-	5,56	
600	IVESB860	11 707,-	459,10	418	428	-	-	8,50	

**Pozn.:**

Zvýrazněné položky v tabulkách jsou skladem. Ostatní s dodací lhůtou do 15 pracovních dnů.

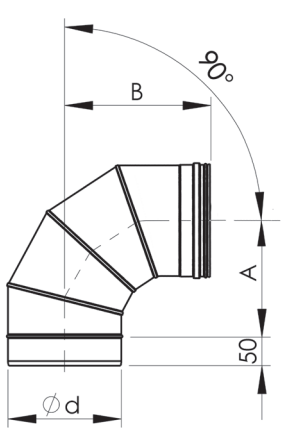
Koleno 90°	Ød	Kód	Cena [Kč / ks]	Cena [€ / ks]	A (mm)	B (mm)	C (mm)	D (mm)	Hmotnost: [kg / ks]
	80	IVESB908	656,-	25,73	138	172	-	-	0,33
	100	IVESB910	794,-	31,14	148	181	-	-	0,43
	110	IVESB911	826,-	32,39	153	186	-	-	0,48
	120	IVESB912	846,-	33,18	158	190	-	-	0,53
	130	IVESB913	873,-	34,24	163	195	-	-	0,59
	150	IVESB915	1 085,-	42,55	173	204	-	-	0,70
	160	IVESB916	1 110,-	43,53	178	208	-	-	0,76
	180	IVESB918	1 230,-	48,24	188	217	-	-	0,88
	200	IVESB920	1 408,-	55,22	219	246	-	-	0,99
	230	IVESB923	1 600,-	62,75	234	260	-	-	1,57
	250	IVESB925	1 706,-	66,90	244	269	-	-	1,75
	300	IVESB930	2 102,-	82,43	269	292	-	-	2,26
	350	IVESB935	2 610,-	102,35	294	314	-	-	2,81
	400	IVESB940	4 942,-	193,80	319	337	-	-	3,42
	450	IVESB945	5 807,-	227,73	344	360	-	-	4,08
	500	IVESB950	6 612,-	259,29	368	383	-	-	4,79
550	IVESB955	7 465,-	292,75	394	406	-	-	5,56	
600	IVESB960	11 707,-	459,10	418	428	-	-	8,50	

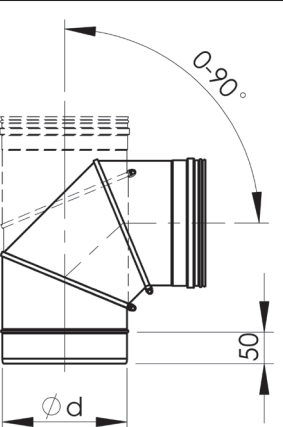
Koleno 0-90° nastav. (podtlak)	Ød	Kód	Cena [Kč / ks]	Cena [€ / ks]	A (mm)	B (mm)	C (mm)	D (mm)	Hmotnost: [kg / ks]
	80	IVEVB908	1 078,-	42,27	-	-	-	-	0,33
	100	IVEVB910	1 151,-	45,14	-	-	-	-	0,43
	110	IVEVB911	1 163,-	45,61	-	-	-	-	0,48
	120	IVEVB912	1 185,-	46,47	-	-	-	-	0,53
	130	IVEVB913	1 217,-	47,73	-	-	-	-	0,59
	150	IVEVB915	1 303,-	51,10	-	-	-	-	0,70
	160	IVEVB916	1 355,-	53,14	-	-	-	-	0,76
	180	IVEVB918	1 448,-	56,78	-	-	-	-	0,88
	200	IVEVB920	1 554,-	60,94	-	-	-	-	0,99
	230	IVEVB923	1 922,-	75,37	-	-	-	-	1,57
	250	IVEVB925	2 063,-	80,90	-	-	-	-	1,75
	300	IVEVB930	2 439,-	95,65	-	-	-	-	2,26
	350	-	-	-	-	-	-	-	-
	400	-	-	-	-	-	-	-	-
	450	-	-	-	-	-	-	-	-
	500	-	-	-	-	-	-	-	-
550	-	-	-	-	-	-	-	-	
600	-	-	-	-	-	-	-	-	

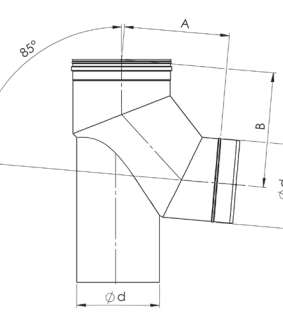
Patní koleno 85°	Ød	Kód	Cena [Kč / ks]	Cena [€ / ks]	A (mm)	B (mm)	C (mm)	D (mm)	Hmotnost: [kg / ks]
	80	IVEFB808	1 355,-	53,14	159	191	-	-	0,42
	100	IVEFB810	1 506,-	59,06	179	210	-	-	0,64
	110	IVEFB811	1 620,-	63,53	189	219	-	-	0,75
	120	IVEFB812	1 600,-	62,75	199	228	-	-	0,86
	130	IVEFB813	1 686,-	66,12	209	238	-	-	0,99
	150	IVEFB815	1 851,-	72,59	230	256	-	-	1,27
	160	IVEFB816	1 936,-	75,92	240	266	-	-	1,42
	180	IVEFB818	2 128,-	83,45	260	284	-	-	1,74
	200	IVEFB820	2 312,-	90,67	281	303	-	-	2,08
	230	IVEFB823	3 026,-	118,67	311	331	-	-	3,19
	250	IVEFB825	3 297,-	129,29	331	349	-	-	3,51
	300	IVEFB830	4 044,-	158,59	382	396	-	-	4,72
	350	IVEFB835	5 101,-	200,04	433	443	-	-	6,35
	400	IVEFB840	6 678,-	261,88	484	489	-	-	8,07
	450	IVEFB845	7 808,-	306,20	535	536	-	-	10,12
	500	IVEFB850	9 004,-	353,10	585	582	-	-	11,74
550	IVEFB855	10 291,-	403,57	636	629	-	-	14,00	
600	IVEFB860	14 823,-	581,29	687	675	-	-	16,44	

### Pozn.:

Zvýrazněné položky v tabulkách jsou skladem. Ostatní s dodací lhůtou do 15 pracovních dnů.

# JEDNOVRSTVÝ NEREZOVÝ SYSTÉM

## DN 80 – 600 mm

Revizní koleno 85°	Ød	Kód	Cena [Kč / ks]	Cena [€ / ks]	A (mm)	B (mm)	C (mm)	D (mm)	Hmotnost: [kg / ks]
	80	IVEVBR08	921,-	36,12	121	164	60	-	0,36
	100	IVEVBR10	1 025,-	40,20	139	183	70	-	0,48
	110	IVEVBR11	1 071,-	42,00	148	192	80	-	0,55
	120	IVEVBR12	1 110,-	43,53	157	202	80	-	0,61
	130	IVEVBR13	1 151,-	45,14	166	213	100	-	0,69
	150	IVEVBR15	1 474,-	57,80	184	234	130	-	0,86
	160	IVEVBR16	1 506,-	59,06	184	235	130	-	0,93
	180	IVEVBR18	1 586,-	62,20	186	236	130	-	1,08
	200	IVEVBR20	1 667,-	65,37	188	236	130	-	1,25
	230	IVEVBR23	1 838,-	72,08	215	262	150	-	1,92
	250	IVEVBR25	2 095,-	82,16	216	262	150	-	2,15
	300	IVEVBR30	2 425,-	95,10	235	281	150	-	2,79
	350	IVEVBR35	3 574,-	140,16	259	283	150	-	3,51
	400	IVEVBR40	5 378,-	210,90	284	306	200	-	4,24
	450	IVEVBR45	6 414,-	251,53	309	329	250	-	5,23
	500	IVEVBR50	7 253,-	284,43	334	352	300	-	6,32
550	IVEVBR55	7 545,-	295,88	359	374	300	-	7,35	
600	IVEVBR60	9 743,-	382,08	384	397	300	-	8,46	

Pozn.: Pro přetlak nutno použít těsnění U pod víčko

Revizní koleno 90°	Ød	Kód	Cena [Kč / ks]	Cena [€ / ks]	A (mm)	B (mm)	C (mm)	D (mm)	Hmotnost: [kg / ks]
	80	IVERBR08	921,-	36,12	121	164	60	-	0,36
	100	IVERBR10	1 025,-	40,20	139	183	70	-	0,48
	110	IVERBR11	1 071,-	42,00	148	192	80	-	0,55
	120	IVERBR12	1 110,-	43,53	157	202	80	-	0,61
	130	IVERBR13	1 151,-	45,14	166	213	100	-	0,69
	150	IVERBR15	1 474,-	57,80	184	234	130	-	0,86
	160	IVERBR16	1 506,-	59,06	184	235	130	-	0,93
	180	IVERBR18	1 586,-	62,20	186	236	130	-	1,08
	200	IVERBR20	1 667,-	65,37	188	236	130	-	1,25
	230	IVERBR23	1 838,-	72,08	215	262	150	-	1,92
	250	IVERBR25	2 095,-	82,16	216	262	150	-	2,15
	300	IVERBR30	2 425,-	95,10	235	281	150	-	2,79
	350	IVERBR35	3 574,-	140,16	259	283	150	-	3,51
	400	IVERBR40	5 378,-	210,90	284	306	200	-	4,24
	450	IVERBR45	6 414,-	251,53	309	329	250	-	5,23
	500	IVERBR50	7 253,-	284,43	334	352	300	-	6,32
550	IVERBR55	7 545,-	295,88	359	374	300	-	7,35	
600	IVERBR60	9 743,-	382,08	384	397	300	-	8,46	

Pozn.: Pro přetlak nutno použít těsnění U pod víčko

Těsnění U pro revizní koleno 85°	Ød	Kód	Cena [Kč / ks]	Cena [€ / ks]	A (mm)	B (mm)	C (mm)	D (mm)	Hmotnost: [kg / ks]
	80	IVEMDU08	243,-	9,53	-	-	-	-	0,01
	100	IVEMDU10	256,-	10,04	-	-	-	-	0,01
	110	IVEMDU11	277,-	10,86	-	-	-	-	0,01
	120	IVEMDU12	277,-	10,86	-	-	-	-	0,01
	130	IVEMDU13	305,-	11,96	-	-	-	-	0,01
	150	IVEMDU15	360,-	14,12	-	-	-	-	0,01
	160	IVEMDU16	360,-	14,12	-	-	-	-	0,01
	180	IVEMDU18	360,-	14,12	-	-	-	-	0,01
	200	IVEMDU20	360,-	14,12	-	-	-	-	0,01
	230	IVEMDU23	387,-	15,18	-	-	-	-	0,01
	250	IVEMDU25	387,-	15,18	-	-	-	-	0,01
	300	IVEMDU30	387,-	15,18	-	-	-	-	0,01
	350	IVEMDU35	387,-	15,18	-	-	-	-	0,01
	400	IVEMDU40	519,-	20,35	-	-	-	-	0,02
	450	IVEMDU45	609,-	23,88	-	-	-	-	0,02
	500	IVEMDU50	698,-	27,37	-	-	-	-	0,03
550	IVEMDU55	698,-	27,37	-	-	-	-	0,03	
600	IVEMDU60	698,-	27,37	-	-	-	-	0,03	

**Pozn.:**

Zvýrazněné položky v tabulkách jsou skladem. Ostatní s dodací lhůtou do 15 pracovních dnů.

Odváděč kondenzátu univerzální	Ød	Kód	Cena [Kč / ks]	Cena [€ / ks]	A (mm)	B (mm)	C (mm)	D (mm)	Hmotnost: [kg / ks]
	80	IVEKFU08	1 130,-	44,31	-	-	-	-	0,40
	100	IVEKFU10	1 170,-	45,88	-	-	-	-	0,40
	110	IVEKFU11	1 190,-	46,67	-	-	-	-	0,40
	120	IVEKFU12	1 210,-	47,45	-	-	-	-	0,50
	130	IVEKFU13	1 342,-	52,63	-	-	-	-	0,50
	150	IVEKFU15	1 461,-	57,29	-	-	-	-	0,60
	160	IVEKFU16	1 481,-	58,08	-	-	-	-	0,60
	180	IVEKFU18	1 626,-	63,76	-	-	-	-	0,70
	200	IVEKFU20	1 679,-	65,84	-	-	-	-	0,80
	230	IVEKFU23	1 738,-	68,16	-	-	-	-	1,10
	250	IVEKFU25	2 452,-	96,16	-	-	-	-	1,20
	300	IVEKFU30	2 941,-	115,33	-	-	-	-	2,33
	350	IVEKFU35	3 469,-	136,04	-	-	-	-	2,85
	400	IVEKFU40	4 492,-	176,16	-	-	-	-	3,40
	450	IVEKFU45	5 120,-	200,78	-	-	-	-	3,99
	500	IVEKFU50	5 780,-	226,67	-	-	-	-	4,63
	550	IVEKFU55	6 480,-	254,12	-	-	-	-	5,31
600	IVEKFU60	10 385,-	407,25	-	-	-	-	6,03	

Měřicí díl	Ød	Kód	Cena [Kč / ks]	Cena [€ / ks]	A (mm)	B (mm)	C (mm)	D (mm)	Hmotnost: [kg / ks]
	80	IVEMSU08	1 349,-	52,90	-	-	-	-	0,44
	100	IVEMSU10	1 383,-	54,24	-	-	-	-	0,50
	110	IVEMSU11	1 389,-	54,47	-	-	-	-	0,54
	120	IVEMSU12	1 408,-	55,22	-	-	-	-	0,57
	130	IVEMSU13	1 422,-	55,76	-	-	-	-	0,60
	150	IVEMSU15	1 435,-	56,27	-	-	-	-	0,65
	160	IVEMSU16	1 454,-	57,02	-	-	-	-	0,68
	180	IVEMSU18	1 488,-	58,35	-	-	-	-	0,75
	200	IVEMSU20	1 515,-	59,41	-	-	-	-	0,81
	230	IVEMSU23	1 547,-	60,67	-	-	-	-	1,05
	250	IVEMSU25	1 586,-	62,20	-	-	-	-	1,12
	300	IVEMSU30	1 706,-	66,90	-	-	-	-	1,31
	350	IVEMSU35	1 831,-	71,80	-	-	-	-	1,50
	400	IVEMSU40	1 996,-	78,27	-	-	-	-	1,69
	450	IVEMSU45	2 115,-	82,94	-	-	-	-	1,88
	500	IVEMSU50	2 220,-	87,06	-	-	-	-	2,06
	550	IVEMSU55	2 327,-	91,25	-	-	-	-	2,25
600	IVEMSU60	3 416,-	133,96	-	-	-	-	2,44	

Distanční objímka	Ød	Kód	Cena [Kč / ks]	Cena [€ / ks]	A (mm)	B (mm)	C (mm)	D (mm)	Hmotnost: [kg / ks]
	80	IVEFRU08	497,-	19,49	-	-	-	-	0,17
	100	IVEFRU10	497,-	19,49	-	-	-	-	0,20
	110	IVEFRU11	503,-	19,73	-	-	-	-	0,20
	120	IVEFRU12	503,-	19,73	-	-	-	-	0,20
	130	IVEFRU13	503,-	19,73	-	-	-	-	0,30
	150	IVEFRU15	510,-	20,00	-	-	-	-	0,30
	160	IVEFRU16	510,-	20,00	-	-	-	-	0,30
	180	IVEFRU18	516,-	20,24	-	-	-	-	0,30
	200	IVEFRU20	516,-	20,24	-	-	-	-	0,30
	230	IVEFRU23	524,-	20,55	-	-	-	-	0,30
	250	IVEFRU25	524,-	20,55	-	-	-	-	0,30
	300	IVEFRU30	536,-	21,02	-	-	-	-	0,30
	350	IVEFRU35	543,-	21,29	-	-	-	-	0,30
	400	IVEFRU40	557,-	21,84	-	-	-	-	0,30
	450	IVEFRU45	568,-	22,27	-	-	-	-	0,30
	500	IVEFRU50	577,-	22,63	-	-	-	-	0,30
	550	IVEFRU55	589,-	23,10	-	-	-	-	0,30
600	IVEFRU60	636,-	24,94	-	-	-	-	0,40	

**Pozn.:**

Zvýrazněné položky v tabulkách jsou skladem. Ostatní s dodací lhůtou do 15 pracovních dnů.

# JEDNOVRSTVÝ NEREZOVÝ SYSTÉM

## DN 80 – 600 mm

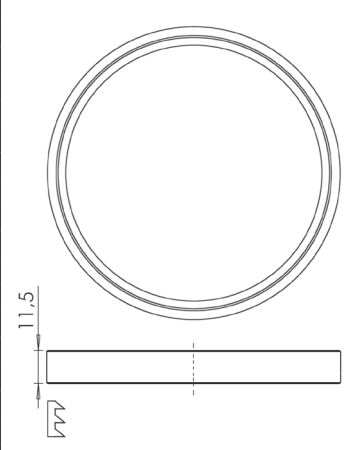
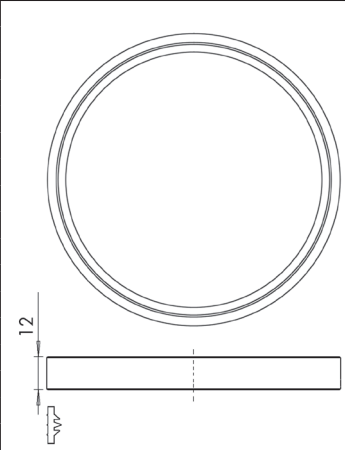
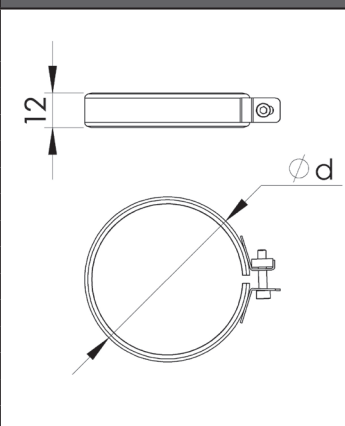
Těsnění Silikon (do 200°C)	Ød	Kód	Cena [Kč / ks]	Cena [€ / ks]	A (mm)	B (mm)	C (mm)	D (mm)	Hmotnost: [kg / ks]
	80	IVEMDE08	110,-	4,31	-	-	-	-	0,01
	100	IVEMDE10	132,-	5,18	-	-	-	-	0,01
	110	IVEMDE11	146,-	5,73	-	-	-	-	0,01
	120	IVEMDE12	167,-	6,55	-	-	-	-	0,01
	130	IVEMDE13	189,-	7,41	-	-	-	-	0,02
	150	IVEMDE15	197,-	7,73	-	-	-	-	0,02
	160	IVEMDE16	203,-	7,96	-	-	-	-	0,02
	180	IVEMDE18	225,-	8,82	-	-	-	-	0,02
	200	IVEMDE20	233,-	9,14	-	-	-	-	0,02
	230	IVEMDE23	262,-	10,27	-	-	-	-	0,03
	250	IVEMDE25	284,-	11,14	-	-	-	-	0,03
	300	IVEMDE30	342,-	13,41	-	-	-	-	0,04
	350	IVEMDE35	479,-	18,78	-	-	-	-	0,04
	400	IVEMDE40	523,-	20,51	-	-	-	-	0,05
450	IVEMDE45	559,-	21,92	-	-	-	-	0,05	
500	IVEMDE50	587,-	23,02	-	-	-	-	0,06	
550	IVEMDE55	632,-	24,78	-	-	-	-	0,06	
600	IVEMDE60	674,-	26,43	-	-	-	-	0,07	
Těsnění EPDM (do 120°C)	Ød	Kód	Cena [Kč / ks]	Cena [€ / ks]	A (mm)	B (mm)	C (mm)	D (mm)	Hmotnost: [kg / ks]
	80	IVEMDM08	83,-	3,25	-	-	-	-	0,01
	100	IVEMDM10	101,-	3,96	-	-	-	-	0,01
	-	-	-	-	-	-	-	-	-
	-	-	-	-	-	-	-	-	-
	130	IVEMDM13	152,-	5,96	-	-	-	-	0,02
	150	IVEMDM15	159,-	6,24	-	-	-	-	0,02
	160	IVEMDM16	164,-	6,43	-	-	-	-	0,02
	180	IVEMDM18	177,-	6,94	-	-	-	-	0,02
	200	IVEMDM20	184,-	7,22	-	-	-	-	0,02
	-	-	-	-	-	-	-	-	-
	250	IVEMDM25	227,-	8,90	-	-	-	-	0,03
	300	IVEMDM30	266,-	10,43	-	-	-	-	0,04
	350	IVEMDM35	373,-	14,63	-	-	-	-	0,04
	-	-	-	-	-	-	-	-	-
-	-	-	-	-	-	-	-	-	
-	-	-	-	-	-	-	-	-	
-	-	-	-	-	-	-	-	-	
-	-	-	-	-	-	-	-	-	
Spona EW	Ød	Kód	Cena [Kč / ks]	Cena [€ / ks]	A (mm)	B (mm)	C (mm)	D (mm)	Hmotnost: [kg / ks]
	80	IVEKLH08	120,-	4,71	-	-	-	-	0,04
	100	IVEKLH10	120,-	4,71	-	-	-	-	0,05
	110	IVEKLH11	120,-	4,71	-	-	-	-	0,05
	120	IVEKLH12	127,-	4,98	-	-	-	-	0,05
	130	IVEKLH13	127,-	4,98	-	-	-	-	0,05
	150	IVEKLH15	152,-	5,96	-	-	-	-	0,07
	160	IVEKLH16	152,-	5,96	-	-	-	-	0,07
	180	IVEKLH18	167,-	6,55	-	-	-	-	0,08
	200	IVEKLH20	172,-	6,75	-	-	-	-	0,08
	230	IVEKLH23	180,-	7,06	-	-	-	-	0,09
	250	IVEKLH25	187,-	7,33	-	-	-	-	0,10
	300	IVEKLH30	213,-	8,35	-	-	-	-	0,11
	350	IVEKLH35	239,-	9,37	-	-	-	-	0,15
	400	IVEKLH40	312,-	12,24	-	-	-	-	0,17
450	IVEKLH45	325,-	12,75	-	-	-	-	0,19	
500	IVEKLH50	337,-	13,22	-	-	-	-	0,22	

**Pozn.:**

Zvýrazněné položky v tabulkách jsou skladem. Ostatní s dodací lhůtou do 15 pracovních dnů.

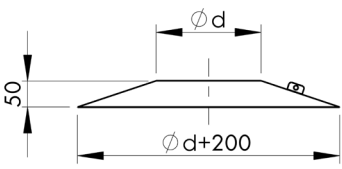
Rozeta a manžeta proti zatékání	Ød	Kód	Cena [Kč / ks]	Cena [€ / ks]	A (mm)	B (mm)	C (mm)	D (mm)	Hmotnost: [kg / ks]
	80	IVEWBU08	384,-	15,06	-	-	-	-	0,42
	100	IVEWBU10	411,-	16,12	-	-	-	-	0,48
	110	IVEWBU11	431,-	16,90	-	-	-	-	0,51
	120	IVEWBU12	445,-	17,45	-	-	-	-	0,54
	130	IVEWBU13	464,-	18,20	-	-	-	-	0,57
	150	IVEWBU15	490,-	19,22	-	-	-	-	0,64
	160	IVEWBU16	503,-	19,73	-	-	-	-	0,68
	180	IVEWBU18	530,-	20,78	-	-	-	-	0,74
	200	IVEWBU20	568,-	22,27	-	-	-	-	0,82
	230	IVEWBU23	629,-	24,67	-	-	-	-	0,94
	250	IVEWBU25	668,-	26,20	-	-	-	-	1,04
	300	IVEWBU30	774,-	30,35	-	-	-	-	1,27
	350	IVEWBU35	880,-	34,51	-	-	-	-	1,53
	400	IVEWBU40	1 210,-	47,45	-	-	-	-	2,17
	450	IVEWBU45	1 369,-	53,69	-	-	-	-	2,54
	500	IVEWBU50	1 547,-	60,67	-	-	-	-	2,94
	550	IVEWBU55	1 732,-	67,92	-	-	-	-	3,37
600	IVEWBU60	1 931,-	75,73	-	-	-	-	3,82	

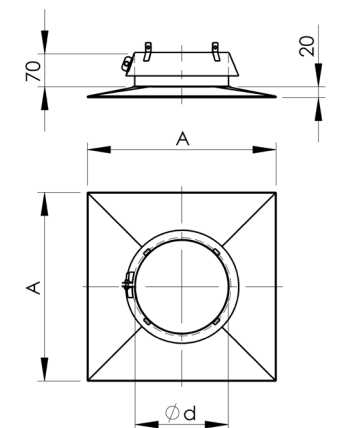
Krycí deska s manžetou proti zatékání	Ød	Kód	Cena [Kč / ks]	Cena [€ / ks]	A x A (mm)	B (mm)	C (mm)	D (mm)	Hmotnost: [kg / ks]
	80	IVEKPU08	1 105,-	43,33	340x340	-	-	-	0,80
	100	IVEKPU10	1 105,-	43,33	340x340	-	-	-	0,90
	110	IVEKPU11	1 151,-	45,14	340x340	-	-	-	0,90
	120	IVEKPU12	1 151,-	45,14	340x340	-	-	-	1,00
	130	IVEKPU13	1 185,-	46,47	340x340	-	-	-	1,00
	150	IVEKPU15	1 374,-	53,88	400x400	-	-	-	1,30
	160	IVEKPU16	1 408,-	55,22	400x400	-	-	-	1,30
	180	IVEKPU18	1 474,-	57,80	400x400	-	-	-	1,40
	200	IVEKPU20	1 554,-	60,94	400x400	-	-	-	1,50
	230	IVEKPU23	1 679,-	65,84	400x400	-	-	-	1,90
	250	IVEKPU25	1 765,-	69,22	400x400	-	-	-	2,10
	300	IVEKPU30	2 220,-	87,06	500x500	-	-	-	3,00
	350	IVEKPU35	2 385,-	93,53	550x550	-	-	-	3,40
	400	IVEKPU40	2 874,-	112,71	600x600	-	-	-	4,10
	450	IVEKPU45	3 331,-	130,63	650x650	-	-	-	4,80
	500	IVEKPU50	3 760,-	147,45	700x700	-	-	-	5,80
	550	IVEKPU55	4 355,-	170,78	750x750	-	-	-	6,70
600	IVEKPU60	6 824,-	267,61	800x800	-	-	-	7,60	

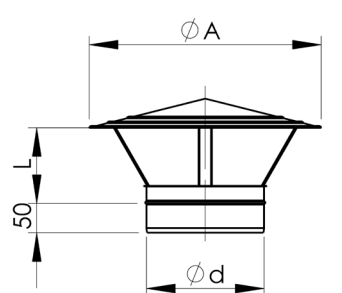
Meidingerova hlava	Ød	Kód	Cena [Kč / ks]	Cena [€ / ks]	A (mm)	L (mm)	C (mm)	D (mm)	Hmotnost: [kg / ks]
	80	IVERHU08	582,-	22,82	155	50	-	-	0,26
	100	IVERHU10	636,-	24,94	195	60	-	-	0,34
	110	IVERHU11	662,-	25,96	215	70	-	-	0,39
	120	IVERHU12	675,-	26,47	235	70	-	-	0,43
	130	IVERHU13	714,-	28,00	255	80	-	-	0,48
	150	IVERHU15	808,-	31,69	295	100	-	-	0,63
	160	IVERHU16	846,-	33,18	310	100	-	-	0,69
	180	IVERHU18	940,-	36,86	350	110	-	-	0,82
	200	IVERHU20	1 025,-	40,20	390	120	-	-	0,97
	230	IVERHU23	1 316,-	51,61	450	150	-	-	1,49
	250	IVERHU25	1 448,-	56,78	490	150	-	-	1,70
	300	IVERHU30	1 878,-	73,65	585	200	-	-	2,40
	350	IVERHU35	2 464,-	96,63	680	230	-	-	3,15
	400	IVERHU40	3 040,-	119,22	780	250	-	-	4,00
	450	IVERHU45	3 607,-	141,45	875	300	-	-	4,94
	500	IVERHU50	4 268,-	167,37	970	330	-	-	5,98
	550	IVERHU55	4 935,-	193,53	1070	350	-	-	6,60
600	IVERHU60	7 777,-	304,98	1170	400	-	-	11,13	

**Pozn.:**

Zvýrazněné položky v tabulkách jsou skladem. Ostatní s dodací lhůtou do 15 pracovních dnů.



# JEDNOVRSTVÝ NEREZOVÝ SYSTÉM

## DN 80 – 600 mm

Lapač jisker	Ød	Kód	Cena [Kč / ks]	Cena [€ / ks]	ØA (mm)	L (mm)	C (mm)	D (mm)	Hmotnost: [kg / ks]
	80	IVEFGU08	1 084,-	42,51	155	50	-	-	0,25
	100	IVEFGU10	1 233,-	48,35	195	60	-	-	0,35
	110	IVEFGU11	1 354,-	53,10	215	70	-	-	0,41
	120	IVEFGU12	1 366,-	53,57	235	70	-	-	0,46
	130	IVEFGU13	1 471,-	57,69	255	80	-	-	0,52
	150	IVEFGU15	1 677,-	65,76	295	100	-	-	0,65
	160	IVEFGU16	1 759,-	68,98	310	100	-	-	0,72
	180	IVEFGU18	1 946,-	76,31	350	110	-	-	0,87
	200	IVEFGU20	2 157,-	84,59	390	120	-	-	1,04
	230	IVEFGU23	2 781,-	109,06	450	150	-	-	1,57
	250	IVEFGU25	2 979,-	116,82	490	150	-	-	1,80
	300	IVEFGU30	3 989,-	156,43	585	200	-	-	2,49
	350	IVEFGU35	5 013,-	196,59	680	230	-	-	3,28
	400	IVEFGU40	6 982,-	273,80	780	250	-	-	4,13
	450	IVEFGU45	8 647,-	339,10	875	300	-	-	5,08
	500	IVEFGU50	9 900,-	388,24	970	330	-	-	6,39
	550	IVEFGU55	11 275,-	442,16	1070	350	-	-	7,26
	600	IVEFGU60	15 536,-	609,25	1170	400	-	-	11,15

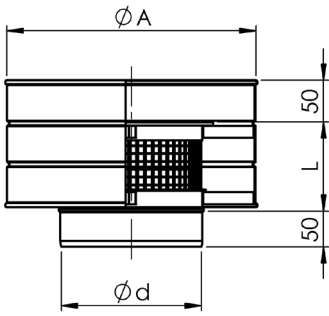

Klapka (podtlak)	Ød	Kód	Cena [Kč / ks]	Cena [€ / ks]	L (mm)	B (mm)	C (mm)	D (mm)	Hmotnost: [kg / ks]
	80	IVEHRK08	1 996,-	78,27	150	-	-	-	0,52
	100	IVEHRK10	2 048,-	80,31	150	-	-	-	0,62
	110	IVEHRK11	2 115,-	82,94	150	-	-	-	0,72
	120	IVEHRK12	2 128,-	83,45	170	-	-	-	0,78
	130	IVEHRK13	2 161,-	84,75	170	-	-	-	0,84
	150	IVEHRK15	2 233,-	87,57	170	-	-	-	0,98
	160	IVEHRK16	2 280,-	89,41	180	-	-	-	1,08
	180	IVEHRK18	2 399,-	94,08	200	-	-	-	1,29
	200	IVEHRK20	2 517,-	98,71	220	-	-	-	1,53
	230	IVEHRK23	2 828,-	110,90	250	-	-	-	1,92
	250	IVEHRK25	2 980,-	116,86	270	-	-	-	2,21
	300	IVEHRK30	4 111,-	161,22	320	-	-	-	3,03
	350	IVEHRK35	4 572,-	179,29	370	-	-	-	4,01
	400	IVEHRK40	5 298,-	207,76	420	-	-	-	4,79
	450	IVEHRK45	6 191,-	242,78	470	-	-	-	6,33
	500	IVEHRK50	7 002,-	274,59	520	-	-	-	7,70
	550	IVEHRK55	7 822,-	306,75	570	-	-	-	9,21
	600	IVEHRK60	10 086,-	395,53	620	-	-	-	10,86

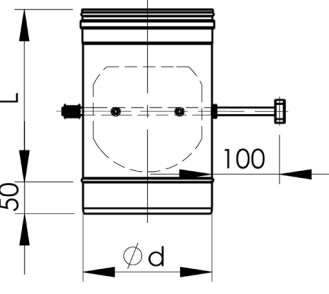

Explozní klapka	Ød	Kód	Cena [Kč / ks]	Cena [€ / ks]	H (mm)	W (mm)	C (mm)	D (mm)	Hmotnost: [kg / ks]
	-	-	-	-	-	-	-	-	-
	-	-	-	-	-	-	-	-	-
	-	-	-	-	-	-	-	-	-
	-	-	-	-	-	-	-	-	-
	-	-	-	-	-	-	-	-	-
	-	-	-	-	-	-	-	-	-
	-	-	-	-	-	-	-	-	-
	-	-	-	-	-	-	-	-	-
	-	-	-	-	-	-	-	-	-
	-	-	-	-	-	-	-	-	-
	-	-	-	-	-	-	-	-	-
	-	-	-	-	-	-	-	-	-
	-	-	-	-	-	-	-	-	-
	-	-	-	-	-	-	-	-	-
	-	-	-	-	-	-	-	-	-
	250	IVEEDU25	8 296,-	325,33	-	-	-	-	-
	300	IVEEDU30	9 567,-	375,18	-	-	-	-	-
	350	IVEEDU35	10 964,-	429,96	-	-	-	-	-
	400	IVEEDU40	12 563,-	492,67	-	-	-	-	-
	450	IVEEDU45	14 527,-	569,69	-	-	-	-	-
	500	IVEEDU50	16 383,-	642,47	-	-	-	-	-
	-	-	-	-	-	-	-	-	-
	-	-	-	-	-	-	-	-	-

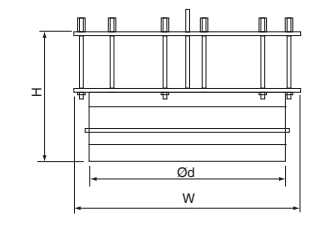

**Pozn.:**  
Zvýrazněné položky v tabulkách jsou skladem. Ostatní s dodací lhůtou do 15 pracovních dnů.

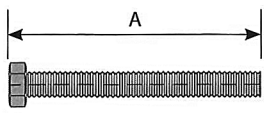
Hadice na odvod kondenzátu	Ød	Kód	Cena [Kč / ks]	Cena [€ / ks]	A (mm)	B (mm)	C (mm)	D (mm)	Hmotnost: [kg / ks]
	80	IVEWKU03	345,-	13,53	300	-	-	-	-
	100	IVEWKU03	345,-	13,53	300	-	-	-	-
	113	IVEWKU03	345,-	13,53	300	-	-	-	-
	120	IVEWKU03	345,-	13,53	300	-	-	-	-
	130	IVEWKU03	345,-	13,53	300	-	-	-	-
	140	IVEWKU03	345,-	13,53	300	-	-	-	-
	150	IVEWKU03	345,-	13,53	300	-	-	-	-
	160	IVEWKU03	345,-	13,53	300	-	-	-	-
	180	IVEWKU03	345,-	13,53	300	-	-	-	-
	200	IVEWKU03	345,-	13,53	300	-	-	-	-
	230	IVEWKU03	345,-	13,53	300	-	-	-	-
	250	IVEWKU03	345,-	13,53	300	-	-	-	-
	300	IVEWKU03	345,-	13,53	300	-	-	-	-
	350	IVEWKU03	345,-	13,53	300	-	-	-	-

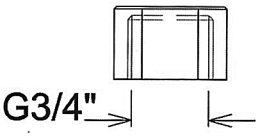
Matka mosazná	Ød	Kód	Cena [Kč / ks]	Cena [€ / ks]	A (mm)	B (mm)	C (mm)	D (mm)	Hmotnost: [kg / ks]
	80	IVEBNU00	61,-	2,39	-	-	-	-	-
	100	IVEBNU00	61,-	2,39	-	-	-	-	-
	113	IVEBNU00	61,-	2,39	-	-	-	-	-
	120	IVEBNU00	61,-	2,39	-	-	-	-	-
	130	IVEBNU00	61,-	2,39	-	-	-	-	-
	140	IVEBNU00	61,-	2,39	-	-	-	-	-
	150	IVEBNU00	61,-	2,39	-	-	-	-	-
	160	IVEBNU00	61,-	2,39	-	-	-	-	-
	180	IVEBNU00	61,-	2,39	-	-	-	-	-
	200	IVEBNU00	61,-	2,39	-	-	-	-	-
	230	IVEBNU00	61,-	2,39	-	-	-	-	-
	250	IVEBNU00	61,-	2,39	-	-	-	-	-
	300	IVEBNU00	61,-	2,39	-	-	-	-	-
	350	IVEBNU00	61,-	2,39	-	-	-	-	-

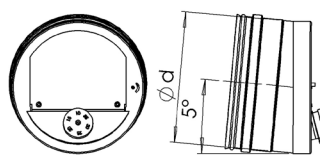
Regulátor tahu (podtlak)	Ød	Kód	Cena [Kč / ks]	Cena [€ / ks]	A (mm)	B (mm)	C (mm)	D (mm)	Hmotnost: [kg / ks]
	80	IVEZRU08	3 422,-	134,20	-	-	-	-	0,30
	150	IVEZRU15	3 792,-	148,71	-	-	-	-	0,42

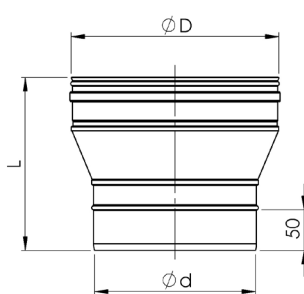
Centrická redukce	Ød	Kód	Cena [Kč / ks]	Cena [€ / ks]	ØA (mm)	L (mm)	C (mm)	D (mm)	Hmotnost: [kg / ks]
	80	-	-	-	-	200	-	-	-
	100	IVEKKxxxxxx	557,-	21,84	-	200	-	-	-
	110	IVEKKxxxxxx	568,-	22,27	-	200	-	-	-
	120	IVEKKxxxxxx	577,-	22,63	-	200	-	-	-
	130	IVEKKxxxxxx	582,-	22,82	-	200	-	-	-
	150	IVEKKxxxxxx	662,-	25,96	-	200	-	-	-
	160	IVEKKxxxxxx	808,-	31,69	-	200	-	-	-
	180	IVEKKxxxxxx	986,-	38,67	-	200	-	-	-
	200	IVEKKxxxxxx	1 090,-	42,75	-	200	-	-	-
	230	IVEKKxxxxxx	1 251,-	49,06	-	200	-	-	-
	250	IVEKKxxxxxx	1 362,-	53,41	-	200	-	-	-
	300	IVEKKxxxxxx	1 435,-	56,27	-	200	-	-	-
	350	IVEKKxxxxxx	1 772,-	69,49	-	200	-	-	-
	400	IVEKKxxxxxx	2 121,-	83,18	-	200	-	-	-
	450	IVEKKxxxxxx	2 418,-	94,82	-	200	-	-	-
	500	IVEKKxxxxxx	3 244,-	127,22	-	200	-	-	-
550	IVEKKxxxxxx	4 440,-	174,12	-	200	-	-	-	
600	IVEKKxxxxxx	5 034,-	197,41	-	200	-	-	-	

**Pozn.:**

Zvýrazněné položky v tabulkách jsou skladem. Ostatní s dodací lhůtou do 15 pracovních dnů.

Excentrická redukce	Ød	Kód	Cena [Kč / ks]	Cena [€ / ks]	ØA (mm)	L (mm)	C (mm)	D (mm)	Hmotnost: [kg / ks]
	80	-	-	-	-	200	-	-	-
	100	IVEKXxxxxxx	689,-	27,02	-	200	-	-	-
	110	IVEKXxxxxxx	728,-	28,55	-	200	-	-	-
	120	IVEKXxxxxxx	754,-	29,57	-	200	-	-	-
	130	IVEKXxxxxxx	780,-	30,59	-	200	-	-	-
	150	IVEKXxxxxxx	808,-	31,69	-	200	-	-	-
	160	IVEKXxxxxxx	834,-	32,71	-	200	-	-	-
	180	IVEKXxxxxxx	1 105,-	43,33	-	200	-	-	-
	200	IVEKXxxxxxx	1 230,-	48,24	-	200	-	-	-
	230	IVEKXxxxxxx	1 415,-	55,49	-	200	-	-	-
	250	IVEKXxxxxxx	1 580,-	61,96	-	200	-	-	-
	300	IVEKXxxxxxx	1 838,-	72,08	-	200	-	-	-
	350	IVEKXxxxxxx	2 148,-	84,24	-	200	-	-	-
	400	IVEKXxxxxxx	2 874,-	112,71	-	200	-	-	-
	450	IVEKXxxxxxx	3 390,-	132,94	-	200	-	-	-
	500	IVEKXxxxxxx	3 950,-	154,90	-	200	-	-	-
550	IVEKXxxxxxx	4 465,-	175,10	-	200	-	-	-	
600	IVEKXxxxxxx	5 054,-	198,20	-	200	-	-	-	

Objednávání redukci:	Příklad objednávání redukci:									
<p> <b>► směr spalin</b>  <b>◄ směr kondenzátu</b> </p> <p>Cenu redukce určuje to DN, které je na redukci větší.                      Rozměr <math>\varnothing d</math> je vždy vnější, rozměr <math>\varnothing D</math> je vždy vnitřní.                      Do objednáčích znaků redukce zadejte zleva do prava:  <math>\varnothing d</math> a <math>\varnothing D</math> v milimetrech.  <b><math>\varnothing d</math> = signa, hrdlo spotřebiče (kotel)</b>  <b><math>\varnothing D</math> = hrdlo, komínový systém</b></p> <table border="1"> <thead> <tr> <th>Typ redukce</th> <th>IVEKK xxxxxx</th> <th>IVEKX xxxxxx</th> </tr> </thead> <tbody> <tr> <td><math>\varnothing d</math> ( mm )</td> <td></td> <td></td> </tr> <tr> <td><math>\varnothing D</math> ( mm )</td> <td></td> <td></td> </tr> </tbody> </table>	Typ redukce	IVEKK xxxxxx	IVEKX xxxxxx	$\varnothing d$ ( mm )			$\varnothing D$ ( mm )			<p>Potřebuji v systému <b>EW</b> udělat kouřovod pro odvod spalin od kotlů zapojených do kaskády a potřebuji, aby se v kouřovodu nehromadil kondenzát.                      Dimenze se bude měnit z DN 200 mm na DN 250 mm.</p> <p><b>Řešení:</b>                      Zvolím „<b>Redukci v systému EW excentrickou</b>“                      S objednáčím znakem: <b>IVEKX200250</b>                      Cena redukce bude stanovena podle DN 250 mm.</p>
Typ redukce	IVEKK xxxxxx	IVEKX xxxxxx								
$\varnothing d$ ( mm )										
$\varnothing D$ ( mm )										

**Pozn.:**  
 Zvýrazněné položky v tabulkách jsou skladem. Ostatní s dodací lhůtou do 15 pracovních dnů.



## DW25

Univerzální třívrstvý nerezový komínový systém, odolný proti vlhkosti, pro podtlakový i přetlakový provoz.

### Tloušťka stěny:

0,5 mm DN ≤ 200 mm

0,6 mm DN ≥ 250 mm

### Tloušťka izolace:

25 mm

### Tloušťka pláště:

0,5 mm DN ≤ 300 mm

0,6 mm DN ≥ 350 mm

### Vlastnosti systému:

- široká oblast použití
- odolný proti vlhkosti
- při použití těsnění vhodný pro přetlakový provoz
- univerzální systém
- jednoduchý přechod na jednovrstvý systém
- vnitřní i vnější montáž
- volně stojící komíny
- systém obsahuje spony

Univerzální třívrstvý nerezový komínový systém **ALMEVA Triple DW25** je vhodný pro všechny typy paliv a všechny typy spotřebičů, které pracují jak v podtlakovém, tak i přetlakovém provozu.

Široká oblast použití: běžné tepelné spotřebiče, kondenzační spotřebiče, výtopy, generátory, blokové kotelny, nouzové agregáty, pece.

Kvalitní nerezová ocel třídy 1.4404 a kvalitní technické řešení umožňuje i tzv. mokrá provoz - systém je odolný vůči vlhkosti. Systém umožňuje jednoduchý přechod na jednovrstvé systémy.

#### Pozn.:

Zvýrazněné položky v tabulkách jsou skladem.

Ostatní s dodací lhůtou do 15 pracovních dnů.

#### Technická data pro **ALMEVA Triple DW25**:

**Třída nerezové oceli: 1.4404 / 316L**

**Zatřídění dle EN 1856 - 1:**

DW25	EN 1856-1 T600 N1 W V2 L50 (050, 060, 080) G
DW25	EN 1856-1 T450 N1 W V2 L50 (050, 060, 080) G
DW25	EN 1856-1 T200 P1 W V2 L50 (050, 060, 080) O (silikonové těsnění)
DW25	EN 1856-1 T120 P1 W V2 L50 (050, 060, 080) O (EPDM těsnění)

Dno s odvodem kondenz. - dolů	Ød	ØD	Kód	Cena [Kč / ks]	Cena [€ / ks]	A (mm)	B (mm)	C (mm)	D (mm)	Hmotnost: [kg / ks]
	80	130	IVDFAS08	1 765,-	69,22	-	-	-	-	1,56
	100	150	IVDFAS10	1 943,-	76,20	-	-	-	-	1,84
	130	180	IVDFAS13	2 068,-	81,10	-	-	-	-	2,28
	150	200	IVDFAS15	2 180,-	85,49	-	-	-	-	2,59
	180	230	IVDFAS18	2 347,-	92,04	-	-	-	-	3,09
	200	250	IVDFAS20	2 531,-	99,25	-	-	-	-	3,45
	250	300	IVDFAS25	3 429,-	134,47	-	-	-	-	5,30
	300	350	IVDFAS30	3 964,-	155,45	-	-	-	-	6,56
	350	400	IVDFAS35	5 101,-	200,04	-	-	-	-	9,13
	400	450	IVDFAS40	5 978,-	234,43	-	-	-	-	10,88
	450	500	IVDFAS45	7 756,-	304,16	-	-	-	-	13,30
	500	550	IVDFAS50	8 891,-	348,67	-	-	-	-	15,38
	550	600	IVDFAS55	9 526,-	373,57	-	-	-	-	17,60

Dno bez desky	Ød	ØD	Kód	Cena [Kč / ks]	Cena [€ / ks]	A (mm)	B (mm)	C (mm)	D (mm)	Hmotnost: [kg / ks]
	80	130	IVDMAS08	1 110,-	43,53	-	-	-	-	0,53
	100	150	IVDMAS10	1 210,-	47,45	-	-	-	-	0,63
	130	180	IVDMAS13	1 369,-	53,69	-	-	-	-	0,80
	150	200	IVDMAS15	1 488,-	58,35	-	-	-	-	0,91
	180	230	IVDMAS18	1 667,-	65,37	-	-	-	-	1,10
	200	250	IVDMAS20	1 799,-	70,55	-	-	-	-	1,23
	250	300	IVDMAS25	2 399,-	94,08	-	-	-	-	1,68
	300	350	IVDMAS30	3 126,-	122,59	-	-	-	-	2,27
	350	400	IVDMAS35	3 700,-	145,10	-	-	-	-	2,78
	400	450	IVDMAS40	4 532,-	177,73	-	-	-	-	3,34
	450	500	IVDMAS45	5 126,-	201,02	-	-	-	-	3,94
	500	550	IVDMAS50	5 761,-	225,92	-	-	-	-	4,59
	550	600	IVDMAS55	6 435,-	252,35	-	-	-	-	5,29

Dno s odvodem kondenz. - do boku	Ød	ØD	Kód	Cena [Kč / ks]	Cena [€ / ks]	A (mm)	B (mm)	C (mm)	D (mm)	Hmotnost: [kg / ks]
	80	130	IVDMAW08	1 732,-	67,92	-	230	-	-	0,80
	100	150	IVDMAW10	1 851,-	72,59	-	250	-	-	0,90
	130	180	IVDMAW13	1 970,-	77,25	-	280	-	-	1,10
	150	200	IVDMAW15	2 220,-	87,06	-	300	-	-	1,30
	180	230	IVDMAW18	2 332,-	91,45	-	330	-	-	1,50
	200	250	IVDMAW20	2 577,-	101,06	-	350	-	-	1,70
	250	300	IVDMAW25	2 980,-	116,86	-	400	-	-	2,50
	300	350	IVDMAW30	3 508,-	137,57	-	450	-	-	3,30
	350	400	IVDMAW35	4 280,-	167,84	-	500	-	-	4,00
	400	450	IVDMAW40	6 116,-	239,84	-	550	-	-	4,80
	450	500	IVDMAW45	6 904,-	270,75	-	600	-	-	5,50
	500	550	IVDMAW50	7 530,-	295,29	-	650	-	-	6,40
	550	600	IVDMAW55	8 119,-	318,39	-	700	-	-	7,40

Vynášecí díl	Ød	ØD	Kód	Cena [Kč / ks]	Cena [€ / ks]	A (mm)	B (mm)	C (mm)	D (mm)	Hmotnost: [kg / ks]
	80	130	IVDZSU08	2 010,-	78,82	160	230	-	-	1,08
	100	150	IVDZSU10	2 102,-	82,43	160	250	-	-	1,22
	130	180	IVDZSU13	2 385,-	93,53	160	280	-	-	1,46
	150	200	IVDZSU15	2 517,-	98,71	160	300	-	-	1,71
	180	230	IVDZSU18	2 822,-	110,67	160	330	-	-	1,99
	200	250	IVDZSU20	3 012,-	118,12	160	350	-	-	2,19
	250	300	IVDZSU25	3 760,-	147,45	160	400	-	-	3,20
	300	350	IVDZSU30	5 101,-	200,04	160	450	-	-	6,24
	350	400	IVDZSU35	6 375,-	250,00	160	500	-	-	7,77
	400	450	IVDZSU40	7 378,-	289,33	160	550	-	-	12,02
	450	500	IVDZSU45	9 228,-	361,88	160	600	-	-	13,94
	500	550	IVDZSU50	9 842,-	385,96	160	650	-	-	16,00
	550	600	IVDZSU55	11 248,-	441,10	160	700	-	-	18,20

**Pozn.:**

Zvýrazněné položky v tabulkách jsou skladem. Ostatní s dodací lhůtou do 15 pracovních dnů.

Dvířkový díl s vnitřními dvířky (podtlak)	Ød	ØD	Kód	Cena [Kč / ks]	Cena [€ / ks]	L (mm)	B (mm)	C (mm)	D (mm)	Hmotnost: [kg / ks]
	80	130	-	-	-	-	-	-	-	-
	100	150	-	-	-	-	-	-	-	-
	130	180	IVDFT913	4 917,-	192,82	380	-	-	-	4,91
	150	200	IVDFT915	5 028,-	197,18	380	-	-	-	5,28
	180	230	IVDFT918	5 198,-	203,84	380	-	-	-	5,81
	200	250	IVDFT920	5 324,-	208,78	380	-	-	-	6,19
	250	300	IVDFT925	5 827,-	228,51	380	-	-	-	7,47
	300	350	IVDFT930	6 402,-	251,06	380	-	-	-	8,81
	350	400	IVDFT935	7 393,-	289,92	380	-	-	-	9,84
	400	450	IVDFT940	9 168,-	359,53	380	-	-	-	10,89
	450	500	IVDFT945	10 331,-	405,14	380	-	-	-	11,95
	500	550	IVDFT950	10 892,-	427,14	380	-	-	-	13,00
550	600	IVDFT955	11 394,-	446,82	380	-	-	-	14,05	

Kontrolní díl	Ød	ØD	Kód	Cena [Kč / ks]	Cena [€ / ks]	L (mm)	X (mm)	C (mm)	D (mm)	Hmotnost: [kg / ks]
	80	130	IVDRTN08	3 158,-	123,84	350	179	-	-	2,79
	100	150	IVDRTN10	3 323,-	130,31	370	188	-	-	3,41
	130	180	IVDRTN13	3 700,-	145,10	400	202	-	-	4,39
	150	200	IVDRTN15	3 918,-	153,65	420	211	-	-	5,09
	180	230	IVDRTN18	4 519,-	177,22	450	225	-	-	6,21
	200	250	IVDRTN20	5 186,-	203,37	470	234	-	-	7,02
	250	300	IVDRTN25	6 144,-	240,94	520	257	-	-	9,46
	300	350	IVDRTN30	8 535,-	334,71	570	280	-	-	12,76
	350	400	IVDRTN35	10 377,-	406,94	620	303	-	-	15,62
	400	450	IVDRTN40	13 051,-	511,80	670	325	-	-	20,20
	450	500	IVDRTN45	15 040,-	589,80	720	348	-	-	23,72
	500	550	IVDRTN50	17 153,-	672,67	770	371	-	-	27,49
550	600	IVDRTN55	20 297,-	795,96	820	394	-	-	31,50	

Pozn.: Pro přetlak nutno použít těsnění Silikon nebo EPDM pro víčko

Sopouch 90°	Ød	ØD	Kód	Cena [Kč / ks]	Cena [€ / ks]	L (mm)	Z (mm)	X (mm)	D (mm)	Hmotnost: [kg / ks]
	-	-	-	-	-	-	-	-	-	-
	-	-	-	-	-	-	-	-	-	-
	-	-	-	-	-	-	-	-	-	-
	150	200	IVDTE915	3 265,-	128,04	420	175	211	-	3,76
	180	230	IVDTE918	3 806,-	149,25	450	190	225	-	4,62
	200	250	IVDTE920	4 189,-	164,27	470	200	234	-	5,22
	-	-	-	-	-	-	-	-	-	-
	-	-	-	-	-	-	-	-	-	-
	-	-	-	-	-	-	-	-	-	-
	-	-	-	-	-	-	-	-	-	-
	-	-	-	-	-	-	-	-	-	-
	-	-	-	-	-	-	-	-	-	-

Sopouch 85°	Ød	ØD	Kód	Cena [Kč / ks]	Cena [€ / ks]	L (mm)	Z (mm)	X (mm)	D (mm)	Hmotnost: [kg / ks]
	80	130	IVDTE808	2 320,-	90,98	350	141	179	-	2,01
	100	150	IVDTE810	2 630,-	103,14	370	152	188	-	2,47
	130	180	IVDTE813	2 927,-	114,78	400	168	202	-	3,22
	150	200	IVDTE815	3 265,-	128,04	420	179	211	-	3,76
	180	230	IVDTE818	3 806,-	149,25	450	196	225	-	4,62
	200	250	IVDTE820	4 189,-	164,27	470	207	234	-	5,22
	250	300	IVDTE825	6 216,-	243,76	520	234	257	-	7,27
	300	350	IVDTE830	7 894,-	309,57	570	261	280	-	9,80
	350	400	IVDTE835	11 044,-	433,10	620	288	303	-	12,06
	400	450	IVDTE840	14 228,-	557,96	670	396	325	-	16,01
	450	500	IVDTE845	16 494,-	646,82	720	423	348	-	18,84
	500	550	IVDTE850	18 876,-	740,24	770	450	371	-	21,88
550	600	IVDTE855	21 428,-	840,31	820	478	394	-	25,11	

**Pozn.:** Zvýrazněné položky v tabulkách jsou skladem. Ostatní s dodací lhůtou do 15 pracovních dnů.

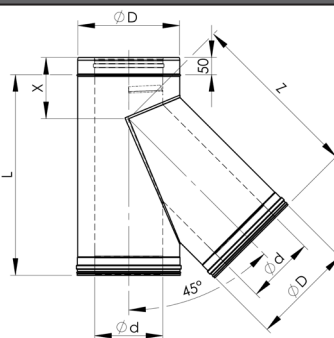
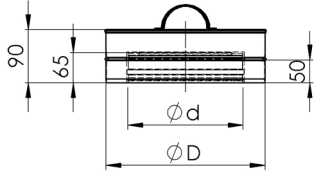
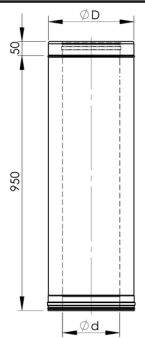
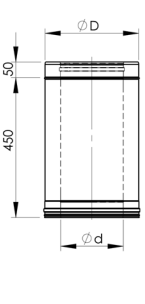
Sopouch 45°	Ød	ØD	Kód	Cena [Kč / ks]	Cena [€ / ks]	L (mm)	Z (mm)	X (mm)	D (mm)	Hmotnost: [kg / ks]
	80	130	IVDTE408	4 539,-	178,00	402	306	147	-	2,78
	100	150	IVDTE410	4 796,-	188,08	430	330	151	-	3,47
	130	180	IVDTE413	4 942,-	193,80	472	366	157	-	4,61
	150	200	IVDTE415	5 153,-	202,08	500	390	161	-	5,43
	180	230	IVDTE418	6 402,-	251,06	542	426	167	-	6,77
	200	250	IVDTE420	6 500,-	254,90	570	450	171	-	7,73
	250	300	IVDTE425	8 058,-	316,00	640	510	181	-	10,97
	300	350	IVDTE430	9 962,-	390,67	710	570	191	-	15,04
	350	400	IVDTE435	12 371,-	485,14	780	630	201	-	18,77
	400	450	IVDTE440	19 003,-	745,22	850	690	211	-	23,13
	450	500	IVDTE445	22 286,-	873,96	920	750	221	-	27,67
	500	550	IVDTE450	25 837,-	1013,22	990	810	231	-	32,60
550	600	IVDTE455	29 635,-	1162,16	1060	870	241	-	37,92	
Uzávěr na sopouch	Ød	ØD	Kód	Cena [Kč / ks]	Cena [€ / ks]	A (mm)	B (mm)	C (mm)	D (mm)	Hmotnost: [kg / ks]
	80	130	IVDENU08	893,-	35,02	-	-	-	-	0,53
	100	150	IVDENU10	958,-	37,57	-	-	-	-	0,63
	130	180	IVDENU13	1 071,-	42,00	-	-	-	-	0,80
	150	200	IVDENU15	1 151,-	45,14	-	-	-	-	0,91
	180	230	IVDENU18	1 277,-	50,08	-	-	-	-	1,10
	200	250	IVDENU20	1 374,-	53,88	-	-	-	-	1,23
	250	300	IVDENU25	1 586,-	62,20	-	-	-	-	1,68
	300	350	IVDENU30	2 075,-	81,37	-	-	-	-	2,27
	350	400	IVDENU35	2 444,-	95,84	-	-	-	-	2,78
	400	450	IVDENU40	2 980,-	116,86	-	-	-	-	3,34
	450	500	IVDENU45	3 376,-	132,39	-	-	-	-	3,94
	500	550	IVDENU50	3 779,-	148,20	-	-	-	-	4,59
550	600	IVDENU55	4 208,-	165,02	-	-	-	-	5,29	
Rovný díl 950mm	Ød	ØD	Kód	Cena [Kč / ks]	Cena [€ / ks]	A (mm)	B (mm)	C (mm)	D (mm)	Hmotnost: [kg / ks]
	80	130	IVDRM108	1 884,-	73,88	-	-	-	-	4,11
	100	150	IVDRM110	2 154,-	84,47	-	-	-	-	4,89
	130	180	IVDRM113	2 439,-	95,65	-	-	-	-	6,06
	150	200	IVDRM115	2 716,-	106,51	-	-	-	-	6,84
	180	230	IVDRM118	3 066,-	120,24	-	-	-	-	8,00
	200	250	IVDRM120	3 297,-	129,29	-	-	-	-	8,78
	250	300	IVDRM125	3 978,-	156,00	-	-	-	-	11,35
	300	350	IVDRM130	5 067,-	198,71	-	-	-	-	14,30
	350	400	IVDRM135	5 946,-	233,18	-	-	-	-	16,49
	400	450	IVDRM140	7 161,-	280,82	-	-	-	-	18,69
	450	500	IVDRM145	7 934,-	311,14	-	-	-	-	20,88
	500	550	IVDRM150	8 501,-	333,37	-	-	-	-	23,08
550	600	IVDRM155	9 102,-	356,94	-	-	-	-	25,27	
Rovný díl 450mm	Ød	ØD	Kód	Cena [Kč / ks]	Cena [€ / ks]	A (mm)	B (mm)	C (mm)	D (mm)	Hmotnost: [kg / ks]
	80	130	IVDRM508	1 342,-	52,63	-	-	-	-	2,09
	100	150	IVDRM510	1 448,-	56,78	-	-	-	-	2,48
	130	180	IVDRM513	1 526,-	59,84	-	-	-	-	3,07
	150	200	IVDRM515	1 725,-	67,65	-	-	-	-	3,46
	180	230	IVDRM518	1 896,-	74,35	-	-	-	-	4,05
	200	250	IVDRM520	2 022,-	79,29	-	-	-	-	4,44
	250	300	IVDRM525	2 452,-	96,16	-	-	-	-	5,74
	300	350	IVDRM530	3 066,-	120,24	-	-	-	-	7,22
	350	400	IVDRM535	3 779,-	148,20	-	-	-	-	8,33
	400	450	IVDRM540	4 295,-	168,43	-	-	-	-	9,43
	450	500	IVDRM545	5 120,-	200,78	-	-	-	-	10,54
	500	550	IVDRM550	5 819,-	228,20	-	-	-	-	11,65
550	600	IVDRM555	6 064,-	237,80	-	-	-	-	12,75	

**Pozn.:**

Zvýrazněné položky v tabulkách jsou skladem. Ostatní s dodací lhůtou do 15 pracovních dnů.

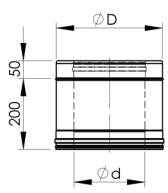
Rovný díl 200mm	Ød	ØD	Kód	Cena [Kč / ks]	Cena [€ / ks]	A (mm)	B (mm)	C (mm)	D (mm)	Hmotnost: [kg / ks]
	80	130	IVDRM008	913,-	35,80	-	-	-	-	1,07
	100	150	IVDRM010	973,-	38,16	-	-	-	-	1,26
	130	180	IVDRM013	1 071,-	42,00	-	-	-	-	1,56
	150	200	IVDRM015	1 110,-	43,53	-	-	-	-	1,76
	180	230	IVDRM018	1 204,-	47,22	-	-	-	-	2,06
	200	250	IVDRM020	1 262,-	49,49	-	-	-	-	2,26
	250	300	IVDRM025	1 559,-	61,14	-	-	-	-	2,91
	300	350	IVDRM030	1 851,-	72,59	-	-	-	-	3,66
	350	400	IVDRM035	2 247,-	88,12	-	-	-	-	4,22
	400	450	IVDRM040	2 544,-	99,76	-	-	-	-	4,78
	450	500	IVDRM045	2 822,-	110,67	-	-	-	-	5,34
	500	550	IVDRM050	3 370,-	132,16	-	-	-	-	5,90
	550	600	IVDRM055	3 587,-	140,67	-	-	-	-	6,45

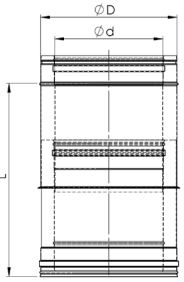
Nastav. díl kouř. 270-320mm	Ød	ØD	Kód	Cena [Kč / ks]	Cena [€ / ks]	L (mm)	B (mm)	C (mm)	D (mm)	Hmotnost: [kg / ks]	
	80	130	IVDRS308	2 178,-	85,41	270-320	-	-	-	0,96	
	100	150	IVDRS310	2 292,-	89,88	270-320	-	-	-	1,13	
	130	180	IVDRS313	2 475,-	97,06	270-320	-	-	-	1,40	
	150	200	IVDRS315	2 631,-	103,18	270-320	-	-	-	1,58	
	180	230	IVDRS318	2 813,-	110,31	270-320	-	-	-	1,85	
	200	250	IVDRS320	2 944,-	115,45	270-320	-	-	-	2,03	
	250	300	IVDRS325	3 475,-	136,27	270-320	-	-	-	2,62	
	-	-	-	-	-	-	-	-	-	-	-
	-	-	-	-	-	-	-	-	-	-	-
	-	-	-	-	-	-	-	-	-	-	-
	-	-	-	-	-	-	-	-	-	-	-
	-	-	-	-	-	-	-	-	-	-	-

Pozn.: Pro přetlak nutno použít těsnění Silikon nebo EPDM pro posuvnou část

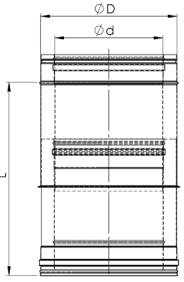
Nastav. díl kouř. 310-400mm	Ød	ØD	Kód	Cena [Kč / ks]	Cena [€ / ks]	L (mm)	B (mm)	C (mm)	D (mm)	Hmotnost: [kg / ks]
	80	130	IVDRS408	2 293,-	89,92	310-400	-	-	-	2,31
	100	150	IVDRS410	2 412,-	94,59	310-400	-	-	-	2,74
	130	180	IVDRS413	2 605,-	102,16	310-400	-	-	-	3,37
	150	200	IVDRS415	2 769,-	108,59	310-400	-	-	-	3,80
	180	230	IVDRS418	2 960,-	116,08	310-400	-	-	-	4,44
	200	250	IVDRS420	3 099,-	121,53	310-400	-	-	-	4,86
	250	300	IVDRS425	3 489,-	136,82	310-400	-	-	-	6,24
	300	350	IVDRS430	3 806,-	149,25	310-400	-	-	-	7,70
	350	400	IVDRS435	4 374,-	171,53	310-400	-	-	-	8,88
	400	450	IVDRS440	7 470,-	292,94	310-400	-	-	-	10,05
	450	500	IVDRS445	8 172,-	320,47	310-400	-	-	-	11,23
	500	550	IVDRS450	8 944,-	350,75	310-400	-	-	-	12,40
	550	600	IVDRS455	9 644,-	378,20	310-400	-	-	-	13,58

Pozn.: Pro přetlak nutno použít těsnění Silikon nebo EPDM pro posuvnou část

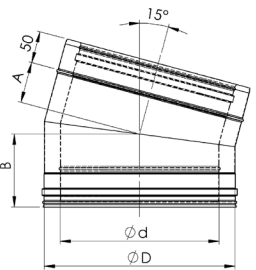
Koleno 15°	Ød	ØD	Kód	Cena [Kč / ks]	Cena [€ / ks]	A (mm)	B (mm)	C (mm)	D (mm)	Hmotnost: [kg / ks]
	80	130	IVDSB108	1 540,-	60,39	49	99	-	-	0,77
	100	150	IVDSB110	1 647,-	64,59	50	100	-	-	0,94
	130	180	IVDSB113	1 679,-	65,84	52	102	-	-	1,19
	150	200	IVDSB115	1 752,-	68,71	53	103	-	-	1,36
	180	230	IVDSB118	2 068,-	81,10	55	105	-	-	1,63
	200	250	IVDSB120	2 327,-	91,25	56	106	-	-	1,81
	250	300	IVDSB125	2 742,-	107,53	60	110	-	-	2,42
	300	350	IVDSB130	3 700,-	145,10	63	113	-	-	3,16
	350	400	IVDSB135	4 453,-	174,63	66	116	-	-	3,76
	400	450	IVDSB140	5 926,-	232,39	70	120	-	-	4,39
	450	500	IVDSB145	6 904,-	270,75	73	123	-	-	5,06
	500	550	IVDSB150	8 568,-	336,00	76	126	-	-	5,75
	550	600	IVDSB155	9 089,-	356,43	79	129	-	-	6,47

**Pozn.:**  
Zvýrazněné položky v tabulkách jsou skladem. Ostatní s dodací lhůtou do 15 pracovních dnů.

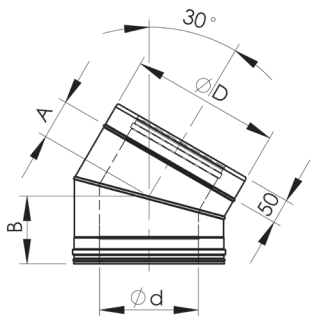

Koleno 30°	Ød	ØD	Kód	Cena [Kč / ks]	Cena [€ / ks]	A (mm)	B (mm)	C (mm)	D (mm)	Hmotnost: [kg / ks]
	80	130	IVDSB308	1 540,-	60,39	57	107	-	-	0,95
	100	150	IVDSB310	1 647,-	64,59	60	110	-	-	1,16
	130	180	IVDSB313	1 679,-	65,84	64	114	-	-	1,48
	150	200	IVDSB315	1 752,-	68,71	67	117	-	-	1,70
	180	230	IVDSB318	2 068,-	81,10	71	121	-	-	2,05
	200	250	IVDSB320	2 327,-	91,25	74	124	-	-	2,30
	250	300	IVDSB325	2 742,-	107,53	80	130	-	-	3,11
	300	350	IVDSB330	3 700,-	145,10	87	137	-	-	4,10
	350	400	IVDSB335	4 453,-	174,63	94	144	-	-	4,94
	400	450	IVDSB340	5 926,-	232,39	100	150	-	-	5,85
	450	500	IVDSB345	6 904,-	270,75	110	160	-	-	6,81
	500	550	IVDSB350	8 568,-	336,00	115	165	-	-	7,83
550	600	IVDSB355	9 089,-	356,43	120	170	-	-	8,92	

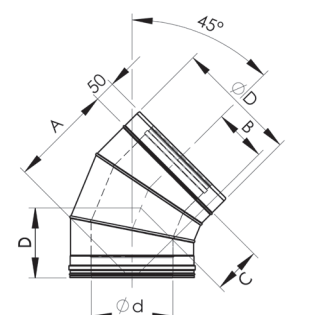
Koleno 45°	Ød	ØD	Kód	Cena [Kč / ks]	Cena [€ / ks]	A (mm)	B (mm)	C (mm)	D (mm)	Hmotnost: [kg / ks]
	80	130	IVDSB408	1 554,-	60,94	182	96	80	129	1,17
	100	150	IVDSB410	1 667,-	65,37	189	99	84	133	1,42
	130	180	IVDSB413	1 772,-	69,49	200	103	90	138	1,83
	150	200	IVDSB415	1 963,-	76,98	220	112	94	142	2,11
	180	230	IVDSB418	2 215,-	86,86	231	116	109	157	2,73
	200	250	IVDSB420	2 412,-	94,59	238	119	113	161	3,06
	250	300	IVDSB425	3 099,-	121,53	256	127	122	171	4,17
	300	350	IVDSB430	4 248,-	166,59	274	134	132	180	5,53
	350	400	IVDSB435	5 172,-	202,82	291	141	141	190	6,70
	400	450	IVDSB440	6 150,-	241,18	309	149	151	199	7,96
	450	500	IVDSB445	7 319,-	287,02	327	156	160	209	9,31
	500	550	IVDSB450	8 824,-	346,04	344	163	170	218	10,74
550	600	IVDSB455	9 400,-	368,63	362	171	179	228	12,26	

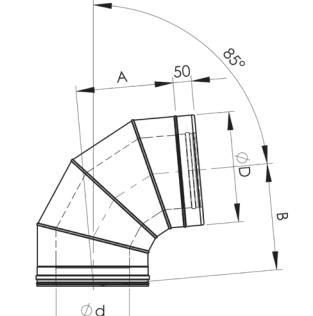
Koleno 85°	Ød	ØD	Kód	Cena [Kč / ks]	Cena [€ / ks]	A (mm)	B (mm)	C (mm)	D (mm)	Hmotnost: [kg / ks]
	80	130	IVDSB808	1 818,-	71,29	163	195	-	-	1,50
	100	150	IVDSB810	1 943,-	76,20	173	204	-	-	1,85
	130	180	IVDSB813	2 028,-	79,53	188	217	-	-	2,43
	150	200	IVDSB815	2 220,-	87,06	219	246	-	-	2,84
	180	230	IVDSB818	2 544,-	99,76	234	260	-	-	3,82
	200	250	IVDSB820	2 814,-	110,35	244	269	-	-	4,32
	250	300	IVDSB825	3 463,-	135,80	269	292	-	-	6,01
	300	350	IVDSB830	4 888,-	191,69	294	314	-	-	8,10
	350	400	IVDSB835	7 352,-	288,31	319	337	-	-	9,97
	400	450	IVDSB840	8 620,-	338,04	344	360	-	-	12,00
	450	500	IVDSB845	9 545,-	374,31	368	383	-	-	14,19
	500	550	IVDSB850	10 509,-	412,12	394	406	-	-	16,55
550	600	IVDSB855	11 454,-	449,18	418	428	-	-	19,08	

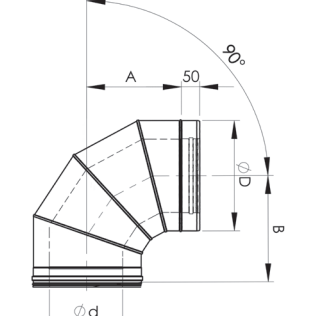
Koleno 90°	Ød	ØD	Kód	Cena [Kč / ks]	Cena [€ / ks]	A (mm)	B (mm)	C (mm)	D (mm)	Hmotnost: [kg / ks]
	80	130	IVDSB908	1 818,-	71,29	163	195	-	-	1,50
	100	150	IVDSB910	1 943,-	76,20	173	204	-	-	1,85
	130	180	IVDSB913	2 028,-	79,53	188	217	-	-	2,43
	150	200	IVDSB915	2 220,-	87,06	219	246	-	-	2,84
	180	230	IVDSB918	2 544,-	99,76	234	260	-	-	3,82
	200	250	IVDSB920	2 814,-	110,35	244	269	-	-	4,32
	250	300	IVDSB925	3 463,-	135,80	269	292	-	-	6,01
	300	350	IVDSB930	4 888,-	191,69	294	314	-	-	8,10
	350	400	IVDSB935	7 352,-	288,31	319	337	-	-	9,97
	400	450	IVDSB940	8 620,-	338,04	344	360	-	-	12,00
	450	500	IVDSB945	9 545,-	374,31	368	383	-	-	14,19
	500	550	IVDSB950	10 509,-	412,12	394	406	-	-	16,55
550	600	IVDSB955	11 454,-	449,18	418	428	-	-	19,08	

**Pozn.:**

Zvýrazněné položky v tabulkách jsou skladem. Ostatní s dodací lhůtou do 15 pracovních dnů.

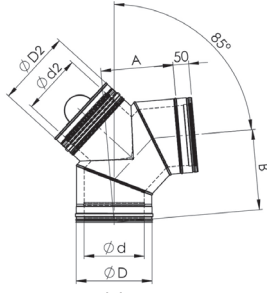
Revizní koleno 85°	Ød	ØD	Kód	Cena [Kč / ks]	Cena [€ / ks]	A (mm)	B (mm)	Ød2 (mm)	ØD2 (mm)	Hmotnost: [kg / ks]
 <p>Pozn.: Pro přetlak nutno použít těsnění Silikon pro víčko</p>	80	130	IVDRB808	5 477,-	214,78	172	203	80	130	2,94
	100	150	IVDRB810	5 662,-	222,04	184	214	80	130	3,64
	130	180	IVDRB813	5 860,-	229,80	204	232	100	150	4,79
	150	200	IVDRB815	5 992,-	234,98	217	245	100	150	5,62
	180	230	IVDRB818	6 440,-	252,55	237	263	150	200	6,96
	200	250	IVDRB820	6 500,-	254,90	250	275	150	200	7,92
	250	300	IVDRB825	7 181,-	281,61	283	305	200	250	11,17
	300	350	IVDRB830	9 016,-	353,57	316	336	250	300	15,20
	350	400	IVDRB835	11 553,-	453,06	350	366	250	300	18,92
	400	450	IVDRB840	15 105,-	592,35	383	396	250	300	23,02
	450	500	IVDRB845	17 417,-	683,02	416	427	250	300	27,49
	500	550	IVDRB850	19 868,-	779,14	449	457	250	300	32,34
550	600	IVDRB855	22 462,-	880,86	482	487	250	300	37,57	

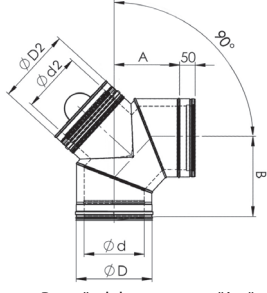
Revizní koleno 90°	Ød	ØD	Kód	Cena [Kč / ks]	Cena [€ / ks]	A (mm)	B (mm)	Ød2 (mm)	ØD2 (mm)	Hmotnost: [kg / ks]
 <p>Pozn.: Pro přetlak nutno použít těsnění Silikon pro víčko</p>	80	130	IVDRB908	5 477,-	214,78	172	203	80	130	2,94
	100	150	IVDRB910	5 662,-	222,04	184	214	80	130	3,64
	130	180	IVDRB913	5 860,-	229,80	204	232	100	150	4,79
	150	200	IVDRB915	5 992,-	234,98	217	245	100	150	5,62
	180	230	IVDRB918	6 440,-	252,55	237	263	150	200	6,96
	200	250	IVDRB920	6 500,-	254,90	250	275	150	200	7,92
	250	300	IVDRB925	7 181,-	281,61	283	305	200	250	11,17
	300	350	IVDRB930	9 016,-	353,57	316	336	250	300	15,20
	350	400	IVDRB935	11 553,-	453,06	350	366	250	300	18,92
	400	450	IVDRB940	15 105,-	592,35	383	396	250	300	23,02
	450	500	IVDRB945	17 417,-	683,02	416	427	250	300	27,49
	500	550	IVDRB950	19 868,-	779,14	449	457	250	300	32,34
550	600	IVDRB955	22 462,-	880,86	482	487	250	300	37,57	

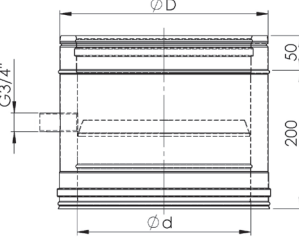
Odvěděč kondenzátu univerzální	Ød	ØD	Kód	Cena [Kč / ks]	Cena [€ / ks]	A (mm)	B (mm)	C (mm)	D (mm)	Hmotnost: [kg / ks]
	80	130	IVDKFU08	2 068,-	81,10	-	-	-	-	1,24
	100	150	IVDKFU10	2 208,-	86,59	-	-	-	-	1,47
	130	180	IVDKFU13	2 373,-	93,06	-	-	-	-	1,81
	150	200	IVDKFU15	2 459,-	96,43	-	-	-	-	2,04
	180	230	IVDKFU18	2 683,-	105,22	-	-	-	-	2,37
	200	250	IVDKFU20	2 822,-	110,67	-	-	-	-	2,60
	250	300	IVDKFU25	3 350,-	131,37	-	-	-	-	3,35
	300	350	IVDKFU30	3 766,-	147,69	-	-	-	-	4,09
	350	400	IVDKFU35	4 275,-	167,65	-	-	-	-	4,71
	400	450	IVDKFU40	4 876,-	191,22	-	-	-	-	5,34
	450	500	IVDKFU45	5 304,-	208,00	-	-	-	-	5,96
	500	550	IVDKFU50	5 734,-	224,86	-	-	-	-	6,58
550	600	IVDKFU55	6 164,-	241,73	-	-	-	-	7,21	

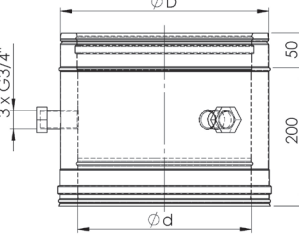
Měřicí díl	Ød	ØD	Kód	Cena [Kč / ks]	Cena [€ / ks]	A (mm)	B (mm)	C (mm)	D (mm)	Hmotnost: [kg / ks]
	80	130	IVDMSU08	2 010,-	78,82	-	-	-	-	1,55
	100	150	IVDMSU10	2 102,-	82,43	-	-	-	-	1,78
	130	180	IVDMSU13	2 188,-	85,80	-	-	-	-	2,13
	150	200	IVDMSU15	2 241,-	87,88	-	-	-	-	2,33
	180	230	IVDMSU18	2 307,-	90,47	-	-	-	-	2,68
	200	250	IVDMSU20	2 392,-	93,80	-	-	-	-	2,92
	250	300	IVDMSU25	2 703,-	106,00	-	-	-	-	3,66
	300	350	IVDMSU30	2 901,-	113,76	-	-	-	-	4,39
	350	400	IVDMSU35	3 397,-	133,22	-	-	-	-	5,02
	400	450	IVDMSU40	4 163,-	163,25	-	-	-	-	5,66
	450	500	IVDMSU45	4 949,-	194,08	-	-	-	-	6,29
	500	550	IVDMSU50	5 800,-	227,45	-	-	-	-	6,92
550	600	IVDMSU55	6 150,-	241,18	-	-	-	-	7,55	

**Pozn.:**  
Zvýrazněné položky v tabulkách jsou skladem. Ostatní s dodací lhůtou do 15 pracovních dnů.

Přechodový díl EW-DW25	Ød	ØD	Kód	Cena [Kč / ks]	Cena [€ / ks]	A (mm)	B (mm)	C (mm)	D (mm)	Hmotnost: [kg / ks]
	80	130	IVDEDU08	854,-	33,49	-	-	-	-	0,72
	100	150	IVDEDU10	940,-	36,86	-	-	-	-	0,83
	130	180	IVDEDU13	986,-	38,67	-	-	-	-	0,99
	150	200	IVDEDU15	1 098,-	43,06	-	-	-	-	1,10
	180	230	IVDEDU18	1 163,-	45,61	-	-	-	-	1,26
	200	250	IVDEDU20	1 303,-	51,10	-	-	-	-	1,37
	250	300	IVDEDU25	1 567,-	61,45	-	-	-	-	1,76
	300	350	IVDEDU30	2 068,-	81,10	-	-	-	-	2,18
	350	400	IVDEDU35	2 498,-	97,96	-	-	-	-	2,49
	400	450	IVDEDU40	3 026,-	118,67	-	-	-	-	2,81
	450	500	IVDEDU45	3 383,-	132,67	-	-	-	-	3,12
	500	550	IVDEDU50	3 727,-	146,16	-	-	-	-	3,43
	550	600	IVDEDU55	4 096,-	160,63	-	-	-	-	3,75

Přechod se zděří	Ød	ØD	Kód	Cena [Kč / ks]	Cena [€ / ks]	Ød1 (mm)	Ød2 (mm)	C (mm)	D (mm)	Hmotnost: [kg / ks]	
	150	200	IVDZDL150118	3 133,-	122,86	118	125	-	-	3,15	
	150	200	IVDZDL150128	3 153,-	123,65	128	135	-	-	3,05	
	180	230	IVDZDL180148	3 508,-	137,57	148	155	-	-	3,45	
	200	250	IVDZDL200148	3 661,-	143,57	148	155	-	-	3,75	
	200	250	IVDZDL200178	3 739,-	146,63	178	185	-	-	3,65	
	150	200	IVDZDL150148	2 531,-	99,25	148	155	-	-	1,76	
	180	230	IVDZDL180178	2 874,-	112,71	178	185	-	-	2,06	
	200	250	IVDZDL200198	3 012,-	118,12	198	205	-	-	2,26	
	-	-	-	-	-	-	-	-	-	-	-
	-	-	-	-	-	-	-	-	-	-	-
	-	-	-	-	-	-	-	-	-	-	-
	-	-	-	-	-	-	-	-	-	-	-

Hlavice a přechodový díl DW25-EW	Ød	ØD	Kód	Cena [Kč / ks]	Cena [€ / ks]	A (mm)	B (mm)	C (mm)	D (mm)	Hmotnost: [kg / ks]
	80	130	IVDDEU08	1 217,-	47,73	-	-	-	-	0,41
	100	150	IVDDEU10	1 270,-	49,80	-	-	-	-	0,46
	130	180	IVDDEU13	1 488,-	58,35	-	-	-	-	0,56
	150	200	IVDDEU15	1 606,-	62,98	-	-	-	-	0,63
	180	230	IVDDEU18	1 818,-	71,29	-	-	-	-	0,75
	200	250	IVDDEU20	1 896,-	74,35	-	-	-	-	0,83
	250	300	IVDDEU25	2 109,-	82,71	-	-	-	-	1,23
	300	350	IVDDEU30	2 300,-	90,20	-	-	-	-	1,50
	350	400	IVDDEU35	2 828,-	110,90	-	-	-	-	1,74
	400	450	IVDDEU40	3 978,-	156,00	-	-	-	-	2,03
	450	500	IVDDEU45	4 280,-	167,84	-	-	-	-	2,27
	500	550	IVDDEU50	4 519,-	177,22	-	-	-	-	2,86
	550	600	IVDDEU55	5 008,-	196,39	-	-	-	-	2,91

Klapka (podtlak)	Ød	ØD	Kód	Cena [Kč / ks]	Cena [€ / ks]	L (mm)	B (mm)	C (mm)	D (mm)	Hmotnost: [kg / ks]
	80	130	IVDHRK08	2 946,-	115,53	180	-	-	-	1,26
	100	150	IVDHRK10	3 066,-	120,24	200	-	-	-	1,62
	130	180	IVDHRK13	3 323,-	130,31	230	-	-	-	2,22
	150	200	IVDHRK15	3 522,-	138,12	250	-	-	-	2,68
	180	230	IVDHRK18	3 846,-	150,82	280	-	-	-	3,45
	200	250	IVDHRK20	4 076,-	159,84	300	-	-	-	4,01
	250	300	IVDHRK25	4 908,-	192,47	350	-	-	-	5,73
	300	350	IVDHRK30	6 507,-	255,18	400	-	-	-	8,09
	350	400	IVDHRK35	7 742,-	303,61	450	-	-	-	10,88
	400	450	IVDHRK40	8 937,-	350,47	500	-	-	-	13,62
	450	500	IVDHRK45	10 634,-	417,02	550	-	-	-	16,66
	500	550	IVDHRK50	11 975,-	469,61	600	-	-	-	20,01
	550	600	IVDHRK55	13 686,-	536,71	650	-	-	-	23,66

**Pozn.:**  
 Zvýrazněné položky v tabulkách jsou skladem. Ostatní s dodací lhůtou do 15 pracovních dnů.

Těsnění Silikon (do 200°C)	Ød	ØD	Kód	Cena [Kč / ks]	Cena [€ / ks]	A (mm)	B (mm)	C (mm)	D (mm)	Hmotnost: [kg / ks]
	80		IVEMDE08	110,-	4,31	-	-	-	-	0,01
	100		IVEMDE10	132,-	5,18	-	-	-	-	0,01
	130		IVEMDE13	189,-	7,41	-	-	-	-	0,02
	150		IVEMDE15	197,-	7,73	-	-	-	-	0,02
	180		IVEMDE18	225,-	8,82	-	-	-	-	0,02
	200		IVEMDE20	233,-	9,14	-	-	-	-	0,02
	250		IVEMDE25	284,-	11,14	-	-	-	-	0,03
	300		IVEMDE30	342,-	13,41	-	-	-	-	0,04
	350		IVEMDE35	479,-	18,78	-	-	-	-	0,04
	400		IVEMDE40	523,-	20,51	-	-	-	-	0,05
	450		IVEMDE45	559,-	21,92	-	-	-	-	0,05
	500		IVEMDE50	587,-	23,02	-	-	-	-	0,06
550		IVEMDE55	632,-	24,78	-	-	-	-	0,06	

Těsnění EPDM (do 120°C)	Ød	ØD	Kód	Cena [Kč / ks]	Cena [€ / ks]	A (mm)	B (mm)	C (mm)	D (mm)	Hmotnost: [kg / ks]	
	80		IVEMDM08	83,-	3,25	-	-	-	-	0,01	
	100		IVEMDM10	101,-	3,96	-	-	-	-	0,01	
	130		IVEMDM13	152,-	5,96	-	-	-	-	0,02	
	150		IVEMDM15	159,-	6,24	-	-	-	-	0,02	
	160		IVEMDM16	164,-	6,43	-	-	-	-	0,02	
	180		IVEMDM18	177,-	6,94	-	-	-	-	0,02	
	200		IVEMDM20	184,-	7,22	-	-	-	-	0,03	
	250		IVEMDM25	227,-	8,90	-	-	-	-	0,04	
	300		IVEMDM30	266,-	10,43	-	-	-	-	0,04	
	350		IVEMDM35	373,-	14,63	-	-	-	-	0,04	
	-		-	-	-	-	-	-	-	-	-
	-		-	-	-	-	-	-	-	-	-

Rozeta a manžeta proti zatékání	Ød	ØD	Kód	Cena [Kč / ks]	Cena [€ / ks]	A (mm)	B (mm)	C (mm)	D (mm)	Hmotnost: [kg / ks]
		130	IVEWBU13	464,-	18,20	-	-	-	-	0,57
		150	IVEWBU15	490,-	19,22	-	-	-	-	0,64
		180	IVEWBU18	530,-	20,78	-	-	-	-	0,74
		200	IVEWBU20	568,-	22,27	-	-	-	-	0,82
		230	IVEWBU23	629,-	24,67	-	-	-	-	0,94
		250	IVEWBU25	668,-	26,20	-	-	-	-	1,04
		300	IVEWBU30	774,-	30,35	-	-	-	-	1,27
		350	IVEWBU35	880,-	34,51	-	-	-	-	1,53
		400	IVEWBU40	1 210,-	47,45	-	-	-	-	2,17
		450	IVEWBU45	1 369,-	53,69	-	-	-	-	2,54
		500	IVEWBU50	1 547,-	60,67	-	-	-	-	2,94
		550	IVEWBU55	1 732,-	67,92	-	-	-	-	3,37
	600	IVEWBU60	1 931,-	75,73	-	-	-	-	3,82	

Meidingerova hlava	Ød	ØD	Kód	Cena [Kč / ks]	Cena [€ / ks]	A (mm)	L (mm)	C (mm)	D (mm)	Hmotnost: [kg / ks]
	80		IVERHU08	582,-	22,82	155	50	-	-	0,26
	100		IVERHU10	636,-	24,94	195	60	-	-	0,34
	130		IVERHU13	714,-	28,00	255	80	-	-	0,48
	150		IVERHU15	808,-	31,69	295	100	-	-	0,63
	180		IVERHU18	940,-	36,86	350	110	-	-	0,82
	200		IVERHU20	1 025,-	40,20	390	120	-	-	0,97
	250		IVERHU25	1 448,-	56,78	490	150	-	-	1,70
	300		IVERHU30	1 878,-	73,65	585	200	-	-	2,40
	350		IVERHU35	2 464,-	96,63	680	230	-	-	3,15
	400		IVERHU40	3 040,-	119,22	780	250	-	-	4,00
	450		IVERHU45	3 607,-	141,45	875	300	-	-	4,94
	500		IVERHU50	4 268,-	167,37	970	330	-	-	5,98
550		IVERHU55	4 935,-	193,53	1070	350	-	-	6,60	

Pozn.: pro uchycení Meidingerovy hlavy nutno použít sponu EW

**Pozn.:**

Zvýrazněné položky v tabulkách jsou skladem. Ostatní s dodací lhůtou do 15 pracovních dnů.

Lapač jisker	Ød	ØD	Kód	Cena [Kč / ks]	Cena [€ / ks]	ØA (mm)	L (mm)	C (mm)	D (mm)	Hmotnost: [kg / ks]
	80		IVEFGU08	1 084,-	42,51	155	50	-	-	0,25
	100		IVEFGU10	1 233,-	48,35	195	60	-	-	0,35
	130		IVEFGU13	1 471,-	57,69	255	80	-	-	0,52
	150		IVEFGU15	1 677,-	65,76	295	100	-	-	0,65
	180		IVEFGU18	1 946,-	76,31	350	110	-	-	0,87
	200		IVEFGU20	2 157,-	84,59	390	120	-	-	1,04
	250		IVEFGU25	2 979,-	116,82	490	150	-	-	1,80
	300		IVEFGU30	3 989,-	156,43	585	200	-	-	2,49
	350		IVEFGU35	5 013,-	196,59	680	230	-	-	3,28
	400		IVEFGU40	6 982,-	273,80	780	250	-	-	4,13
	450		IVEFGU45	8 647,-	339,10	875	300	-	-	5,08
	500		IVEFGU50	9 900,-	388,24	970	330	-	-	6,39
550		IVEFGU55	11 275,-	442,16	1070	350	-	-	7,26	

Pozn.: pro uchycení Lapače jisker nutno použít sponu EW

Spona EW	Ød	ØD	Kód	Cena [Kč / ks]	Cena [€ / ks]	A (mm)	B (mm)	C (mm)	D (mm)	Hmotnost: [kg / ks]
	80		IVEKLH08	120,-	4,71	-	-	-	-	0,04
	100		IVEKLH10	120,-	4,71	-	-	-	-	0,05
	130		IVEKLH13	127,-	4,98	-	-	-	-	0,05
	150		IVEKLH15	152,-	5,96	-	-	-	-	0,07
	180		IVEKLH18	167,-	6,55	-	-	-	-	0,08
	200		IVEKLH20	172,-	6,75	-	-	-	-	0,08
	250		IVEKLH25	187,-	7,33	-	-	-	-	0,10
	300		IVEKLH30	213,-	8,35	-	-	-	-	0,11
	350		IVEKLH35	239,-	9,37	-	-	-	-	0,15
	400		IVEKLH40	312,-	12,24	-	-	-	-	0,17
	450		IVEKLH45	325,-	12,75	-	-	-	-	0,19
500		IVEKLH50	337,-	13,22	-	-	-	-	0,22	

Spona DW25	Ød	ØD	Kód	Cena [Kč / ks]	Cena [€ / ks]	A (mm)	B (mm)	C (mm)	D (mm)	Hmotnost: [kg / ks]
		130	IVDKLU13	359,-	14,08	-	-	-	-	0,12
		150	IVDKLU15	364,-	14,27	-	-	-	-	0,14
		180	IVDKLU18	378,-	14,82	-	-	-	-	0,15
		200	IVDKLU20	384,-	15,06	-	-	-	-	0,16
		230	IVDKLU23	398,-	15,61	-	-	-	-	0,18
		250	IVDKLU25	404,-	15,84	-	-	-	-	0,21
		300	IVDKLU30	431,-	16,90	-	-	-	-	0,23
		350	IVDKLU35	436,-	17,10	-	-	-	-	0,27
		400	IVDKLU40	490,-	19,22	-	-	-	-	0,32
		450	IVDKLU45	503,-	19,73	-	-	-	-	0,36
		500	IVDKLU50	516,-	20,24	-	-	-	-	0,41
		550	IVDKLU55	530,-	20,78	-	-	-	-	0,45
	600	IVDKLU60	543,-	21,29	-	-	-	-	0,50	

Rozeta plochá 0-25°	Ød	ØD	Kód	Cena [Kč / ks]	Cena [€ / ks]	A (mm)	B (mm)	C (mm)	D (mm)	Hmotnost: [kg / ks]
		130	IVDWB013	524,-	20,55	-	-	-	-	1,60
		150	IVDWB015	557,-	21,84	-	-	-	-	1,70
		180	IVDWB018	622,-	24,39	-	-	-	-	1,80
		200	IVDWB020	662,-	25,96	-	-	-	-	1,90
		230	IVDWB023	728,-	28,55	-	-	-	-	2,10
		250	IVDWB025	774,-	30,35	-	-	-	-	2,20
		300	IVDWB030	900,-	35,29	-	-	-	-	2,40
		350	IVDWB035	1 019,-	39,96	-	-	-	-	2,70
		400	IVDWB040	1 342,-	52,63	-	-	-	-	2,90
		450	IVDWB045	1 515,-	59,41	-	-	-	-	3,20
		500	IVDWB050	1 699,-	66,63	-	-	-	-	3,50
		550	IVDWB055	1 890,-	74,12	-	-	-	-	3,70
	600	IVDWB060	2 161,-	84,75	-	-	-	-	4,00	

**Pozn.:**  
 Zvýrazněné položky v tabulkách jsou skladem. Ostatní s dodací lhůtou do 15 pracovních dnů.

Rozeta plochá 26-40°	Ød	ØD	Kód	Cena [Kč / ks]	Cena [€ / ks]	A (mm)	B (mm)	C (mm)	D (mm)	Hmotnost: [kg / ks]
		130	IVDWB313	524,-	20,55	-	-	-	-	1,70
		150	IVDWB315	557,-	21,84	-	-	-	-	1,80
		180	IVDWB318	622,-	24,39	-	-	-	-	1,90
		200	IVDWB320	662,-	25,96	-	-	-	-	2,00
		230	IVDWB323	728,-	28,55	-	-	-	-	2,20
		250	IVDWB325	774,-	30,35	-	-	-	-	2,30
		300	IVDWB330	900,-	35,29	-	-	-	-	2,50
		350	IVDWB335	1 019,-	39,96	-	-	-	-	3,00
		400	IVDWB340	1 342,-	52,63	-	-	-	-	3,20
		450	IVDWB345	1 515,-	59,41	-	-	-	-	3,50
		500	IVDWB350	1 699,-	66,63	-	-	-	-	4,00
		550	IVDWB355	1 890,-	74,12	-	-	-	-	4,30
	600	IVDWB360	2 161,-	84,75	-	-	-	-	4,60	

Rozeta plochá 41-45°	Ød	ØD	Kód	Cena [Kč / ks]	Cena [€ / ks]	A (mm)	B (mm)	C (mm)	D (mm)	Hmotnost: [kg / ks]
		130	IVDWB413	524,-	20,55	-	-	-	-	1,70
		150	IVDWB415	557,-	21,84	-	-	-	-	1,80
		180	IVDWB418	622,-	24,39	-	-	-	-	2,00
		200	IVDWB420	662,-	25,96	-	-	-	-	2,10
		230	IVDWB423	728,-	28,55	-	-	-	-	2,30
		250	IVDWB425	774,-	30,35	-	-	-	-	2,40
		300	IVDWB430	900,-	35,29	-	-	-	-	2,80
		350	IVDWB435	1 019,-	39,96	-	-	-	-	3,10
		400	IVDWB440	1 342,-	52,63	-	-	-	-	3,40
		450	IVDWB445	1 515,-	59,41	-	-	-	-	3,70
		500	IVDWB450	1 699,-	66,63	-	-	-	-	4,20
		550	IVDWB455	1 890,-	74,12	-	-	-	-	4,60
	600	IVDWB460	2 161,-	84,75	-	-	-	-	4,90	

Prostup střechou 0-5° s manžetou	Ød	ØD	Kód	Cena [Kč / ks]	Cena [€ / ks]	A (mm)	B (mm)	C (mm)	D (mm)	Hmotnost: [kg / ks]
		130	IVDUD013	1 712,-	67,14	590	590	-	-	0,54
		150	IVDUD015	1 772,-	69,49	610	610	-	-	2,26
		180	IVDUD018	1 890,-	74,12	640	640	-	-	2,41
		200	IVDUD020	2 036,-	79,84	660	660	-	-	2,57
		230	IVDUD023	2 293,-	89,92	690	690	-	-	3,44
		250	IVDUD025	2 670,-	104,71	710	710	-	-	3,67
		300	IVDUD030	2 946,-	115,53	760	760	-	-	4,28
		350	IVDUD035	3 522,-	138,12	810	810	-	-	4,95
		400	IVDUD040	4 651,-	182,39	860	860	-	-	5,63
		450	IVDUD045	5 324,-	208,78	910	910	-	-	6,39
		500	IVDUD050	6 005,-	235,49	960	960	-	-	7,18
		550	IVDUD055	6 744,-	264,47	1010	1010	-	-	8,01
	600	IVDUD060	7 530,-	295,29	1060	1060	-	-	8,09	

Prostup střechou 6-15° s manžetou	Ød	ØD	Kód	Cena [Kč / ks]	Cena [€ / ks]	A (mm)	B (mm)	C (mm)	D (mm)	Hmotnost: [kg / ks]
		130	IVDUD113	2 605,-	102,16	590	590	-	-	2,29
		150	IVDUD115	3 001,-	117,69	610	610	-	-	2,38
		180	IVDUD118	3 078,-	120,71	640	640	-	-	2,53
		200	IVDUD120	3 153,-	123,65	660	660	-	-	2,74
		230	IVDUD123	3 285,-	128,82	690	690	-	-	3,67
		250	IVDUD125	3 436,-	134,75	710	710	-	-	3,91
		300	IVDUD130	3 838,-	150,51	760	760	-	-	4,59
		350	IVDUD135	4 917,-	192,82	810	810	-	-	5,31
		400	IVDUD140	5 225,-	204,90	860	860	-	-	6,11
		450	IVDUD145	6 336,-	248,47	910	910	-	-	6,71
		500	IVDUD150	6 580,-	258,04	960	960	-	-	7,28
		550	IVDUD155	6 897,-	270,47	1010	1010	-	-	8,20
	600	IVDUD160	7 682,-	301,25	1060	1060	-	-	9,33	

**Pozn.:**

Zvýrazněné položky v tabulkách jsou skladem. Ostatní s dodací lhůtou do 15 pracovních dnů.

Prostup střechou 16-25° s manžetou	Ød	ØD	Kód	Cena [Kč / ks]	Cena [€ / ks]	A (mm)	B (mm)	C (mm)	D (mm)	Hmotnost: [kg / ks]
		130	IVDUD213	2 986,-	117,10	590	590	-	-	2,51
		150	IVDUD215	3 165,-	124,12	610	610	-	-	2,61
		180	IVDUD218	3 276,-	128,47	640	640	-	-	2,76
		200	IVDUD220	3 370,-	132,16	660	660	-	-	2,79
		230	IVDUD223	3 455,-	135,49	690	690	-	-	3,73
		250	IVDUD225	3 674,-	144,08	710	710	-	-	3,98
		300	IVDUD230	4 268,-	167,37	760	760	-	-	5,03
		350	IVDUD235	5 304,-	208,00	810	810	-	-	5,40
		400	IVDUD240	5 667,-	222,24	860	860	-	-	6,43
		450	IVDUD245	6 765,-	265,29	910	910	-	-	7,08
		500	IVDUD250	7 173,-	281,29	960	960	-	-	7,83
	550	IVDUD255	7 657,-	300,27	1010	1010	-	-	8,61	
	600	IVDUD260	8 521,-	334,16	1060	1060	-	-	9,69	
Prostup střechou 26-35° s manžetou	Ød	ØD	Kód	Cena [Kč / ks]	Cena [€ / ks]	A (mm)	B (mm)	C (mm)	D (mm)	Hmotnost: [kg / ks]
		130	IVDUD313	3 165,-	124,12	730	590	-	-	2,88
		150	IVDUD315	3 310,-	129,80	760	610	-	-	3,00
		180	IVDUD318	3 417,-	134,00	800	640	-	-	3,20
		200	IVDUD320	3 568,-	139,92	830	660	-	-	3,59
		230	IVDUD323	3 674,-	144,08	870	690	-	-	4,72
		250	IVDUD325	4 148,-	162,67	900	710	-	-	5,09
		300	IVDUD330	4 685,-	183,73	970	760	-	-	5,95
		350	IVDUD335	5 853,-	229,53	1040	810	-	-	6,99
		400	IVDUD340	6 288,-	246,59	1110	860	-	-	7,98
		450	IVDUD345	7 510,-	294,51	1180	910	-	-	8,78
		500	IVDUD350	8 158,-	319,92	1250	960	-	-	9,69
	550	IVDUD355	8 588,-	336,78	1320	980	-	-	10,67	
	600	IVDUD360	9 551,-	374,55	1390	980	-	-	11,70	
Prostup střechou 36-45° s manžetou	Ød	ØD	Kód	Cena [Kč / ks]	Cena [€ / ks]	A (mm)	B (mm)	C (mm)	D (mm)	Hmotnost: [kg / ks]
		130	IVDUD413	3 449,-	135,25	730	590	-	-	3,18
		150	IVDUD415	3 568,-	139,92	760	610	-	-	3,31
		180	IVDUD418	3 779,-	148,20	800	640	-	-	3,51
		200	IVDUD420	4 011,-	157,29	830	660	-	-	3,65
		230	IVDUD423	4 295,-	168,43	870	690	-	-	5,18
		250	IVDUD425	4 664,-	182,90	900	710	-	-	5,56
		300	IVDUD430	5 324,-	208,78	970	760	-	-	6,52
		350	IVDUD435	6 659,-	261,14	1040	810	-	-	7,69
		400	IVDUD440	7 280,-	285,49	1110	860	-	-	8,44
		450	IVDUD445	8 673,-	340,12	1180	910	-	-	9,29
		500	IVDUD450	9 493,-	372,27	1250	960	-	-	10,23
	550	IVDUD455	9 762,-	382,82	1320	980	-	-	11,24	
	600	IVDUD460	10 945,-	429,22	1390	980	-	-	12,31	
Prostup střechou 46-50° s manžetou	Ød	ØD	Kód	Cena [Kč / ks]	Cena [€ / ks]	A (mm)	B (mm)	C (mm)	D (mm)	Hmotnost: [kg / ks]
		130	IVDUD513	3 522,-	138,12	730	590	-	-	3,22
		150	IVDUD515	3 647,-	143,02	760	610	-	-	3,34
		180	IVDUD518	3 865,-	151,57	800	640	-	-	3,54
		200	IVDUD520	4 116,-	161,41	830	660	-	-	3,83
		230	IVDUD523	4 407,-	172,82	870	690	-	-	5,31
		250	IVDUD525	4 796,-	188,08	900	710	-	-	5,57
		300	IVDUD530	5 482,-	214,98	970	760	-	-	6,63
		350	IVDUD535	6 876,-	269,65	1040	810	-	-	7,80
		400	IVDUD540	7 491,-	293,76	1110	860	-	-	9,02
		450	IVDUD545	8 944,-	350,75	1180	910	-	-	9,93
		500	IVDUD550	9 795,-	384,12	1250	960	-	-	10,91
	550	IVDUD555	10 086,-	395,53	1320	980	-	-	11,96	
	600	IVDUD560	11 289,-	442,71	1390	980	-	-	13,07	

**Pozn.:**

Zvýrazněné položky v tabulkách jsou skladem. Ostatní s dodací lhůtou do 15 pracovních dnů.

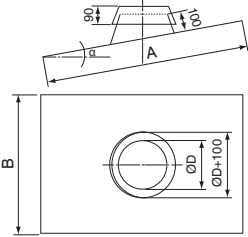
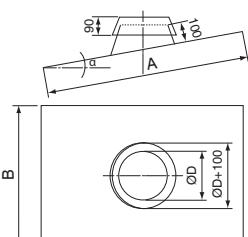
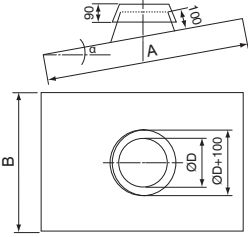
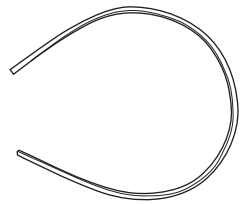
Prostup střechou ohebný 0-16° s manžetou	Ød	ØD	Kód	Cena [Kč / ks]	Cena [€ / ks]	A (mm)	B (mm)	C (mm)	D (mm)	Hmotnost: [kg / ks]
		130	IVDUDS13	5 788,-	226,98	1 060	710	-	-	3,95
		150	IVDUDS15	5 863,-	229,92	1 060	710	-	-	4,05
		180	IVDUDS18	5 976,-	234,35	1 060	710	-	-	4,60
		200	IVDUDS20	6 069,-	238,00	1 060	710	-	-	4,78
		230	IVDUDS23	6 207,-	243,41	1 060	710	-	-	5,06
		250	IVDUDS25	6 296,-	246,90	1 060	710	-	-	5,22
		300	IVDUDS30	6 566,-	257,49	1 060	710	-	-	5,73
		-	-	-	-	-	-	-	-	-
		-	-	-	-	-	-	-	-	-
		-	-	-	-	-	-	-	-	-
Prostup střechou ohebný 17-33° s manžetou	Ød	ØD	Kód	Cena [Kč / ks]	Cena [€ / ks]	A (mm)	B (mm)	C (mm)	D (mm)	Hmotnost: [kg / ks]
		130	IVDUDM13	5 845,-	229,22	1 060	710	-	-	4,14
		150	IVDUDM15	5 959,-	233,69	1 060	710	-	-	4,28
		180	IVDUDM18	6 058,-	237,57	1 060	710	-	-	5,11
		200	IVDUDM20	6 158,-	241,49	1 060	710	-	-	5,26
		230	IVDUDM23	6 311,-	247,49	1 060	710	-	-	5,50
		250	IVDUDM25	6 417,-	251,65	1 060	710	-	-	5,75
		300	IVDUDM30	6 717,-	263,41	1 060	710	-	-	6,32
		-	-	-	-	-	-	-	-	-
		-	-	-	-	-	-	-	-	-
		-	-	-	-	-	-	-	-	-
Prostup střechou ohebný 34-50° s manžetou	Ød	ØD	Kód	Cena [Kč / ks]	Cena [€ / ks]	A (mm)	B (mm)	C (mm)	D (mm)	Hmotnost: [kg / ks]
		130	IVDUDL13	5 929,-	232,51	1 060	710	-	-	4,28
		150	IVDUDL15	6 024,-	236,24	1 060	710	-	-	4,44
		180	IVDUDL18	6 174,-	242,12	1 060	710	-	-	5,27
		200	IVDUDL20	6 294,-	246,82	1 060	710	-	-	5,34
		230	IVDUDL23	6 475,-	253,92	1 060	710	-	-	5,96
		250	IVDUDL25	6 600,-	258,82	1 060	710	-	-	6,22
		300	IVDUDL30	6 954,-	272,71	1 060	710	-	-	6,89
		-	-	-	-	-	-	-	-	-
		-	-	-	-	-	-	-	-	-
		-	-	-	-	-	-	-	-	-
Těsnění pro protidešťovou manžetu	Ød	ØD	Kód	Cena [Kč / ks]	Cena [€ / ks]	A (mm)	B (mm)	C (mm)	D (mm)	Hmotnost: [kg / ks]
		130	IVEMDC13	429,-	16,82	-	-	-	-	0,06
		150	IVEMDC15	465,-	18,24	-	-	-	-	0,07
		180	IVEMDC18	523,-	20,51	-	-	-	-	0,09
		200	IVEMDC20	551,-	21,61	-	-	-	-	0,10
		230	IVEMDC23	602,-	23,61	-	-	-	-	0,11
		250	IVEMDC25	638,-	25,02	-	-	-	-	0,12
		300	IVEMDC30	719,-	28,20	-	-	-	-	0,15
		350	IVEMDC35	804,-	31,53	-	-	-	-	0,17
		400	IVEMDC40	892,-	34,98	-	-	-	-	0,19
		450	IVEMDC45	979,-	38,39	-	-	-	-	0,22
		500	IVEMDC50	1 066,-	41,80	-	-	-	-	0,24
		550	IVEMDC55	1 154,-	45,25	-	-	-	-	0,27
	600	IVEMDC60	1 233,-	48,35	-	-	-	-	0,29	

**Pozn.:**

Zvýrazněné položky v tabulkách jsou skladem. Ostatní s dodací lhůtou do 15 pracovních dnů.

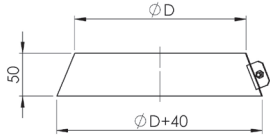

Protidešťová manžeta	Ød	ØD	Kód	Cena [Kč / ks]	Cena [€ / ks]	A (mm)	B (mm)	C (mm)	D (mm)	Hmotnost: [kg / ks]
		130	IVDWSU13	312,-	12,24	-	-	-	-	0,11
		150	IVDWSU15	345,-	13,53	-	-	-	-	0,12
		180	IVDWSU18	384,-	15,06	-	-	-	-	0,14
		200	IVDWSU20	411,-	16,12	-	-	-	-	0,16
		230	IVDWSU23	490,-	19,22	-	-	-	-	0,18
		250	IVDWSU25	530,-	20,78	-	-	-	-	0,19
		300	IVDWSU30	662,-	25,96	-	-	-	-	0,23
		350	IVDWSU35	814,-	31,92	-	-	-	-	0,26
		400	IVDWSU40	1 019,-	39,96	-	-	-	-	0,29
		450	IVDWSU45	1 204,-	47,22	-	-	-	-	0,33
		500	IVDWSU50	1 389,-	54,47	-	-	-	-	0,36
		550	IVDWSU55	1 606,-	62,98	-	-	-	-	0,39
	600	IVDWSU60	1 838,-	72,08	-	-	-	-	0,43	

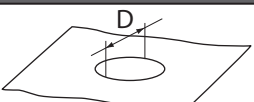
Těsnící manžeta	Ød	ØD	Kód	Cena [Kč / ks]	Cena [€ / ks]	A (mm)	B (mm)	C (mm)	D (mm)	Hmotnost: [kg / ks]
		130-150	IVDMAN15	854,-	33,49	480	560	-	75	0,25
		160-230	IVDMAN23	1 038,-	40,71	560	650	-	140	0,30
		250-350	IVDMAN35	1 415,-	55,49	680	840	-	230	0,35

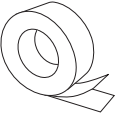
Páska pro těsnící manžetu 2500mm	Ød	ØD	Kód	Cena [Kč / ks]	Cena [€ / ks]	A (mm)	B (mm)	C (mm)	D (mm)	Hmotnost: [kg / ks]
			IVDDMB25	1 090,-	42,75	-	-	-	-	0,40

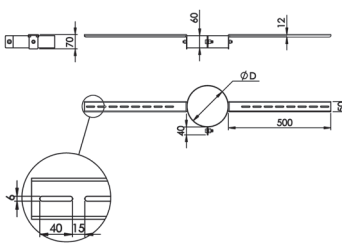
Krokový držák	Ød	ØD	Kód	Cena [Kč / ks]	Cena [€ / ks]	A (mm)	B (mm)	C (mm)	D (mm)	Hmotnost: [kg / ks]
		130	IVDDHU13	1 790,-	70,20	-	-	-	-	0,70
		150	IVDDHU15	1 824,-	71,53	-	-	-	-	0,70
		180	IVDDHU18	1 857,-	72,82	-	-	-	-	0,76
		200	IVDDHU20	1 884,-	73,88	-	-	-	-	0,80
		230	IVDDHU23	1 922,-	75,37	-	-	-	-	0,87
		250	IVDDHU25	1 956,-	76,71	-	-	-	-	0,91
		300	IVDDHU30	2 016,-	79,06	-	-	-	-	1,03
		350	IVDDHU35	2 083,-	81,69	-	-	-	-	1,14
		400	IVDDHU40	2 161,-	84,75	-	-	-	-	1,25
		450	IVDDHU45	2 233,-	87,57	-	-	-	-	1,37
		500	IVDDHU50	2 293,-	89,92	-	-	-	-	1,48
		550	IVDDHU55	2 373,-	93,06	-	-	-	-	1,59
	600	IVDDHU60	2 432,-	95,37	-	-	-	-	1,71	

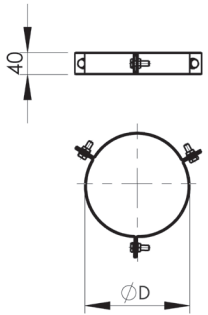
Kotvící objímka 3-bodová	Ød	ØD	Kód	Cena [Kč / ks]	Cena [€ / ks]	A (mm)	B (mm)	C (mm)	D (mm)	Hmotnost: [kg / ks]
		130	IVDSHU13	484,-	18,98	-	-	-	-	0,28
		150	IVDSHU15	490,-	19,22	-	-	-	-	0,30
		180	IVDSHU18	503,-	19,73	-	-	-	-	0,33
		200	IVDSHU20	510,-	20,00	-	-	-	-	0,35
		230	IVDSHU23	524,-	20,55	-	-	-	-	0,38
		250	IVDSHU25	536,-	21,02	-	-	-	-	0,40
		300	IVDSHU30	557,-	21,84	-	-	-	-	0,45
		350	IVDSHU35	582,-	22,82	-	-	-	-	0,50
		400	IVDSHU40	821,-	32,20	-	-	-	-	0,55
		450	IVDSHU45	854,-	33,49	-	-	-	-	0,60
		500	IVDSHU50	893,-	35,02	-	-	-	-	0,65
		550	IVDSHU55	921,-	36,12	-	-	-	-	0,70
	600	IVDSHU60	953,-	37,37	-	-	-	-	0,75	

**Pozn.:**  
 Zvýrazněné položky v tabulkách jsou skladem. Ostatní s dodací lhůtou do 15 pracovních dnů.

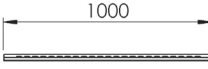
Zakládací C profil 1000mm	Ød	ØD	Kód	Cena [Kč / ks]	Cena [€ / ks]	A (mm)	B (mm)	C (mm)	D (mm)	Hmotnost: [kg / ks]
			IVDASU01	1 283,-	50,31	-	-	-	-	1,44
Pozn.: Obsahuje 2ks										

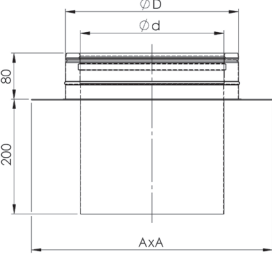

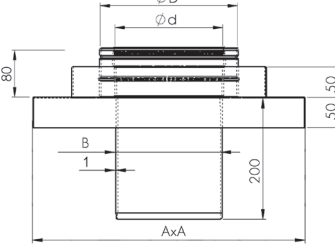
Pata komín. nástavce univ.	Ød	ØD	Kód	Cena [Kč / ks]	Cena [€ / ks]	A x A (mm)	B (mm)	C (mm)	D (mm)	Hmotnost: [kg / ks]
	80	130	IVDFSU08	1 626,-	63,76	250x250	-	-	-	1,56
	100	150	IVDFSU10	1 765,-	69,22	270x270	-	-	-	1,84
	130	180	IVDFSU13	1 943,-	76,20	300x300	-	-	-	2,27
	150	200	IVDFSU15	2 135,-	83,73	320x320	-	-	-	2,57
	180	230	IVDFSU18	2 418,-	94,82	350x350	-	-	-	3,05
	200	250	IVDFSU20	2 605,-	102,16	370x370	-	-	-	3,37
	250	300	IVDFSU25	3 534,-	138,59	420x420	-	-	-	5,12
	300	350	IVDFSU30	4 783,-	187,57	475x475	-	-	-	6,31
	350	400	IVDFSU35	6 176,-	242,20	525x525	-	-	-	8,63
	400	450	IVDFSU40	7 108,-	278,75	575x575	-	-	-	10,15
	450	500	IVDFSU45	8 072,-	316,55	625x625	-	-	-	11,77
500	550	IVDFSU50	9 156,-	359,06	675x675	-	-	-	13,49	
550	600	IVDFSU55	10 211,-	400,43	725x725	-	-	-	15,31	

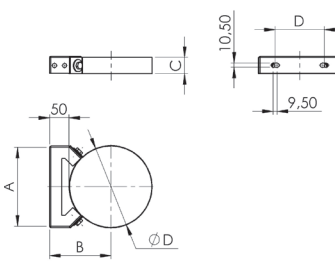
Pata komín. nástavce SIB s krycí deskou	Ød	ØD	Kód	Cena [Kč / ks]	Cena [€ / ks]	A x A (mm)	B (mm)	C (mm)	D (mm)	Hmotnost: [kg / ks]
	-	-	-	-	-	-	-	-	-	-
	-	-	-	-	-	-	-	-	-	-
	-	-	-	-	-	-	-	-	-	-
	-	-	-	-	-	-	-	-	-	-
	180	230	IVDFSK18	4 380,-	171,76	450x450	174	-	-	3,53
	200	250	IVDFSK20	4 539,-	178,00	450x450	194	-	-	3,94
	-	-	-	-	-	-	-	-	-	-
	-	-	-	-	-	-	-	-	-	-
	-	-	-	-	-	-	-	-	-	-
	-	-	-	-	-	-	-	-	-	-
	-	-	-	-	-	-	-	-	-	-
Pozn.: V případě nadstřešní instalace nutno použít rozetu a manžetu proti zatékání										

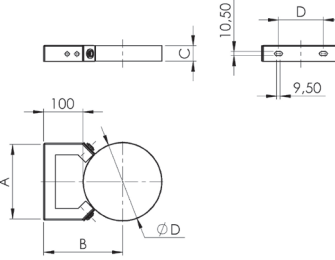
Stěnová objímka (odstup 50mm)	Ød	ØD	Kód	Cena [Kč / ks]	Cena [€ / ks]	A (mm)	B (mm)	C (mm)	D (mm)	Hmotnost: [kg / ks]
		130	IVDWHF13	866,-	33,96	148	115	40	66	0,50
		150	IVDWHF15	880,-	34,51	163	125	40	81	0,50
		180	IVDWHF18	913,-	35,80	184	140	40	102	0,50
		200	IVDWHF20	926,-	36,31	198	150	40	116	0,60
		230	IVDWHF23	946,-	37,10	219	165	40	137	0,60
		250	IVDWHF25	958,-	37,57	233	175	40	151	0,60
		300	IVDWHF30	1 005,-	39,41	269	200	40	187	0,70
		350	IVDWHF35	1 045,-	40,98	304	225	50	222	1,00
		400	IVDWHF40	1 383,-	54,24	339	250	50	257	1,00
		450	IVDWHF45	1 448,-	56,78	375	275	50	293	1,20
		500	IVDWHF50	1 633,-	64,04	410	300	50	328	1,60
	550	IVDWHF55	1 706,-	66,90	445	325	50	363	1,70	
	600	IVDWHF60	1 784,-	69,96	481	350	50	399	1,80	

Stěnová objímka (odstup 100mm)	Ød	ØD	Kód	Cena [Kč / ks]	Cena [€ / ks]	A (mm)	B (mm)	C (mm)	D (mm)	Hmotnost: [kg / ks]
		130	IVDWHU13	1 230,-	48,24	148	165	40	66	0,60
		150	IVDWHU15	1 237,-	48,51	163	175	40	81	0,60
		180	IVDWHU18	1 270,-	49,80	184	190	40	102	0,60
		200	IVDWHU20	1 283,-	50,31	198	200	40	116	0,70
		230	IVDWHU23	1 303,-	51,10	219	215	40	137	0,70
		250	IVDWHU25	1 342,-	52,63	233	225	40	151	0,70
		300	IVDWHU30	1 851,-	72,59	269	250	40	187	0,80
		-	-	-	-	-	-	-	-	-
		-	-	-	-	-	-	-	-	-
		-	-	-	-	-	-	-	-	-
		-	-	-	-	-	-	-	-	-

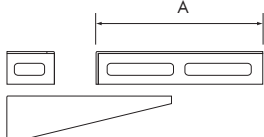
**Pozn.:**  
Zvýrazněné položky v tabulkách jsou skladem. Ostatní s dodací lhůtou do 15 pracovních dnů.

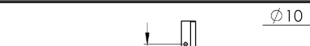
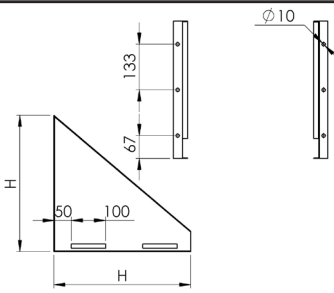
Prodloužení stěnové objímky	Ød	ØD	Kód	Cena [Kč / ks]	Cena [€ / ks]	A (mm)	B (mm)	C (mm)	D (mm)	Hmotnost: [kg / ks]
	Odstup 50-250 mm	130	IVDVH025	854,-	33,49	250	-	-	-	0,63
		150								
		180								
		200								
		230								
		250								
		300								
		350								
		400								
		450								
	Odstup 50-450 mm	130	IVDVH045	2 484,-	97,41	450	-	-	-	2,12
		150								
		180								
		200								
		230								
		250								
		300								
		350								
		400								
		450								
	Odstup 50-750 mm	130	IVDVH075	4 888,-	191,69	750	-	-	-	5,69
		150								
		180								
		200								
		230								
		250								
		300								
		350								
		400								
		450								
Konzole trojúhelníková (odstup 50-100mm)	Ød	ØD	Kód	Cena [Kč / ks]	Cena [€ / ks]	H (mm)	B (mm)	C (mm)	D (mm)	Hmotnost: [kg / ks]
 <p>Pozn.: Možnost instalace nad i pod vynášecí díl, obsahuje 2ks</p>		130	IVDWK013	946,-	37,10	230	-	-	-	1,12
		150	IVDWK015	953,-	37,37	250	-	-	-	1,28
		180	IVDWK018	966,-	37,88	280	-	-	-	1,54
		200	IVDWK020	1 085,-	42,55	300	-	-	-	1,66
		230	IVDWK023	1 230,-	48,24	330	-	-	-	1,95
		250	IVDWK025	1 289,-	50,55	350	-	-	-	2,16
		300	IVDWK030	1 896,-	74,35	400	-	-	-	2,73
		350	IVDWK035	2 200,-	86,27	450	-	-	-	3,34
		400	IVDWK040	2 412,-	94,59	500	-	-	-	4,01
		450	IVDWK045	3 574,-	140,16	550	-	-	-	4,75
		500	IVDWK050	4 136,-	162,20	600	-	-	-	5,55
		550	IVDWK055	4 696,-	184,16	650	-	-	-	6,41
		600	IVDWK060	5 304,-	208,00	700	-	-	-	7,33

**Pozn.:**

Zvýrazněné položky v tabulkách jsou skladem. Ostatní s dodací lhůtou do 15 pracovních dnů.

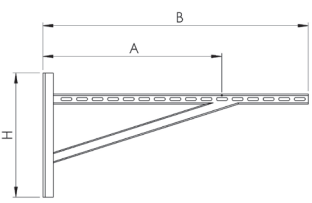
Konzole profilová	Ød	ØD	Kód	Cena [Kč / ks]	Cena [€ / ks]	Max. odstup (mm)	H (mm)	B (mm)	D (mm)	Hmotnost: [kg / ks]
 <p>Pozn.: Obsahuje 2ks</p>	500 mm	130	IVDWP050	4 007,-	157,14	310	330	500	-	3,59
		150								
		180								
		200								
		230								
		250								
		300								
		350								
		400								
		40								
	720 mm	130	IVDWP072	4 432,-	173,80	530	330	720	-	5,16
		150								
		180								
		200								
		230								
		250								
		300								
		350								
		400								
		450								
	1000 mm	130	IVDWP100	5 238,-	205,41	810	380	1000	-	6,80
		150								
		180								
		200								
		230								
		250								
		300								
		350								
		400								
		450								
500										
550										
600										
60										
690										
590										
540										
490										
440										
390										
340										

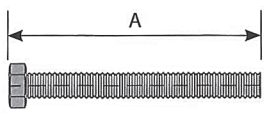
Hadice na odvod kondenzátu	Ød	Kód	Cena [Kč / ks]	Cena [€ / ks]	A (mm)	B (mm)	C (mm)	D (mm)	Hmotnost: [kg / ks]
	80	IVEWU03	345,-	13,53	300	-	-	-	-
	100	IVEWU03	345,-	13,53	300	-	-	-	-
	113	IVEWU03	345,-	13,53	300	-	-	-	-
	120	IVEWU03	345,-	13,53	300	-	-	-	-
	130	IVEWU03	345,-	13,53	300	-	-	-	-
	140	IVEWU03	345,-	13,53	300	-	-	-	-
	150	IVEWU03	345,-	13,53	300	-	-	-	-
	160	IVEWU03	345,-	13,53	300	-	-	-	-
	180	IVEWU03	345,-	13,53	300	-	-	-	-
	200	IVEWU03	345,-	13,53	300	-	-	-	-
	230	IVEWU03	345,-	13,53	300	-	-	-	-
	250	IVEWU03	345,-	13,53	300	-	-	-	-
	300	IVEWU03	345,-	13,53	300	-	-	-	-
	350	IVEWU03	345,-	13,53	300	-	-	-	-

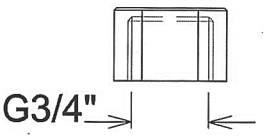
Matka mosazná	Ød	Kód	Cena [Kč / ks]	Cena [€ / ks]	A (mm)	B (mm)	C (mm)	D (mm)	Hmotnost: [kg / ks]
	80	IVEBNU00	61,-	2,39	-	-	-	-	-
	100	IVEBNU00	61,-	2,39	-	-	-	-	-
	113	IVEBNU00	61,-	2,39	-	-	-	-	-
	120	IVEBNU00	61,-	2,39	-	-	-	-	-
	130	IVEBNU00	61,-	2,39	-	-	-	-	-
	140	IVEBNU00	61,-	2,39	-	-	-	-	-
	150	IVEBNU00	61,-	2,39	-	-	-	-	-
	160	IVEBNU00	61,-	2,39	-	-	-	-	-
	180	IVEBNU00	61,-	2,39	-	-	-	-	-
	200	IVEBNU00	61,-	2,39	-	-	-	-	-
	230	IVEBNU00	61,-	2,39	-	-	-	-	-
	250	IVEBNU00	61,-	2,39	-	-	-	-	-
	300	IVEBNU00	61,-	2,39	-	-	-	-	-
	350	IVEBNU00	61,-	2,39	-	-	-	-	-

**Pozn.:** Zvýrazněné položky v tabulkách jsou skladem. Ostatní s dodací lhůtou do 15 pracovních dnů.

Centrická redukce	ød	ØD	Kód	Cena [Kč / ks]	Cena [€ / ks]	ØA (mm)	L (mm)	C (mm)	D (mm)	Hmotnost: [kg / ks]
	80	130	-	-	-	-	200	-	-	-
	100	150	IVDKKxxxxxx	2 709,-	106,24	-	200	-	-	-
	130	180	IVDKKxxxxxx	3 133,-	122,86	-	200	-	-	-
	150	200	IVDKKxxxxxx	3 265,-	128,04	-	200	-	-	-
	180	230	IVDKKxxxxxx	3 442,-	134,98	-	200	-	-	-
	200	250	IVDKKxxxxxx	3 918,-	153,65	-	200	-	-	-
	250	300	IVDKKxxxxxx	5 370,-	210,59	-	200	-	-	-
	300	350	IVDKKxxxxxx	6 507,-	255,18	-	200	-	-	-
	350	400	IVDKKxxxxxx	7 530,-	295,29	-	200	-	-	-
	400	450	IVDKKxxxxxx	8 824,-	346,04	-	200	-	-	-
	450	500	IVDKKxxxxxx	9 862,-	386,75	-	200	-	-	-
	500	550	IVDKKxxxxxx	11 157,-	437,53	-	200	-	-	-
	550	600	IVDKKxxxxxx	13 546,-	531,22	-	200	-	-	-

Excentrická redukce	ød	ØD	Kód	Cena [Kč / ks]	Cena [€ / ks]	ØA (mm)	L (mm)	C (mm)	D (mm)	Hmotnost: [kg / ks]
	80	130	-	-	-	-	200	-	-	-
	100	150	IVDKXxxxxxx	2 591,-	101,61	-	200	-	-	-
	130	180	IVDKXxxxxxx	2 564,-	100,55	-	200	-	-	-
	150	200	IVDKXxxxxxx	3 218,-	126,20	-	200	-	-	-
	180	230	IVDKXxxxxxx	3 383,-	132,67	-	200	-	-	-
	200	250	IVDKXxxxxxx	3 674,-	144,08	-	200	-	-	-
	250	300	IVDKXxxxxxx	4 275,-	167,65	-	200	-	-	-
	300	350	IVDKXxxxxxx	5 411,-	212,20	-	200	-	-	-
	350	400	IVDKXxxxxxx	6 493,-	254,63	-	200	-	-	-
	400	450	IVDKXxxxxxx	7 438,-	291,69	-	200	-	-	-
	450	500	IVDKXxxxxxx	8 580,-	336,47	-	200	-	-	-
	500	550	IVDKXxxxxxx	9 558,-	374,82	-	200	-	-	-
	550	600	IVDKXxxxxxx	10 728,-	420,71	-	200	-	-	-

**Objednávání redukci:**

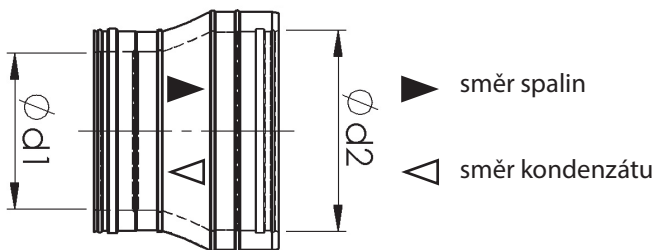

Cenu redukce určuje to DN, které je na redukci větší.  
 Rozměr ød1 je vždy vnější, rozměr ød2 je vždy vnitřní.  
 Do objednacího znaku redukce zadejte zleva do prava:  
 ød1 a ød2 v milimetrech.

**ød1 = signa**  
**ød2 = hrdlo**

Typ redukce	IVDKK xxxxxx	IVDKX xxxxxx
ød1 ( mm )		
ød2 ( mm )		

**Příklad objednávání redukci:**

Potřebuji v systému **DW25** udělat kouřovod pro odvod spalin od kotlů zapojených do kaskády a potřebuji, aby se v kouřovodu nehromadil kondenzát.  
 Dimenze se bude měnit z DN 200 mm na DN 250 mm.

**Řešení:**

Zvolím „**Redukci v systému DW25 excentrickou**“  
 S objednací znakem: **IVDKX200250**  
 Cena redukce bude stanovena podle DN 250 mm.

**Pozn.:**

Zvýrazněné položky v tabulkách jsou skladem. Ostatní s dodací lhůtou do 15 pracovních dnů.

## STATICKÁ ZAJIŠTĚNÍ DW25

DW25 Ø 80 – 550 mm

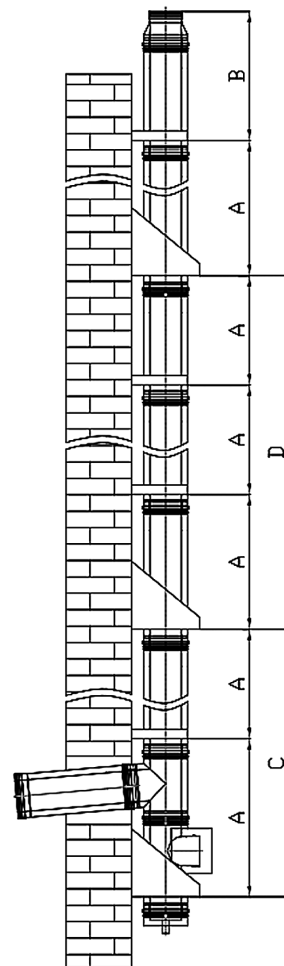
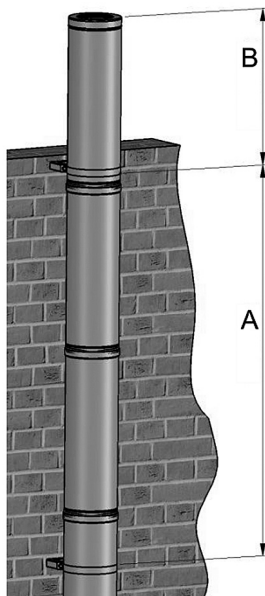
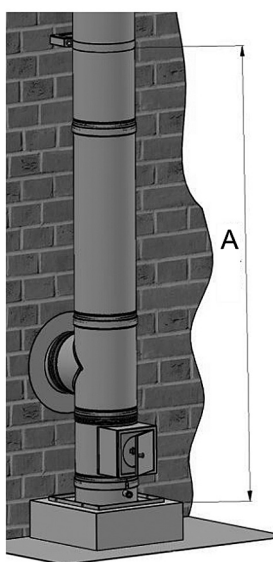

Maximální výšky v m				
Ø mm	A (m)	B (m)	C (m)	D (m)
80	3	2,5	20	20
100-250	3	2,5	15	15
300-350	2,5	1,0	10	10
400-550	2,5	1,0	5	10

### Popis:

- A – vzdálenost mezi stěnovými objímkami
- B – volně stojící délka
- C – vzdálenost mezi podpěrami
- D – vzdálenost mezi podpěrami bez sopouchu v úseku

### Kotvení horizontální části odvodu spalin:

Pokud je délka horizontální části odvodu spalin delší než 2 m, musí se kotvit. Kotvení horizontální části odvodu spalin je maximálně po 2 m.

## VARIANTA MONTÁŽE NA VODOROVNOU KONSTRUKCI DW25

Skladebná výška mezi sopouchem dvířkovým dílem v mm				
Vnitřní Ød (mm)	bez rovného dílu	s rovným dílem 200 mm	s rovným dílem 450 mm	s rovným dílem 950 mm
80	-	-	-	-
100	-	-	-	-
130	713	913	1163	1663
150	724	924	1174	1674
180	740	940	1190	1690
200	751	951	1201	1701
250	778	978	1228	1728
300	805	1005	1255	1755
350	832	1032	1282	1782
400	860	1060	1310	1810
450	887	1087	1337	1837
500	914	1114	1364	1864
550	941	1141	1391	1891

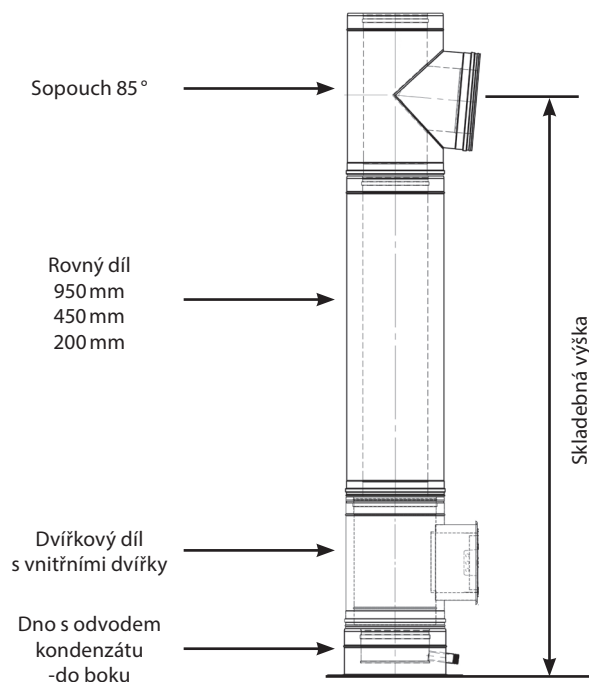

## VARIANTA MONTÁŽE NA SVISLOU KONSTRUKCI DW25

Skladebná výška mezi sopouchem a dvířkovým dílem v mm				
Vnitřní Ød (mm)	bez rovného dílu	s rovným dílem 200 mm	s rovným dílem 450 mm	s rovným dílem 950 mm
80	-	-	-	-
100	-	-	-	-
130	668	868	1118	1618
150	679	879	1129	1629
180	695	895	1145	1645
200	706	906	1156	1656
250	733	933	1183	1683
300	760	960	1210	1710
350	787	987	1237	1737
400	815	1015	1265	1765
450	842	1042	1292	1792
500	869	1069	1319	1819
550	896	1096	1346	1846

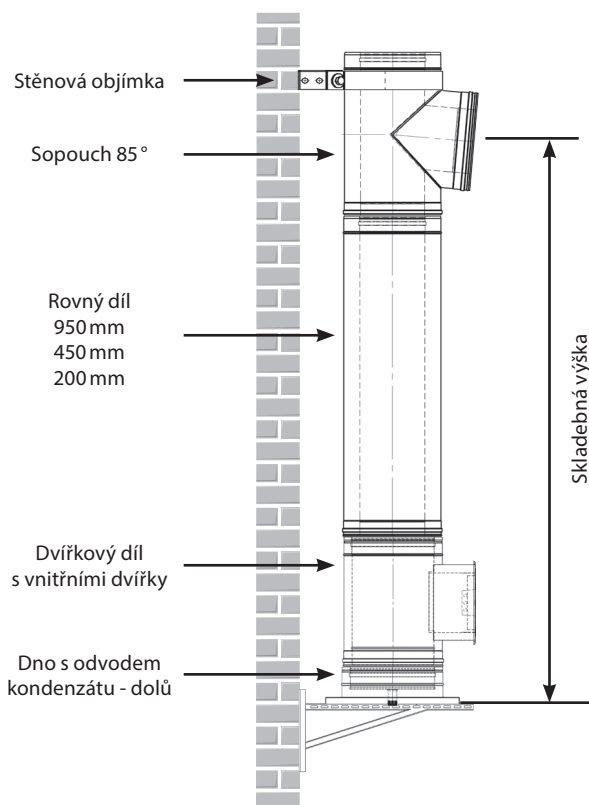

## ROZMĚRY ÚHYBŮ PRO DVĚ KOLENA A ROVNÉ DÍLY DW25

Skladebné délky mezi dvěma kolena 15° (mm)

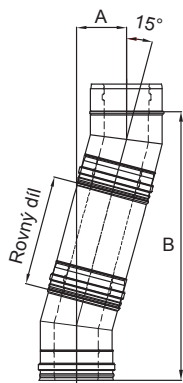

Vnitřní Ød (mm)	bez rovného dílu		s rovným dílem 200 mm		s rovným dílem 450 mm		s rovným dílem 950 mm	
	A	B	A	B	A	B	A	B
80	38	291	90	484	155	726	284	1209
100	39	295	91	488	155	730	285	1213
130	40	303	92	496	156	737	286	1220
150	40	307	92	500	157	741	286	1224
180	41	315	93	508	158	749	287	1232
200	42	318	94	512	158	753	288	1236
250	44	334	96	527	160	769	290	1252
300	46	346	97	539	162	781	291	1264
350	47	358	99	551	164	792	293	1275
400	49	374	101	567	166	808	295	1291
450	51	385	102	579	167	820	297	1303
500	52	397	104	590	169	832	298	1315
550	54	409	106	602	170	844	300	1327

Skladebné délky mezi dvěma kolena 30° (mm)

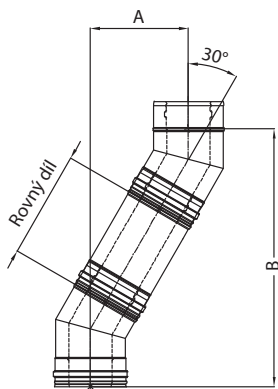

Vnitřní Ød (mm)	bez rovného dílu		s rovným dílem 200 mm		s rovným dílem 450 mm		s rovným dílem 950 mm	
	A	B	A	B	A	B	A	B
80	82	307	182	480	307	697	557	1130
100	85	317	185	490	310	707	560	1140
130	89	332	189	505	314	722	564	1155
150	92	342	192	515	317	732	567	1165
180	96	357	196	530	321	747	571	1180
200	98	367	198	540	323	757	573	1190
250	105	392	205	565	330	782	580	1215
300	112	417	211	590	337	807	587	1240
350	118	442	218	615	343	832	593	1265
400	125	467	225	640	350	857	600	1290
450	132	492	232	665	357	882	607	1315
500	139	517	239	690	364	907	614	1340
550	145	542	245	715	370	932	620	1365



## ROZMĚRY ÚHYBŮ PRO DVĚ KOLENA A ROVNÉ DÍLY DW25

Skladebné délky mezi dvěma kolena 45° (mm)								
Vnitřní Ød (mm)	bez rovného dílu		s rovným dílem 200 mm		s rovným dílem 450 mm		s rovným dílem 950 mm	
	A	B	A	B	A	B	A	B
80	153	369	294	510	471	687	825	1041
100	159	383	300	524	477	701	830	1055
130	167	404	309	546	486	722	839	1076
150	173	418	315	560	492	737	845	1090
180	197	477	339	618	515	795	869	1148
200	203	491	345	632	521	809	875	1162
250	218	526	359	668	536	844	890	1198
300	233	561	374	703	551	878	904	1233
350	247	597	389	738	565	915	919	1269
400	262	632	403	774	580	950	934	1304
450	276	668	418	809	595	986	948	1339
500	291	703	433	844	609	1021	963	1374
550	306	738	447	880	624	1056	978	1410

Skladebné délky mezi dvěma kolena 85° (mm)								
Vnitřní Ød (mm)	bez rovného dílu		s rovným dílem 200 mm		s rovným dílem 450 mm		s rovným dílem 950 mm	
	A	B	A	B	A	B	A	B
80	327	356	526	374	775	396	1273	439
100	345	376	544	394	793	416	1291	459
130	372	406	571	423	821	445	1319	489
150	390	426	590	444	839	465	1337	509
180	470	513	669	531	919	552	1417	596
200	489	533	688	551	936	572	1435	616
250	534	583	733	600	982	622	1481	666
300	580	633	779	650	1028	672	1526	716
350	625	683	825	700	1074	722	1572	765
400	671	732	870	750	1119	772	1617	815
450	717	782	916	800	1165	821	1663	865
500	762	832	962	849	1211	871	1709	915
550	808	882	1007	899	1256	921	1754	965

## PRŮCHOD KOMÍNU DW25 HOŘLAVÝMI KONSTRUKCEMI

### Zatřídění dle EN 1856-1:

DN (80 – 200) T600 – N1 – W – V2 – L50050 – G50  
 DN (250 – 300) T600 – N1 – W – V2 – L50060 – G50  
 DN (350 – 450) T600 – N1 – W – V2 – L50060 – G75  
 DN (500 – 550) T600 – N1 – W – V2 – L50060 – G100

Minimální odstup komínového pláště od hořlavých konstrukcí v mm uvádí hodnota v zatřídění za písmenem G dle průměru komína. Jedná se o provětrávanou mezeru. Platí pouze pro komíny s nelakovaným vnějším pláštěm.

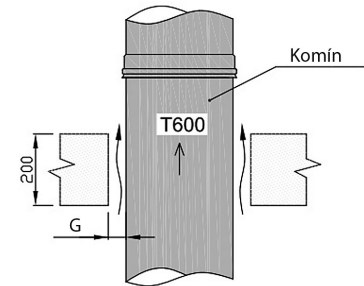

### Zatřídění dle EN 1856-1:

DN (80 – 200) T600 – N1 – W – V2 – L50050 – G100  
 DN (250 – 300) T600 – N1 – W – V2 – L50060 – G100  
 DN (350 – 450) T600 – N1 – W – V2 – L50060 – G150  
 DN (500 – 550) T600 – N1 – W – V2 – L50060 – G200

Minimální odstup komínového pláště od hořlavých konstrukcí v mm uvádí hodnota v zatřídění za písmenem G dle průměru komína. Jedná se o provětrávanou mezeru. Platí pouze pro komíny s lakovaným vnějším pláštěm.

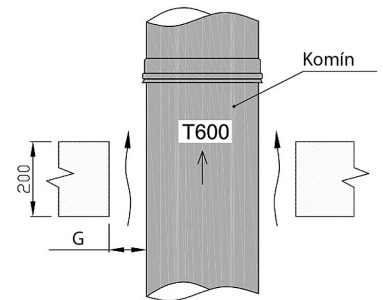

### Zatřídění dle EN 1856-1:

DN (80 – 200) T450 – N1 – W – V2 – L50050 – G100  
 DN (250 – 300) T450 – N1 – W – V2 – L50060 – G100  
 DN (350 – 450) T450 – N1 – W – V2 – L50060 – G150  
 DN (500 – 550) T450 – N1 – W – V2 – L50060 – G200

Minimální odstup komínového pláště od hořlavých konstrukcí v mm uvádí hodnota v zatřídění za písmenem G dle průměru komína. Pokud není tloušťka procházené konstrukce větší než 300 mm je mezeru vyplněna plně izolačním materiálem v tloušťce G. Pokud je tloušťka procházené konstrukce 300 - 500 mm je mezeru ve výšce 300 – 500 mm vyplněna izolačním materiálem v tloušťce poloviny G a polovina G je se vzduchovou mezerou. Jedná se o neprovětrávanou mezeru izolovanou izolačním materiálem. Platí pro komíny s lakovaným i nelakovaným vnějším pláštěm.

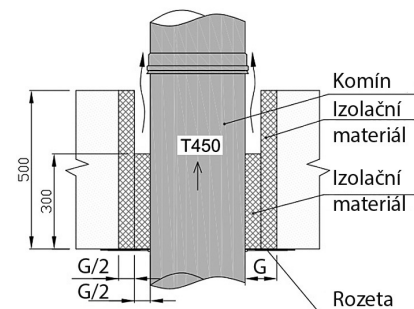

### Zatřídění dle EN 1856-1:

DN (80 – 200) T200 – P1 – W – V2 – L50050 – O50  
 DN (250 – 300) T200 – P1 – W – V2 – L50060 – O50  
 DN (350 – 450) T200 – P1 – W – V2 – L50060 – O75  
 DN (500 – 550) T200 – P1 – W – V2 – L50060 – O100

Minimální odstup komínového pláště od hořlavých konstrukcí v mm uvádí hodnota v zatřídění za písmenem O dle průměru komína. Pokud není tloušťka procházené konstrukce větší než 500 mm je mezeru vyplněna plně izolačním materiálem v tloušťce O. Platí pro komíny s lakovaným i nelakovaným vnějším pláštěm.

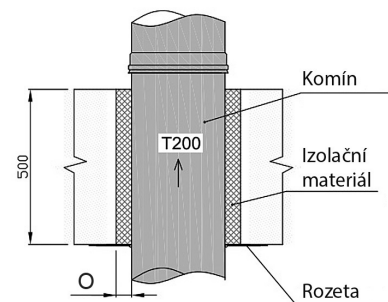

Spoje jednotlivých komínových komponentů nesmí být v místech, kde prochází podlahou, střechou nebo stěnou.

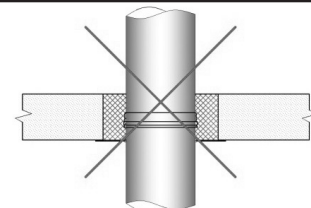





## TW25

Vícevrstvý koncentrický nerezový systém, odolný proti vlhkosti, pro podtlakový provoz.

<b>Tloušťka stěny:</b>
0,5 mm DN ≤ 200 mm
0,6 mm DN ≥ 250 mm
<b>Tloušťka izolace:</b>
25 mm
<b>Tloušťka středního pláště:</b>
0,5 mm DN ≤ 300 mm
0,6 mm DN ≥ 350 mm
<b>Tloušťka vzduchového mezikruží:</b>
25 mm
<b>Tloušťka vnějšího pláště:</b>
0,5 mm DN ≤ 300 mm
0,6 mm DN ≥ 350 mm

### Vlastnosti systému:

- vnitřní i vnější montáž
- volně stojící komíny
- systém obsahuje spony
- odolný proti vlhkosti
- pro spotřebiče nezávislé na vzduchu v místnosti

Nerezový komínový systém **ALMEVA Quadra TW25** je vhodný pro spotřebiče na pevná paliva, zejména pak kamna, která pracují v podtlakovém provozu a je nutné je připojit na externí přísávání spalovacího vzduchu.

Tento systém má širokou oblast použití pro nízkoenergetické a pasivní domy, stejně tak je vhodný pro instalaci do starších staveb, kde jsou zvýšené požadavky na přívod vzduchu.

Pro vnitřní potrubí je použita kvalitní nerezová ocel třídy 1.4404 a pro střední plášť nerezová ocel třídy 1.4301. Pro vnější plášť je z estetického hlediska použita nerezová ocel třídy 1.4301 černě lakovaná.

Kvalitní nerezová ocel třídy 1.4404 a kvalitní technické řešení umožňuje i tzv. mokrý provoz - systém je odolný vůči vlhkosti.

#### Pozn.:

Dodací lhůta do 15 pracovních dnů.

<b>Technická data pro ALMEVA Quadra TW25:</b>	
<b>Třída nerezové oceli: 1.4404 / 316L</b>	
<b>Zatřídění dle EN 1856 - 1:</b>	
TW25	EN 1856-1 T450 N1 W V2 L50050 G80 (Ø150-200 mm)
TW25	EN 1856-1 T450 N1 W V2 L50060 G80 (Ø250 mm)

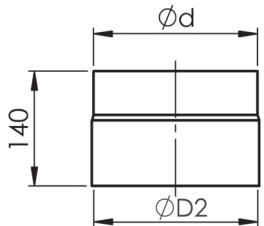
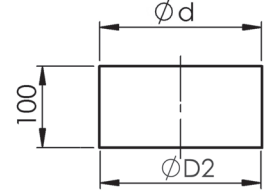
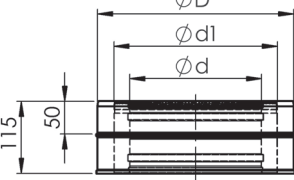
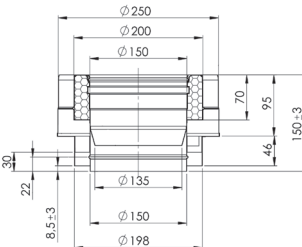
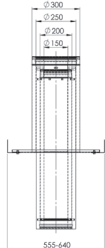
Kotlová spojka vnější	Ød	ØD	Kód	Cena [Kč / ks]	Cena [€ / ks]	Ød1	Ød2	ØD2	A (mm)	Hmotnost: [kg / ks]
	150	-	IVTKAA15	337,-	13,22	-	-	151	-	0,19
	180	-	IVTKAA18	378,-	14,82	-	-	181	-	0,23
	200	-	IVTKAA20	411,-	16,12	-	-	201	-	0,25
	250	-	IVTKAA25	516,-	20,24	-	-	251	-	0,38
	-	-	-	-	-	-	-	-	-	-
	-	-	-	-	-	-	-	-	-	-
	-	-	-	-	-	-	-	-	-	-
	-	-	-	-	-	-	-	-	-	-
	-	-	-	-	-	-	-	-	-	-
	-	-	-	-	-	-	-	-	-	-
Kotlová spojka vnitřní	Ød	ØD	Kód	Cena [Kč / ks]	Cena [€ / ks]	Ød1	Ød2	ØD2	A (mm)	Hmotnost: [kg / ks]
	150	-	IVTKAI15	451,-	17,69	-	-	149	-	0,26
	180	-	IVTKAI18	516,-	20,24	-	-	179	-	0,32
	200	-	IVTKAI20	557,-	21,84	-	-	199	-	0,35
	250	-	IVTKAI25	709,-	27,80	-	-	149	-	0,53
	-	-	-	-	-	-	-	-	-	-
	-	-	-	-	-	-	-	-	-	-
	-	-	-	-	-	-	-	-	-	-
	-	-	-	-	-	-	-	-	-	-
	-	-	-	-	-	-	-	-	-	-
	-	-	-	-	-	-	-	-	-	-
Spodní kryt	Ød	ØD	Kód	Cena [Kč / ks]	Cena [€ / ks]	Ød1	Ød2	ØD2	A (mm)	Hmotnost: [kg / ks]
	150	250	IVTETU15	1 931,-	75,73	200	-	-	-	1,69
	180	280	IVTETU18	2 300,-	90,20	230	-	-	-	1,97
	200	300	IVTETU20	2 473,-	96,98	250	-	-	-	2,17
	250	350	IVTETU25	2 934,-	115,06	300	-	-	-	2,96
	-	-	-	-	-	-	-	-	-	-
	-	-	-	-	-	-	-	-	-	-
	-	-	-	-	-	-	-	-	-	-
	-	-	-	-	-	-	-	-	-	-
	-	-	-	-	-	-	-	-	-	-
	-	-	-	-	-	-	-	-	-	-
Adapter na kamna HEARTH	Ød	ØD	Kód	Cena [Kč / ks]	Cena [€ / ks]	Ød1	Ød2	ØD2	A (mm)	Hmotnost: [kg / ks]
	150	250	IVTETH15	4 727,-	185,37	-	-	-	-	1,96
	-	-	-	-	-	-	-	-	-	-
	-	-	-	-	-	-	-	-	-	-
	-	-	-	-	-	-	-	-	-	-
	-	-	-	-	-	-	-	-	-	-
	-	-	-	-	-	-	-	-	-	-
	-	-	-	-	-	-	-	-	-	-
	-	-	-	-	-	-	-	-	-	-
	-	-	-	-	-	-	-	-	-	-
	-	-	-	-	-	-	-	-	-	-
Závěsný teleskopický díl	Ød	ØD	Kód	Cena [Kč / ks]	Cena [€ / ks]	Ød1	Ød2	ØD2	L (mm)	Hmotnost: [kg / ks]
	150	300	IVTZST15	16 542,-	648,71	-	-	-	-	-
	200	350	IVTZST20	20 182,-	791,45	-	-	-	-	-
	250	400	IVTZST25	24 982,-	979,69	-	-	-	-	-
	-	-	-	-	-	-	-	-	-	-
	-	-	-	-	-	-	-	-	-	-
	-	-	-	-	-	-	-	-	-	-
	-	-	-	-	-	-	-	-	-	-
	-	-	-	-	-	-	-	-	-	-
	-	-	-	-	-	-	-	-	-	-
	-	-	-	-	-	-	-	-	-	-

**Pozn.:**  
Dodací lhůta do 15 pracovních dnů.

Dno bez desky s odtokem kondenz. - do boku	Ød	ØD	Kód	Cena [Kč / ks]	Cena [€ / ks]	Ød1	Ød2	ØD2	A (mm)	Hmotnost: [kg / ks]
	150	250	IVTMAW15	2 043,-	80,12	200	-	-	-	1,87
	180	280	IVTMAW18	2 418,-	94,82	230	-	-	-	2,24
	200	300	IVTMAW20	2 584,-	101,33	250	-	-	-	2,49
	250	350	IVTMAW25	3 053,-	119,73	300	-	-	-	3,50
	-	-	-	-	-	-	-	-	-	-
	-	-	-	-	-	-	-	-	-	-
	-	-	-	-	-	-	-	-	-	-
	-	-	-	-	-	-	-	-	-	-
	-	-	-	-	-	-	-	-	-	-
	-	-	-	-	-	-	-	-	-	-

Vynášecí díl	Ød	ØD	Kód	Cena [Kč / ks]	Cena [€ / ks]	Ød1	Ød2	ØD2	A (mm)	Hmotnost: [kg / ks]
	150	250	IVTZSU15	3 938,-	154,43	200	-	-	350	3,60
	180	280	IVTZSU18	4 432,-	173,80	230	-	-	380	4,15
	200	300	IVTZSU20	4 737,-	185,76	250	-	-	400	4,53
	250	350	IVTZSU25	6 138,-	240,71	300	-	-	450	6,79
	-	-	-	-	-	-	-	-	-	-
	-	-	-	-	-	-	-	-	-	-
	-	-	-	-	-	-	-	-	-	-
	-	-	-	-	-	-	-	-	-	-
	-	-	-	-	-	-	-	-	-	-
	-	-	-	-	-	-	-	-	-	-

T-kus pro přívod vzduchu	Ød	ØD	Kód	Cena [Kč / ks]	Cena [€ / ks]	Ød1	Ød2	ØD2	A (mm)	Hmotnost: [kg / ks]
	150	250	IVTZT815	2 934,-	115,06	200	80	-	-	3,32
	180	280	IVTZT818	3 238,-	126,98	230	80	-	-	3,82
	200	300	IVTZT820	3 436,-	134,75	250	80	-	-	4,15
	250	350	IVTZT825	4 168,-	163,45	300	80	-	-	5,45
	-	-	-	-	-	-	-	-	-	-
	-	-	-	-	-	-	-	-	-	-
	-	-	-	-	-	-	-	-	-	-
	-	-	-	-	-	-	-	-	-	-
	-	-	-	-	-	-	-	-	-	-
	-	-	-	-	-	-	-	-	-	-

T-kus pro přívod vzduchu	Ød	ØD	Kód	Cena [Kč / ks]	Cena [€ / ks]	Ød1	Ød2	ØD2	A (mm)	Hmotnost: [kg / ks]
	150	250	IVTZT015	2 967,-	116,35	200	100	-	-	3,35
	180	280	IVTZT018	3 270,-	128,24	230	100	-	-	3,85
	200	300	IVTZT020	3 469,-	136,04	250	100	-	-	4,18
	250	350	IVTZT025	4 202,-	164,78	300	100	-	-	5,48
	-	-	-	-	-	-	-	-	-	-
	-	-	-	-	-	-	-	-	-	-
	-	-	-	-	-	-	-	-	-	-
	-	-	-	-	-	-	-	-	-	-
	-	-	-	-	-	-	-	-	-	-
	-	-	-	-	-	-	-	-	-	-

T-kus pro přívod vzduchu	Ød	ØD	Kód	Cena [Kč / ks]	Cena [€ / ks]	Ød1	Ød2	ØD2	A (mm)	Hmotnost: [kg / ks]
	150	250	IVTZT215	2 993,-	117,37	200	120	-	-	3,37
	180	280	IVTZT218	3 290,-	129,02	230	120	-	-	3,87
	200	300	IVTZT220	3 495,-	137,06	250	120	-	-	4,20
	250	350	IVTZT225	4 545,-	178,24	300	120	-	-	6,15
	-	-	-	-	-	-	-	-	-	-
	-	-	-	-	-	-	-	-	-	-
	-	-	-	-	-	-	-	-	-	-
	-	-	-	-	-	-	-	-	-	-
	-	-	-	-	-	-	-	-	-	-
	-	-	-	-	-	-	-	-	-	-

**Pozn.:**  
Dodací lhůta do 15 pracovních dnů.



Koleno 30°	Ød	ØD	Kód	Cena [Kč / ks]	Cena [€ / ks]	Ød1	Ød2	A (mm)	B (mm)	Hmotnost: [kg / ks]
	150	250	IVTSB315	3 276,-	128,47	200	-	74	124	2,98
	180	280	IVTSB318	3 654,-	143,29	230	-	78	128	3,54
	200	300	IVTSB320	3 918,-	153,65	250	-	80	130	3,93
	250	350	IVTSB325	5 133,-	201,29	300	-	87	137	5,40
	-	-	-	-	-	-	-	-	-	-
	-	-	-	-	-	-	-	-	-	-
	-	-	-	-	-	-	-	-	-	-
	-	-	-	-	-	-	-	-	-	-
	-	-	-	-	-	-	-	-	-	-
	-	-	-	-	-	-	-	-	-	-
Koleno 45°	Ød	ØD	Kód	Cena [Kč / ks]	Cena [€ / ks]	Ød1	Ød2	A (mm)	B (mm)	Hmotnost: [kg / ks]
	150	250	IVTSB415	3 931,-	154,16	200	-	238	119	3,84
	180	280	IVTSB418	4 446,-	174,35	230	-	249	124	4,58
	200	300	IVTSB420	4 796,-	188,08	250	-	256	127	5,09
	250	350	IVTSB425	6 203,-	243,25	300	-	274	134	7,06
	-	-	-	-	-	-	-	-	-	-
	-	-	-	-	-	-	-	-	-	-
	-	-	-	-	-	-	-	-	-	-
	-	-	-	-	-	-	-	-	-	-
	-	-	-	-	-	-	-	-	-	-
	-	-	-	-	-	-	-	-	-	-
Koleno 90°	Ød	ØD	Kód	Cena [Kč / ks]	Cena [€ / ks]	Ød1	Ød2	A (mm)	B (mm)	Hmotnost: [kg / ks]
	150	250	IVTSB915	5 120,-	200,78	200	-	244	269	5,51
	180	280	IVTSB918	5 866,-	230,04	230	-	259	282	6,64
	200	300	IVTSB920	6 375,-	250,00	250	-	269	292	7,43
	250	350	IVTSB925	8 535,-	334,71	300	-	294	314	10,45
	-	-	-	-	-	-	-	-	-	-
	-	-	-	-	-	-	-	-	-	-
	-	-	-	-	-	-	-	-	-	-
	-	-	-	-	-	-	-	-	-	-
	-	-	-	-	-	-	-	-	-	-
	-	-	-	-	-	-	-	-	-	-
Revizní koleno 90°	Ød	ØD	Kód	Cena [Kč / ks]	Cena [€ / ks]	Ød1	Ød2	A (mm)	B (mm)	Hmotnost: [kg / ks]
	150	250	IVTRB915	7 199,-	282,31	200	-	-	-	6,61
	180	280	IVTRB918	8 244,-	323,29	230	-	-	-	7,97
	200	300	IVTRB920	8 927,-	350,08	250	-	-	-	8,92
	250	350	IVTRB925	11 722,-	459,69	300	-	-	-	12,54
	-	-	-	-	-	-	-	-	-	-
	-	-	-	-	-	-	-	-	-	-
	-	-	-	-	-	-	-	-	-	-
	-	-	-	-	-	-	-	-	-	-
	-	-	-	-	-	-	-	-	-	-
	-	-	-	-	-	-	-	-	-	-
Vyústění s přísávaním	Ød	ØD	Kód	Cena [Kč / ks]	Cena [€ / ks]	Ød1	Ød2	ØD2	A (mm)	Hmotnost: [kg / ks]
	150	250	IVTMST15	3 475,-	136,27	200	-	-	-	3,27
	180	280	IVTMST18	3 865,-	151,57	230	-	-	-	3,84
	200	300	IVTMST20	4 148,-	162,67	250	-	-	-	4,22
	250	350	IVTMST25	5 160,-	202,35	300	-	-	-	5,49
	-	-	-	-	-	-	-	-	-	-
	-	-	-	-	-	-	-	-	-	-
	-	-	-	-	-	-	-	-	-	-
	-	-	-	-	-	-	-	-	-	-
	-	-	-	-	-	-	-	-	-	-
	-	-	-	-	-	-	-	-	-	-

**Pozn.:**  
Dodací lhůta do 15 pracovních dnů.



# VÍCEVRSTVÝ KONCENTRICKÝ NEREZOVÝ SYSTÉM

## DN 150 – 250 mm

# TW25

Nerez / izolace / nerez / lakovaná nerez

Přechodový díl na 2x izolovaný	Ød	ØD	Kód	Cena [Kč / ks]	Cena [€ / ks]	Ød1	Ød2	ØD2	A (mm)	Hmotnost: [kg / ks]
	150	300	IVTT2U15	3 144,-	123,29	200	250	-	-	3,19
	180	350	IVTT2U18	3 865,-	151,57	230	300	-	-	4,12
	200	350	IVTT2U20	3 978,-	156,00	250	300	-	-	4,29
	250	400	IVTT2U25	4 597,-	180,27	300	350	-	-	5,52
	-	-	-	-	-	-	-	-	-	-
	-	-	-	-	-	-	-	-	-	-
	-	-	-	-	-	-	-	-	-	-
	-	-	-	-	-	-	-	-	-	-
	-	-	-	-	-	-	-	-	-	-
	-	-	-	-	-	-	-	-	-	-
Rovný díl 950mm, 2x izolovaný	Ød	ØD	Kód	Cena [Kč / ks]	Cena [€ / ks]	Ød1	Ød2	ØD2	A (mm)	Hmotnost: [kg / ks]
	150	300	IVTR2115	8 845,-	346,86	200	250	-	-	18,95
	180	350	IVTR2118	10 707,-	419,88	230	300	-	-	23,19
	200	350	IVTR2120	11 024,-	432,31	250	300	-	-	24,03
	250	400	IVTR2125	13 758,-	539,53	300	350	-	-	29,85
	-	-	-	-	-	-	-	-	-	-
	-	-	-	-	-	-	-	-	-	-
	-	-	-	-	-	-	-	-	-	-
	-	-	-	-	-	-	-	-	-	-
	-	-	-	-	-	-	-	-	-	-
	-	-	-	-	-	-	-	-	-	-
Rovný díl 450mm, 2x izolovaný	Ød	ØD	Kód	Cena [Kč / ks]	Cena [€ / ks]	Ød1	Ød2	ØD2	A (mm)	Hmotnost: [kg / ks]
	150	300	IVTR2515	5 766,-	226,12	200	250	-	-	9,48
	200	350	IVTR2520	7 073,-	277,37	250	300	-	-	12,01
	250	400	IVTR2525	8 808,-	345,41	300	350	-	-	14,93
	-	-	-	-	-	-	-	-	-	-
	-	-	-	-	-	-	-	-	-	-
	-	-	-	-	-	-	-	-	-	-
	-	-	-	-	-	-	-	-	-	-
	-	-	-	-	-	-	-	-	-	-
	-	-	-	-	-	-	-	-	-	-
	-	-	-	-	-	-	-	-	-	-
Rovný díl 200mm, 2x izolovaný	Ød	ØD	Kód	Cena [Kč / ks]	Cena [€ / ks]	Ød1	Ød2	ØD2	A (mm)	Hmotnost: [kg / ks]
	150	300	IVTR2015	3 870,-	151,76	200	250	-	-	4,74
	200	350	IVTR2020	4 576,-	179,45	250	300	-	-	6,01
	250	400	IVTR2025	5 563,-	218,16	300	350	-	-	7,46
	-	-	-	-	-	-	-	-	-	-
	-	-	-	-	-	-	-	-	-	-
	-	-	-	-	-	-	-	-	-	-
	-	-	-	-	-	-	-	-	-	-
	-	-	-	-	-	-	-	-	-	-
	-	-	-	-	-	-	-	-	-	-
	-	-	-	-	-	-	-	-	-	-
Koleno 30°, 2x izolované	Ød	ØD	Kód	Cena [Kč / ks]	Cena [€ / ks]	Ød1	Ød2	ØD2	A (mm)	Hmotnost: [kg / ks]
	150	300	IVTB2315	5 666,-	222,20	200	250	-	-	-
	200	350	IVTB2320	7 008,-	274,82	250	300	-	-	-
	250	400	IVTB2325	9 042,-	354,59	300	350	-	-	-
	-	-	-	-	-	-	-	-	-	-
	-	-	-	-	-	-	-	-	-	-
	-	-	-	-	-	-	-	-	-	-
	-	-	-	-	-	-	-	-	-	-
	-	-	-	-	-	-	-	-	-	-
	-	-	-	-	-	-	-	-	-	-
	-	-	-	-	-	-	-	-	-	-

**Pozn.:**  
Dodací lhůta do 15 pracovních dnů.

Koleno 45°, 2x izolované	Ød	ØD	Kód	Cena [Kč / ks]	Cena [€ / ks]	Ød1	Ød2	ØD2	A (mm)	Hmotnost: [kg / ks]
	150	300	IVTB2415	6 419,-	251,73	200	250	-	-	-
	200	350	IVTB2420	8 005,-	313,92	250	300	-	-	-
	250	400	IVTB2425	10 515,-	412,35	300	350	-	-	-
	-	-	-	-	-	-	-	-	-	-
	-	-	-	-	-	-	-	-	-	-
	-	-	-	-	-	-	-	-	-	-
	-	-	-	-	-	-	-	-	-	-
	-	-	-	-	-	-	-	-	-	-

Vyústění s přísáváním, 2x izolovaný	Ød	ØD	Kód	Cena [Kč / ks]	Cena [€ / ks]	Ød1	Ød2	ØD2	A (mm)	Hmotnost: [kg / ks]
	150	300	IVTMS215	4 744,-	186,04	200	250	-	-	4,30
	180	350	IVTMS218	5 622,-	220,47	230	300	-	-	5,44
	200	350	IVTMS220	5 748,-	225,41	250	300	-	-	5,69
	250	400	IVTMS225	6 765,-	265,29	300	350	-	-	7,25
	-	-	-	-	-	-	-	-	-	-
	-	-	-	-	-	-	-	-	-	-
	-	-	-	-	-	-	-	-	-	-
	-	-	-	-	-	-	-	-	-	-

Rozeta a manžeta proti zatékání	Ød	ØD	Kód	Cena [Kč / ks]	Cena [€ / ks]	A (mm)	B (mm)	C (mm)	D (mm)	Hmotnost: [kg / ks]
	-	250	IVTWBU25	841,-	32,98	-	-	-	-	0,30
	-	280	IVTWBU28	966,-	37,88	-	-	-	-	0,30
	-	300	IVTWBU30	973,-	38,16	-	-	-	-	0,30
	-	350	IVTWBU35	1 118,-	43,84	-	-	-	-	0,40
	-	400	IVTWBU40	1 534,-	60,16	-	-	-	-	0,50
	-	-	-	-	-	-	-	-	-	-
	-	-	-	-	-	-	-	-	-	-
	-	-	-	-	-	-	-	-	-	-

Meidingerova hlava	Ød	ØD	Kód	Cena [Kč / ks]	Cena [€ / ks]	A (mm)	L (mm)	C (mm)	D (mm)	Hmotnost: [kg / ks]
<p>Pozn.: pro uchycení Meidingerovy hlavy nutno použít sponu TW25</p>	150	-	IVTRHU15	973,-	38,16	295	100	-	-	0,63
	180	-	IVTRHU18	1 130,-	44,31	350	110	-	-	0,82
	200	-	IVTRHU20	1 230,-	48,24	390	120	-	-	0,97
	250	-	IVTRHU25	1 738,-	68,16	490	150	-	-	1,70
	-	-	-	-	-	-	-	-	-	-
	-	-	-	-	-	-	-	-	-	-
	-	-	-	-	-	-	-	-	-	-
	-	-	-	-	-	-	-	-	-	-

Spona pro Meidingerovu hlavu TW25	Ød	ØD	Kód	Cena [Kč / ks]	Cena [€ / ks]	Ød1	Ød2	ØD2	A (mm)	Hmotnost: [kg / ks]
	150	-	IVTKLH15	187,-	7,33	-	-	-	-	0,06
	180	-	IVTKLH18	200,-	7,84	-	-	-	-	0,07
	200	-	IVTKLH20	213,-	8,35	-	-	-	-	0,07
	250	-	IVTKLH25	227,-	8,90	-	-	-	-	0,08
	-	-	-	-	-	-	-	-	-	-
	-	-	-	-	-	-	-	-	-	-
	-	-	-	-	-	-	-	-	-	-
	-	-	-	-	-	-	-	-	-	-

**Pozn.:**  
Dodací lhůta do 15 pracovních dnů.



Prostup střechou 6-15° s manžetou	Ød	ØD	Kód	Cena [Kč / ks]	Cena [€ / ks]	A (mm)	B (mm)	C (mm)	D (mm)	Hmotnost: [kg / ks]
	-	250	IVTUD125	4 123,-	161,69	710	710	-	-	3,91
	-	280	IVTUD128	4 380,-	171,76	740	740	-	-	4,30
	-	300	IVTUD130	4 612,-	180,86	760	760	-	-	4,59
	-	350	IVTUD135	5 899,-	231,33	810	810	-	-	5,31
	-	400	IVTUD140	6 620,-	259,61	860	860	-	-	6,11
	-	-	-	-	-	-	-	-	-	-
	-	-	-	-	-	-	-	-	-	-
	-	-	-	-	-	-	-	-	-	-
	-	-	-	-	-	-	-	-	-	-
	-	-	-	-	-	-	-	-	-	-
Prostup střechou 16-25° s manžetou	Ød	ØD	Kód	Cena [Kč / ks]	Cena [€ / ks]	A (mm)	B (mm)	C (mm)	D (mm)	Hmotnost: [kg / ks]
	-	250	IVTUD225	4 412,-	173,02	710	710	-	-	3,98
	-	280	IVTUD228	4 849,-	190,16	740	740	-	-	4,74
	-	300	IVTUD230	5 126,-	201,02	760	760	-	-	5,03
	-	350	IVTUD235	6 368,-	249,73	810	810	-	-	5,40
	-	400	IVTUD240	7 214,-	282,90	860	860	-	-	6,43
	-	-	-	-	-	-	-	-	-	-
	-	-	-	-	-	-	-	-	-	-
	-	-	-	-	-	-	-	-	-	-
	-	-	-	-	-	-	-	-	-	-
	-	-	-	-	-	-	-	-	-	-
Prostup střechou 26-35° s manžetou	Ød	ØD	Kód	Cena [Kč / ks]	Cena [€ / ks]	A (mm)	B (mm)	C (mm)	D (mm)	Hmotnost: [kg / ks]
	-	250	IVTUD325	4 982,-	195,37	900	710	-	-	5,09
	-	280	IVTUD328	5 404,-	211,92	940	740	-	-	5,60
	-	300	IVTUD330	5 622,-	220,47	1040	810	-	-	5,95
	-	350	IVTUD335	7 029,-	275,65	1110	860	-	-	6,99
	-	400	IVTUD340	7 874,-	308,78	1180	910	-	-	7,98
	-	-	-	-	-	-	-	-	-	-
	-	-	-	-	-	-	-	-	-	-
	-	-	-	-	-	-	-	-	-	-
	-	-	-	-	-	-	-	-	-	-
	-	-	-	-	-	-	-	-	-	-
Prostup střechou 36-45° s manžetou	Ød	ØD	Kód	Cena [Kč / ks]	Cena [€ / ks]	A (mm)	B (mm)	C (mm)	D (mm)	Hmotnost: [kg / ks]
	-	250	IVTUD425	5 602,-	219,69	900	710	-	-	5,56
	-	280	IVTUD428	6 083,-	238,55	940	740	-	-	6,08
	-	300	IVTUD430	6 394,-	250,75	1040	810	-	-	6,52
	-	350	IVTUD435	7 993,-	313,45	1110	860	-	-	7,69
	-	400	IVTUD440	8 872,-	347,92	1180	910	-	-	8,44
	-	-	-	-	-	-	-	-	-	-
	-	-	-	-	-	-	-	-	-	-
	-	-	-	-	-	-	-	-	-	-
	-	-	-	-	-	-	-	-	-	-
	-	-	-	-	-	-	-	-	-	-
Prostup střechou 46-50° s manžetou	Ød	ØD	Kód	Cena [Kč / ks]	Cena [€ / ks]	A (mm)	B (mm)	C (mm)	D (mm)	Hmotnost: [kg / ks]
	-	250	IVTUD525	5 761,-	225,92	900	710	-	-	5,57
	-	280	IVTUD528	6 262,-	245,57	940	740	-	-	6,19
	-	300	IVTUD530	6 580,-	258,04	1040	810	-	-	6,63
	-	350	IVTUD535	8 256,-	323,76	1110	860	-	-	7,80
	-	400	IVTUD540	9 228,-	361,88	1180	910	-	-	9,02
	-	-	-	-	-	-	-	-	-	-
	-	-	-	-	-	-	-	-	-	-
	-	-	-	-	-	-	-	-	-	-
	-	-	-	-	-	-	-	-	-	-
	-	-	-	-	-	-	-	-	-	-

**Pozn.:**  
Dodací lhůta do 15 pracovních dnů.

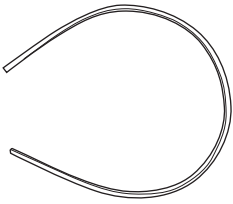
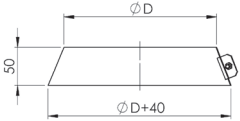
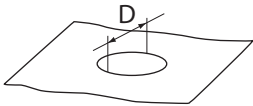
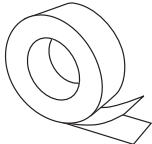
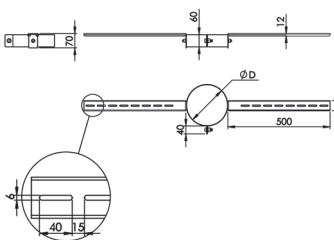
Těsnění pro protidešťovou manžetu	Ød	ØD	Kód	Cena [Kč / ks]	Cena [€ / ks]	A (mm)	B (mm)	C (mm)	D (mm)	Hmotnost: [kg / ks]
	-	250	IVEMDC25	638,-	25,02	-	-	-	-	0,12
	-	280	IVEMDC28	586,-	22,98	-	-	-	-	0,14
	-	300	IVEMDC30	719,-	28,20	-	-	-	-	0,15
	-	350	IVEMDC35	804,-	31,53	-	-	-	-	0,17
	-	400	IVEMDC40	892,-	34,98	-	-	-	-	0,19
	-	-	-	-	-	-	-	-	-	-
	-	-	-	-	-	-	-	-	-	-
	-	-	-	-	-	-	-	-	-	-
	-	-	-	-	-	-	-	-	-	-
	-	-	-	-	-	-	-	-	-	-
Protidešťová manžeta	Ød	ØD	Kód	Cena [Kč / ks]	Cena [€ / ks]	A (mm)	B (mm)	C (mm)	D (mm)	Hmotnost: [kg / ks]
	-	250	IVTWSU25	668,-	26,20	-	-	-	-	0,19
	-	280	IVTWSU28	841,-	32,98	-	-	-	-	0,20
	-	300	IVTWSU30	932,-	36,55	-	-	-	-	0,23
	-	350	IVTWSU35	1 032,-	40,47	-	-	-	-	0,26
	-	400	IVTWSU40	1 289,-	50,55	-	-	-	-	0,29
	-	-	-	-	-	-	-	-	-	-
	-	-	-	-	-	-	-	-	-	-
	-	-	-	-	-	-	-	-	-	-
	-	-	-	-	-	-	-	-	-	-
	-	-	-	-	-	-	-	-	-	-
Těsnící manžeta	Ød	ØD	Kód	Cena [Kč / ks]	Cena [€ / ks]	A (mm)	B (mm)	C (mm)	D (mm)	Hmotnost: [kg / ks]
	-	250-350	IVDMAN35	1 415,-	55,49	680	840	-	230	0,35
Páska pro těsnící manžetu 2500mm	Ød	ØD	Kód	Cena [Kč / ks]	Cena [€ / ks]	A (mm)	B (mm)	C (mm)	D (mm)	Hmotnost: [kg / ks]
	-	-	IVDDMB25	1 090,-	42,75	-	-	-	-	0,40
Krokvový držák	Ød	ØD	Kód	Cena [Kč / ks]	Cena [€ / ks]	A (mm)	B (mm)	C (mm)	D (mm)	Hmotnost: [kg / ks]
	-	250	IVDDHU25	1 956,-	76,71	-	-	-	-	0,91
	-	280	IVDDHU28	1 988,-	77,96	-	-	-	-	0,33
	-	300	IVDDHU30	2 016,-	79,06	-	-	-	-	1,03
	-	350	IVDDHU35	2 083,-	81,69	-	-	-	-	1,14
	-	400	IVDDHU40	2 161,-	84,75	-	-	-	-	1,25
	-	-	-	-	-	-	-	-	-	-
	-	-	-	-	-	-	-	-	-	-
	-	-	-	-	-	-	-	-	-	-
	-	-	-	-	-	-	-	-	-	-
	-	-	-	-	-	-	-	-	-	-

Pozn.: Nelakováno

Pozn.: Dodací lhůta do 15 pracovních dnů.

Kotvicí objímka 3-bodová	Ød	ØD	Kód	Cena [Kč / ks]	Cena [€ / ks]	A (mm)	B (mm)	C (mm)	D (mm)	Hmotnost: [kg / ks]
	-	250	IVTSHU25	675,-	26,47	-	-	-	-	0,41
	-	280	IVTSHU28	689,-	27,02	-	-	-	-	0,45
	-	300	IVTSHU30	701,-	27,49	-	-	-	-	0,50
	-	350	IVTSHU35	728,-	28,55	-	-	-	-	0,55
	-	400	IVTSHU40	1 038,-	40,71	-	-	-	-	0,60
	-	-	-	-	-	-	-	-	-	-
	-	-	-	-	-	-	-	-	-	-
	-	-	-	-	-	-	-	-	-	-
	-	-	-	-	-	-	-	-	-	-
	-	-	-	-	-	-	-	-	-	-

Zakládací C profil 1000mm	Ød	ØD	Kód	Cena [Kč / ks]	Cena [€ / ks]	A (mm)	B (mm)	C (mm)	D (mm)	Hmotnost: [kg / ks]
			IVDASU01	1 283,-	50,31	-	-	-	-	1,44

Pozn.: Obsahuje 2ks

Stěnová objímka (odstup 50mm)	Ød	ØD	Kód	Cena [Kč / ks]	Cena [€ / ks]	A (mm)	B (mm)	C (mm)	D (mm)	Hmotnost: [kg / ks]
	-	250	IVTWHF25	1 257,-	49,29	233	175	40	151	0,60
	-	280	IVTWHF28	1 289,-	50,55	261	190	40	175	0,70
	-	300	IVTWHF30	1 309,-	51,33	269	200	40	187	0,70
	-	350	IVTWHF35	1 362,-	53,41	304	225	50	222	1,00
	-	400	IVTWHF40	1 752,-	68,71	339	250	50	257	1,00
	-	-	-	-	-	-	-	-	-	-
	-	-	-	-	-	-	-	-	-	-
	-	-	-	-	-	-	-	-	-	-
	-	-	-	-	-	-	-	-	-	-
	-	-	-	-	-	-	-	-	-	-

Stěnová objímka (odstup 100mm)	Ød	ØD	Kód	Cena [Kč / ks]	Cena [€ / ks]	A (mm)	B (mm)	C (mm)	D (mm)	Hmotnost: [kg / ks]
	-	250	IVTWHU25	1 614,-	63,29	233	225	40	151	0,80
	-	280	IVTWHU28	1 976,-	77,49	261	240	40	175	0,80
	-	300	IVTWHU30	2 220,-	87,06	269	250	40	187	0,75
	-	-	-	-	-	-	-	-	-	-
	-	-	-	-	-	-	-	-	-	-
	-	-	-	-	-	-	-	-	-	-
	-	-	-	-	-	-	-	-	-	-
	-	-	-	-	-	-	-	-	-	-
	-	-	-	-	-	-	-	-	-	-
	-	-	-	-	-	-	-	-	-	-

**Pozn.:**  
Dodací lhůta do 15 pracovních dnů.

# VÍCEVRSTVÝ KONCENTRICKÝ NEREZOVÝ SYSTÉM

## DN 150 – 250 mm

# TW25

Nerez / izolace / nerez / lakovaná nerez

Prodloužení stěnové objímky		Ød	ØD	Kód	Cena [Kč / ks]	Cena [€ / ks]	A (mm)	B (mm)	C (mm)	D (mm)	Hmotnost: [kg / ks]	
	Odstup 50-250 mm	-	250	IVTVH025	1 025,-	40,20	250	-	-	-	1,00	
		-	280									
		-	300									
		-	-	-	-	-	-	-	-	-	-	-
		-	-	-	-	-	-	-	-	-	-	-
		-	-	-	-	-	-	-	-	-	-	-
		-	-	-	-	-	-	-	-	-	-	-
		-	-	-	-	-	-	-	-	-	-	-
	Odstup 50-270 mm	-	350	IVTVH027	2 722,-	106,75	270	-	-	-	2,41	
		-	400									
		-	-	-	-	-	-	-	-	-	-	-
		-	-	-	-	-	-	-	-	-	-	-
	Odstup 50-450 mm	-	250	IVTVH045	3 489,-	136,82	450	-	-	-	-	6,23
		-	280									
		-	300									
		-	-	-	-	-	-	-	-	-	-	-
	Odstup 50-750 mm	-	250	IVTVH075	6 836,-	268,08	750	-	-	-	-	5,38
		-	280									
		-	300									
		-	-	-	-	-	-	-	-	-	-	-
-	-	-	-	-	-	-	-	-	-	-	-	

  

Konzole trojúhelníková (odstup 50-100 mm)		Ød	ØD	Kód	Cena [Kč / ks]	Cena [€ / ks]	H (mm)	B (mm)	C (mm)	D (mm)	Hmotnost: [kg / ks]	
<p>Pozn.: Možnost instalace nad i pod vynášecí díl, obsahuje 2ks</p>	-	250	IVTWK025	1 547,-	60,67	350	-	-	-	-	2,84	
		280	IVTWK028	1 963,-	76,98	380	-	-	-	-	-	3,30
		300	IVTWK030	2 280,-	89,41	400	-	-	-	-	-	3,50
		350	IVTWK035	2 643,-	103,65	450	-	-	-	-	-	5,62
		-	-	-	-	-	-	-	-	-	-	-
	-	-	-	-	-	-	-	-	-	-	-	
	-	-	-	-	-	-	-	-	-	-	-	
	-	-	-	-	-	-	-	-	-	-	-	
	-	-	-	-	-	-	-	-	-	-	-	
	-	-	-	-	-	-	-	-	-	-	-	
	-	-	-	-	-	-	-	-	-	-	-	

  

Konzole profilová		Ød	ØD	Kód	Cena [Kč / ks]	Cena [€ / ks]	H (mm)	A (mm)	B (mm)	C (mm)	Hmotnost: [kg / ks]
<p>Pozn.: Obsahuje 2ks</p>	720 mm	-	250	IVTWP072	6 210,-	243,53	330	-	720	-	7,06
		-	280								
		-	300								
		-	350								
	1000 mm	-	250	IVTWP100	7 332,-	287,53	380	-	1000	-	0,14
		-	280								
		-	300								
		-	350								

**Pozn.:**  
Dodací lhůta do 15 pracovních dnů.

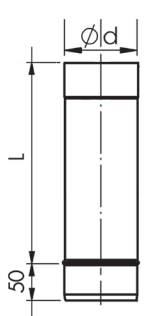
Rovný díl pro sání	Ød	ØD	Kód	Cena [Kč / ks]	Cena [€ / ks]	Ød1	Ød2	ØD2	L (mm)	Hmotnost: [kg / ks]
	80	-	IVTRL008	325,-	12,75	-	-	-	200	0,25
	100	-	IVTRL010	364,-	14,27	-	-	-	200	0,32
	120	-	IVTRL012	384,-	15,06	-	-	-	200	0,38
	-	-	-	-	-	-	-	-	-	-
	-	-	-	-	-	-	-	-	-	-
	-	-	-	-	-	-	-	-	-	-
	-	-	-	-	-	-	-	-	-	-
	-	-	-	-	-	-	-	-	-	-
	80	-	IVTRL508	510,-	20,00	-	-	-	450	0,51
	100	-	IVTRL510	589,-	23,10	-	-	-	450	0,63
	120	-	IVTRL512	629,-	24,67	-	-	-	450	0,76

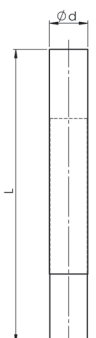
Nastavitelný díl pro sání	Ød	ØD	Kód	Cena [Kč / ks]	Cena [€ / ks]	Ød1	Ød2	ØD2	L (mm)	Hmotnost: [kg / ks]
	80	-	IVTRT508	846,-	33,18	-	-	-	445-680	0,74
	100	-	IVTRT510	978,-	38,35	-	-	-	445-680	0,94
	120	-	IVTRT512	1 071,-	42,00	-	-	-	445-680	1,11
	-	-	-	-	-	-	-	-	-	-
	-	-	-	-	-	-	-	-	-	-
	-	-	-	-	-	-	-	-	-	-
	-	-	-	-	-	-	-	-	-	-
	80	-	IVTRT108	1 329,-	52,12	-	-	-	680-1150	1,22
	100	-	IVTRT110	1 567,-	61,45	-	-	-	680-1150	1,52
	120	-	IVTRT112	1 799,-	70,55	-	-	-	680-1150	1,82
	-	-	-	-	-	-	-	-	-	-

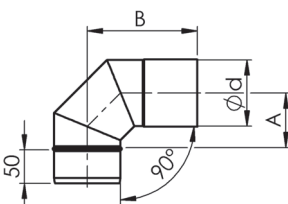
Koleno 90° pro sání	Ød	ØD	Kód	Cena [Kč / ks]	Cena [€ / ks]	Ød1	Ød2	A (mm)	B (mm)	Hmotnost: [kg / ks]
	80	-	IVTBL908	761,-	29,84	-	-	80	154	0,28
	100	-	IVTBL910	906,-	35,53	-	-	90	164	0,38
	120	-	IVTBL912	1 038,-	40,71	-	-	100	174	0,48
	-	-	-	-	-	-	-	-	-	-
	-	-	-	-	-	-	-	-	-	-
	-	-	-	-	-	-	-	-	-	-
	-	-	-	-	-	-	-	-	-	-
	-	-	-	-	-	-	-	-	-	-
	-	-	-	-	-	-	-	-	-	-
	-	-	-	-	-	-	-	-	-	-
	-	-	-	-	-	-	-	-	-	-

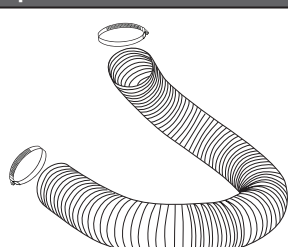
Flexibilní trubka AL pro sání se sponami 1000mm	Ød	ØD	Kód	Cena [Kč / ks]	Cena [€ / ks]	Ød1	Ød2	ØD2	A (mm)	Hmotnost: [kg / ks]
	80	-	IVTRF108	120,-	4,71	-	-	-	-	0,66
	100	-	IVTRF110	134,-	5,25	-	-	-	-	0,82
	120	-	IVTRF112	232,-	9,10	-	-	-	-	0,98
	-	-	-	-	-	-	-	-	-	-
	-	-	-	-	-	-	-	-	-	-
	-	-	-	-	-	-	-	-	-	-
	-	-	-	-	-	-	-	-	-	-
	-	-	-	-	-	-	-	-	-	-
	-	-	-	-	-	-	-	-	-	-
	-	-	-	-	-	-	-	-	-	-
	-	-	-	-	-	-	-	-	-	-

**Pozn.:**  
Dodací lhůta do 15 pracovních dnů.





**DK**

Koncentrický nerezový spalinový systém, odolný proti vlhkosti, pro přetlakový provoz.

**Tloušťka stěny:**

0,5 mm DN ≤ 200 mm

0,6 mm DN ≥ 250 mm

**Tloušťka pláště:**

0,5 mm DN ≤ 300 mm

0,6 mm DN ≥ 350 mm

**Vlastnosti systému:**

- pro olej a plyn
- odolný proti vlhkosti
- přetlakový provoz
- pro spotřebiče nezávislé na vzduchu v místnosti
- včetně těsnění
- rychlá, jednoduchá a bezpečná montáž

Koncentrický nerezový spalinový systém **ALMEVA Double DK** je vhodný pro odvod spalin od plynových a olejových spotřebičů nezávislých na vzduchu v místnosti, pracujících v přetlakovém režimu a je určen pro mokrý provoz. Je vyroben z ušlechtilé oceli třídy 1.4404 / 316L.

**Pozn.:**

Zvýrazněné položky v tabulkách jsou skladem.  
Ostatní s dodací lhůtou do 15 pracovních dnů.

Technická data pro **ALMEVA Double DK:****Třída nerezové oceli: 1.4404 / 316L****Zatřídění dle EN 14989 - 2:**

DK | EN 14989-2 T200 P1 W Vm L50 (050, 060) O00

# KONCENTRICKÝ NEREZOVÝ SYSTÉM

## DN 80/125 – 400/600 mm

**DK**  
Nerez / nerez

Kondenzát. jímka s odtok. dolů	Ød	ØD	Kód	Cena [Kč / ks]	Cena [€ / ks]	A (mm)	B (mm)	C (mm)	D (mm)	Hmotnost: [kg / ks]
	80	125	IVKMAS080125	1 222,-	47,92	65	-	-	-	0,25
	100	150	IVKMAS100150	1 309,-	51,33	65	-	-	-	0,32
	130	200	IVKMAS130200	1 494,-	58,59	65	-	-	-	0,46
	150	230	IVKMAS150230	1 647,-	64,59	65	-	-	-	0,56
	180	250	IVKMAS180250	1 752,-	68,71	65	-	-	-	0,64
	200	300	IVKMAS200300	1 956,-	76,71	65	-	-	-	0,82
	250	400	IVKMAS250400	2 670,-	104,71	65	-	-	-	1,48
	300	450	IVKMAS300450	3 138,-	123,06	65	-	-	-	1,80
	350	550	IVKMAS350550	3 739,-	146,63	65	-	-	-	2,44
	400	600	IVKMAS400600	4 128,-	161,88	65	-	-	-	2,83
Dno s odvod. kondenz. - dolů	Ød	ØD	Kód	Cena [Kč / ks]	Cena [€ / ks]	A (mm)	B (mm)	C (mm)	D (mm)	Hmotnost: [kg / ks]
	80	125	IVKFAS080125	5 404,-	211,92	-	230	-	-	6,00
	100	150	IVKFAS100150	5 780,-	226,67	-	250	-	-	6,90
	130	200	IVKFAS130200	6 606,-	259,06	-	300	-	-	8,10
	150	230	IVKFAS150230	7 134,-	279,76	-	330	-	-	9,10
	180	250	IVKFAS180250	7 550,-	296,08	-	350	-	-	9,70
	200	300	IVKFAS200300	8 442,-	331,06	-	400	-	-	11,30
	250	400	IVKFAS250400	13 513,-	529,92	-	500	-	-	19,50
	300	450	IVKFAS300450	17 259,-	676,82	-	550	-	-	21,90
	350	550	IVKFAS350550	20 415,-	800,59	-	650	-	-	33,30
	400	600	IVKFAS400600	22 277,-	873,61	-	700	-	-	36,60
Vynášecí díl	Ød	ØD	Kód	Cena [Kč / ks]	Cena [€ / ks]	A (mm)	B (mm)	C (mm)	D (mm)	Hmotnost: [kg / ks]
	80	125	IVKZSU080125	2 591,-	101,61	230	-	-	-	1,75
	100	150	IVKZSU100150	2 880,-	112,94	250	-	-	-	1,90
	130	200	IVKZSU130200	3 495,-	137,06	300	-	-	-	2,25
	150	230	IVKZSU150230	3 931,-	154,16	330	-	-	-	2,66
	180	250	IVKZSU180250	4 300,-	168,63	350	-	-	-	2,81
	200	300	IVKZSU200300	5 049,-	198,00	400	-	-	-	2,73
	250	400	IVKZSU250400	9 136,-	358,27	500	-	-	-	6,49
	300	450	IVKZSU300450	11 829,-	463,88	550	-	-	-	10,61
	350	550	IVKZSU350550	14 881,-	583,57	650	-	-	-	14,34
	400	600	IVKZSU400600	16 815,-	659,41	700	-	-	-	16,42
Kontrolní díl	Ød	ØD	Kód	Cena [Kč / ks]	Cena [€ / ks]	L (mm)	B (mm)	C (mm)	D (mm)	Hmotnost: [kg / ks]
	80	125	IVKRTN080125	2 478,-	97,18	315	-	-	-	1,75
	100	150	IVKRTN100150	2 802,-	109,88	340	-	-	-	2,25
	130	200	IVKRTN130200	3 542,-	138,90	390	-	-	-	3,29
	150	230	IVKRTN150230	4 056,-	159,06	420	-	-	-	4,03
	180	250	IVKRTN180250	4 631,-	181,61	440	-	-	-	4,72
	200	300	IVKRTN200300	5 582,-	218,90	490	-	-	-	6,02
	250	400	IVKRTN250400	9 294,-	364,47	590	-	-	-	10,08
	300	450	IVKRTN300450	11 012,-	431,84	640	-	-	-	12,49
	350	550	IVKRTN350550	13 745,-	539,02	740	-	-	-	17,06
	400	600	IVKRTN400600	15 846,-	621,41	790	-	-	-	20,11
Sopouch 85°	Ød	ØD	Kód	Cena [Kč / ks]	Cena [€ / ks]	L (mm)	Z (mm)	X (mm)	D (mm)	Hmotnost: [kg / ks]
	80	125	IVKTE8080125	2 115,-	82,94	345	213	183	-	1,69
	100	150	IVKTE8100150	2 373,-	93,06	370	225	195	-	2,16
	130	200	IVKTE8130200	3 012,-	118,12	420	250	220	-	3,13
	150	230	IVKTE8150230	3 455,-	135,49	450	265	235	-	3,81
	180	250	IVKTE8180250	3 970,-	155,69	470	275	245	-	4,45
	200	300	IVKTE8200300	4 790,-	187,84	520	300	270	-	5,64
	250	400	IVKTE8250400	7 899,-	309,76	620	350	320	-	9,20
	300	450	IVKTE8300450	9 380,-	367,84	670	375	345	-	11,39
	350	550	IVKTE8350550	11 638,-	456,39	720	400	370	-	15,45
	400	600	IVKTE8400600	13 468,-	528,16	820	450	420	-	18,21

**Pozn.:**

Zvýrazněné položky v tabulkách jsou skladem. Ostatní s dodací lhůtou do 15 pracovních dnů.

Rovný díl 450mm s 85° odbočkou 60/100	Ød	ØD	Kód	Cena [Kč / ks]	Cena [€ / ks]	L (mm)	Z (mm)	X (mm)	D (mm)	Hmotnost: [kg / ks]
	80	125	IVKTR6080125	2 135,-	83,73	450	167	294	-	1,59
	100	150	IVKTR6100150	2 373,-	93,06	450	175	300	-	1,89
	130	200	IVKTR6130200	2 716,-	106,51	450	200	300	-	2,43
	150	230	IVKTR6150230	2 954,-	115,84	450	215	300	-	2,77
	180	250	IVKTR6180250	3 178,-	124,63	450	225	300	-	3,09
	200	300	IVKTR6200300	3 489,-	136,82	450	225	300	-	3,20
	250	400	IVKTR6250400	4 321,-	169,45	450	275	300	-	4,57
	300	450	IVKTR6300450	4 750,-	186,27	450	300	300	-	5,82
	350	550	IVKTR6350550	5 411,-	212,20	450	375	300	-	7,48
	400	600	IVKTR6400600	5 827,-	228,51	450	400	300	-	8,26

Rovný díl 450mm s 85° odbočkou 80/125	Ød	ØD	Kód	Cena [Kč / ks]	Cena [€ / ks]	L (mm)	Z (mm)	X (mm)	D (mm)	Hmotnost: [kg / ks]
	-	-	-	-	-	-	-	-	-	-
	100	150	IVKTR8100150	2 373,-	93,06	450	175	287	-	1,95
	130	200	IVKTR8130200	2 734,-	107,22	450	200	287	-	2,50
	150	230	IVKTR8150230	2 993,-	117,37	450	215	287	-	2,84
	180	250	IVKTR8180250	3 243,-	127,18	450	225	287	-	3,16
	200	300	IVKTR8200300	3 489,-	136,82	450	225	287	-	3,27
	250	400	IVKTR8250400	4 321,-	169,45	450	275	287	-	4,65
	300	450	IVKTR8300450	4 750,-	186,27	450	300	287	-	5,91
	350	550	IVKTR8350550	5 411,-	212,20	450	375	287	-	7,58
	400	600	IVKTR8400600	5 827,-	228,51	450	400	287	-	8,37

Rovný díl 450mm s 85° odbočkou 100/150	Ød	ØD	Kód	Cena [Kč / ks]	Cena [€ / ks]	L (mm)	Z (mm)	X (mm)	D (mm)	Hmotnost: [kg / ks]
	-	-	-	-	-	-	-	-	-	-
	-	-	-	-	-	-	-	-	-	-
	130	200	IVKTR1130200	2 836,-	111,22	450	200	275	-	2,57
	150	230	IVKTR1150230	3 078,-	120,71	450	215	275	-	2,91
	180	250	IVKTR1180250	3 331,-	130,63	450	225	275	-	3,22
	200	300	IVKTR1200300	3 607,-	141,45	450	225	275	-	3,33
	250	400	IVKTR1250400	4 420,-	173,33	450	275	275	-	4,73
	300	450	IVKTR1300450	4 849,-	190,16	450	300	275	-	5,99
	350	550	IVKTR1350550	5 497,-	215,57	450	375	275	-	7,69
	400	600	IVKTR1400600	5 926,-	232,39	450	400	275	-	8,47

Rovný díl 950mm	Ød	ØD	Kód	Cena [Kč / ks]	Cena [€ / ks]	A (mm)	B (mm)	C (mm)	D (mm)	Hmotnost: [kg / ks]
	80	125	IVKRM1080125	1 732,-	67,92	-	-	-	-	2,58
	100	150	IVKRM1100150	1 970,-	77,25	-	-	-	-	3,14
	130	200	IVKRM1130200	2 399,-	94,08	-	-	-	-	4,15
	150	230	IVKRM1150230	2 696,-	105,73	-	-	-	-	4,78
	180	250	IVKRM1180250	3 012,-	118,12	-	-	-	-	5,40
	200	300	IVKRM1200300	3 429,-	134,47	-	-	-	-	6,28
	250	400	IVKRM1250400	5 181,-	203,18	-	-	-	-	8,80
	300	450	IVKRM1300450	5 907,-	231,65	-	-	-	-	10,18
	350	550	IVKRM1350550	6 836,-	268,08	-	-	-	-	12,19
	400	600	IVKRM1400600	7 650,-	300,00	-	-	-	-	13,57

Rovný díl 450mm	Ød	ØD	Kód	Cena [Kč / ks]	Cena [€ / ks]	A (mm)	B (mm)	C (mm)	D (mm)	Hmotnost: [kg / ks]
	80	125	IVKRM5080125	1 185,-	46,47	-	-	-	-	1,29
	100	150	IVKRM5100150	1 277,-	50,08	-	-	-	-	1,57
	130	200	IVKRM5130200	1 488,-	58,35	-	-	-	-	2,07
	150	230	IVKRM5150230	1 647,-	64,59	-	-	-	-	2,39
	180	250	IVKRM5180250	1 824,-	71,53	-	-	-	-	2,70
	200	300	IVKRM5200300	2 056,-	80,63	-	-	-	-	3,14
	250	400	IVKRM5250400	3 066,-	120,24	-	-	-	-	4,40
	300	450	IVKRM5300450	3 463,-	135,80	-	-	-	-	5,09
	350	550	IVKRM5350550	4 223,-	165,61	-	-	-	-	6,09
	400	600	IVKRM5400600	4 737,-	185,76	-	-	-	-	6,79

**Pozn.:**

Zvýrazněné položky v tabulkách jsou skladem. Ostatní s dodací lhůtou do 15 pracovních dnů.

# KONCENTRICKÝ NEREZOVÝ SYSTÉM

## DN 80/125 – 400/600 mm

Rovný díl 200mm	Ød	ØD	Kód	Cena [Kč / ks]	Cena [€ / ks]	A (mm)	B (mm)	C (mm)	D (mm)	Hmotnost: [kg / ks]
	80	125	IVKRM0080125	900,-	35,29	-	-	-	-	0,64
	100	150	IVKRM0100150	926,-	36,31	-	-	-	-	0,79
	130	200	IVKRM0130200	1 019,-	39,96	-	-	-	-	1,04
	150	230	IVKRM0150230	1 110,-	43,53	-	-	-	-	1,19
	180	250	IVKRM0180250	1 217,-	47,73	-	-	-	-	1,35
	200	300	IVKRM0200300	1 355,-	53,14	-	-	-	-	1,57
	250	400	IVKRM0250400	1 996,-	78,27	-	-	-	-	2,20
	300	450	IVKRM0300450	2 220,-	87,06	-	-	-	-	2,54
	350	550	IVKRM0350550	2 737,-	107,33	-	-	-	-	3,05
	400	600	IVKRM0400600	3 078,-	120,71	-	-	-	-	3,39
Koleno 30°	Ød	ØD	Kód	Cena [Kč / ks]	Cena [€ / ks]	A (mm)	B (mm)	C (mm)	D (mm)	Hmotnost: [kg / ks]
	80	125	IVKSB3080125	1 085,-	42,55	56	106	-	-	0,76
	100	150	IVKSB3100150	1 190,-	46,67	60	110	-	-	0,96
	130	200	IVKSB3130200	1 303,-	51,10	67	117	-	-	1,36
	150	230	IVKSB3150230	1 488,-	58,35	71	121	-	-	1,64
	180	250	IVKSB3180250	1 725,-	67,65	74	124	-	-	1,91
	200	300	IVKSB3200300	2 115,-	82,94	80	130	-	-	2,38
	250	400	IVKSB3250400	3 489,-	136,82	94	144	-	-	3,79
	300	450	IVKSB3300450	4 063,-	159,33	100	150	-	-	4,65
	350	550	IVKSB3350550	4 908,-	192,47	115	165	-	-	6,22
	400	600	IVKSB3400600	5 667,-	222,24	120	170	-	-	7,28
Koleno 45°	Ød	ØD	Kód	Cena [Kč / ks]	Cena [€ / ks]	A (mm)	B (mm)	C (mm)	D (mm)	Hmotnost: [kg / ks]
	80	125	IVKSB4080125	1 251,-	49,06	175	93	-	-	0,84
	100	150	IVKSB4100150	1 349,-	52,90	189	99	-	-	1,06
	130	200	IVKSB4130200	1 506,-	59,06	220	112	-	-	1,49
	150	230	IVKSB4150230	1 719,-	67,41	231	116	-	-	1,89
	180	250	IVKSB4180250	1 988,-	77,96	238	119	-	-	2,19
	200	300	IVKSB4200300	2 418,-	94,82	256	127	-	-	2,71
	250	400	IVKSB4250400	4 016,-	157,49	291	141	-	-	4,25
	300	450	IVKSB4300450	4 685,-	183,73	309	149	-	-	5,17
	350	550	IVKSB4350550	5 649,-	221,53	344	163	-	-	6,84
	400	600	IVKSB4400600	6 493,-	254,63	362	171	-	-	7,97
Koleno 85°	Ød	ØD	Kód	Cena [Kč / ks]	Cena [€ / ks]	A (mm)	B (mm)	C (mm)	D (mm)	Hmotnost: [kg / ks]
	80	125	IVKSB8080125	1 474,-	57,80	143	193	-	-	1,03
	100	150	IVKSB8100150	1 652,-	64,78	173	204	-	-	1,31
	130	200	IVKSB8130200	1 831,-	71,80	219	246	-	-	1,88
	150	230	IVKSB8150230	2 115,-	82,94	234	260	-	-	2,47
	180	250	IVKSB8180250	2 444,-	95,84	244	269	-	-	2,88
	200	300	IVKSB8200300	2 986,-	117,10	269	292	-	-	3,60
	250	400	IVKSB8250400	5 101,-	200,04	319	337	-	-	4,75
	300	450	IVKSB8300450	6 018,-	236,00	344	360	-	-	7,06
	350	550	IVKSB8350550	7 431,-	291,41	394	406	-	-	9,46
	400	600	IVKSB8400600	8 580,-	336,47	418	428	-	-	11,08
Hlavice s manžetou proti zatékání	Ød	ØD	Kód	Cena [Kč / ks]	Cena [€ / ks]	L (mm)	B (mm)	C (mm)	D (mm)	Hmotnost: [kg / ks]
	80	125	IVKKPU080125	926,-	36,31	150	-	-	-	0,53
	100	150	IVKKPU100150	1 130,-	44,31	160	-	-	-	0,65
	130	200	IVKKPU130200	1 230,-	48,24	160	-	-	-	0,91
	150	230	IVKKPU150230	1 374,-	53,88	160	-	-	-	1,05
	180	250	IVKKPU180250	1 559,-	61,14	160	-	-	-	1,22
	200	300	IVKKPU200300	1 799,-	70,55	170	-	-	-	1,43
	250	400	IVKKPU250400	2 657,-	104,20	180	-	-	-	2,57
	300	450	IVKKPU300450	3 133,-	122,86	180	-	-	-	3,08
	350	550	IVKKPU350550	3 912,-	153,41	220	-	-	-	4,02
	400	600	IVKKPU400600	4 539,-	178,00	220	-	-	-	4,61

### Poznámka:

Konzole, stěnové objímky, průchodky a další prvky jsou obsaženy v systému **DW 25** a jsou kompatibilní.

### Pozn.:

Zvýrazněné položky v tabulkách jsou skladem. Ostatní s dodací lhůtou do 15 pracovních dnů.

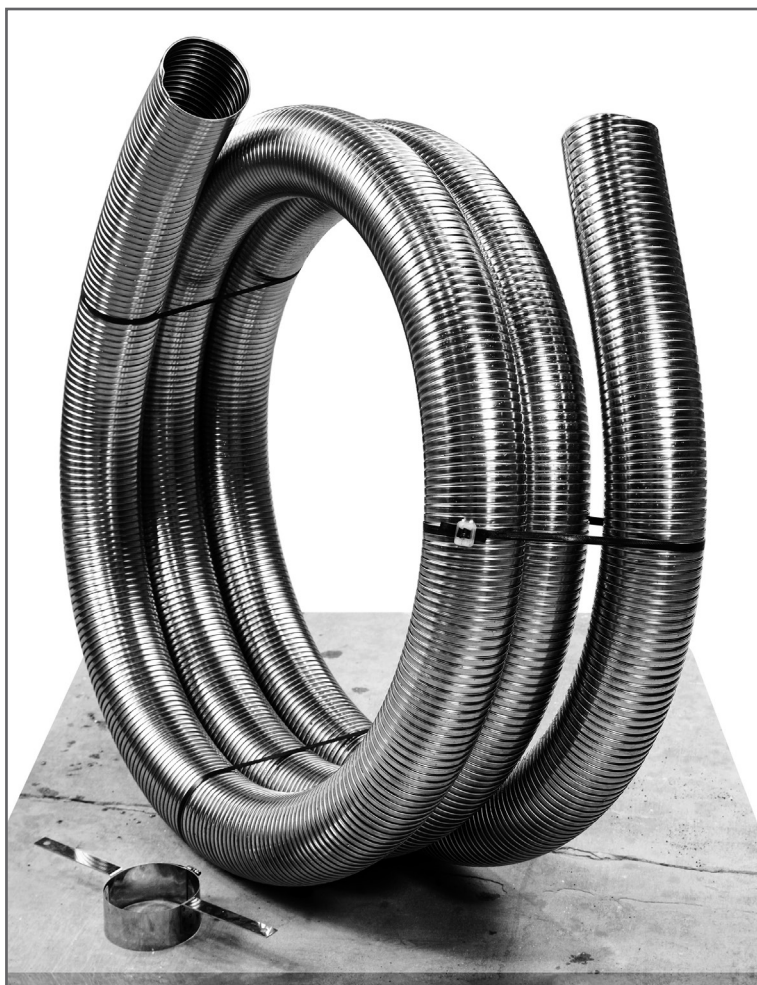

## INOX FLEX FB

Ohebný nerezový komínový systém, s tloušťkou stěny 0,4 mm, pro uhýbané komínové průduchy.

### Tloušťka stěny:

0,4 mm - hadice

0,6 mm - tvarovky

### Vlastnosti systému:

- pro pevná paliva
- pro uhýbané komíny
- provoz s přirozeným tahem
- kompatibilní se systémem EW
- rychlá, jednoduchá a bezpečná montáž

Nerezový ohebný komínový systém **ALMEVA INOX FLEX FB** je vhodný pro odvod spalin od všech typů spotřebičů na pevná paliva, pracujících v podtlakovém režimu (s přirozeným tahem) a je určen pro suchý provoz. Je vyroben z ušlechtilé oceli třídy 1.4404 / 316L.

### Pozn.:

Pro objednání hadice je minimální délka 3 m.  
Dodací lhůta do 10 pracovních dnů.

### Technická data pro ALMEVA INOX FLEX FB:

**Třída nerezové oceli: 1.4404 / 316L**

**Zatřídění dle EN 1856 - 2:**

INOX FLEX FB	EN 1856-2 T450 N1 D3 Vm L50040 G50								
světlý Ø (mm)	120	130	140	150	160	170	180	190	200
vnější Ø (mm)	128	138	148	158	168	178	188	198	208

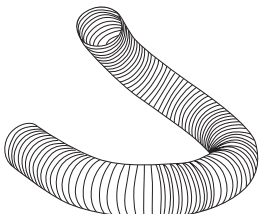
Flexibilní trubka FB	Ød	Kód	Cena [Kč / bm]	Cena [€ / bm]	Minimální objednáací délka (mm)	Maximální objednáací délka (mm)	Hmotnost: [kg / ks]
	120	IFRF12	1 525,-	59,80	3 000	20 000	1,85
	130	IFRF13	1 576,-	61,80	3 000	20 000	2,00
	140	IFRF14	1 615,-	63,33	3 000	20 000	2,29
	150	IFRF15	1 701,-	66,71	3 000	20 000	2,46
	160	IFRF16	1 798,-	70,51	3 000	20 000	2,53
	170	IFRF17	1 945,-	76,27	3 000	20 000	2,62
	180	IFRF18	2 022,-	79,29	3 000	20 000	2,80
	190	IFRF19	2 189,-	85,84	3 000	20 000	3,00
	200	IFRF20	2 315,-	90,78	3 000	20 000	3,25

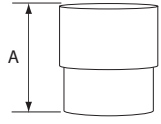
Přechodka pevná / flex FB a spojka flex FB	Ød	Kód	Cena [Kč / ks]	Cena [€ / ks]	A (mm)	B (mm)	C (mm)	D (mm)	Hmotnost: [kg / ks]
	120	IFAE12	302,-	11,84	140	-	-	-	0,40
	130	IFAE13	333,-	13,06	140	-	-	-	0,46
	140	IFAE14	348,-	13,65	140	-	-	-	0,48
	150	IFAE15	355,-	13,92	140	-	-	-	0,52
	160	IFAE16	383,-	15,02	140	-	-	-	0,54
	170	IFAE17	399,-	15,65	140	-	-	-	0,58
	180	IFAE18	412,-	16,16	140	-	-	-	0,62
	190	IFAE19	429,-	16,82	140	-	-	-	0,65
	200	IFAE20	447,-	17,53	140	-	-	-	0,69

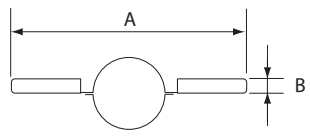
Kotvící spona	Ød	Kód	Cena [Kč / ks]	Cena [€ / ks]	A (mm)	B (mm)	C (mm)	D (mm)	Hmotnost: [kg / ks]
	120	IGSI12	388,-	15,22	360	30	-	-	0,36
	130	IGSI13	421,-	16,51	370	30	-	-	0,45
	140	IGSI14	447,-	17,53	380	30	-	-	0,49
	150	IGSI15	478,-	18,75	390	30	-	-	0,53
	160	IGSI16	502,-	19,69	400	30	-	-	0,56
	170	IGSI17	515,-	20,20	410	30	-	-	0,58
	180	IGSI18	528,-	20,71	420	30	-	-	0,60
	190	IGSI19	544,-	21,33	440	30	-	-	0,62
	200	IGSI20	561,-	22,00	440	30	-	-	0,64

**Pozn.:**  
Dodací lhůta do 10 pracovních dnů.



## INOX FLEX G

Ohebný nerezový komínový systém, s tloušťkou stěny 0,1 mm, pro uhýbané komínové průduchy.

### Tloušťka stěny:

0,1 mm - hadice

0,6 mm - tvarovky

### Vlastnosti systému:

- pro olej a plyn
- odolný proti vlhkosti
- pro uhýbané komíny
- vhodný pro podtlakový i přetlakový provoz
- včetně těsnění
- rychlá, jednoduchá a bezpečná montáž

Nerezový ohebný komínový systém **ALMEVA INOX FLEX G** je vhodný pro odvod spalin od všech typů spotřebičů na plynná paliva, pracujících v podtlakovém i přetlakovém režimu (zejména atmosférické spotřebiče typu „TURBO“). Systém je určen jak pro suchý tak i mokry provoz a je vyroben z ušlechtilé oceli třídy 1.4404.

### Pozn.:

Zvýrazněné položky v tabulkách jsou skladem v délkách 10, 15, 20, 25, 30m.

Ostatní položky a individuální délky flexibilní trubky s dodací lhůtou do 10 pracovních dnů.

### Technická data pro ALMEVA INOX FLEX G:

**Třída nerezové oceli: 1.4404 / 316L**

**Zatřídění dle EN 1856 - 2:**

INOX FLEX G	EN 1856-2 T600 N1 W V2 L50010 G50													
INOX FLEX G	EN 1856-2 T200 N1 W V2 L50010 O50													
INOX FLEX G	EN 1856-2 T200 P1 W V2 L50010 O50													
světlý Ø (mm)	80	100	110	120	125	130	140	150	160	180	200	220	250	300
vnější Ø (mm)	87	107	117	127	132	137	147	157	167	187	207	227	257	307

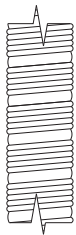

Flexibilní trubka G	Ød	Kód	Cena [Kč / bm]	Cena [€ / bm]	Minimální objednáč. délka (mm)	Maximální objednáč. délka (mm)	Hmotnost: [kg / ks]
	80	IGRF80	392,-	15,37	3 000	30 000	0,48
	100	IGRF10	484,-	18,98	3 000	30 000	0,50
	110	IGRF11	537,-	21,06	3 000	30 000	0,52
	120	IGRF12	586,-	22,98	3 000	30 000	0,58
	125	IGRF1V	608,-	23,84	3 000	30 000	0,62
	130	IGRF13	634,-	24,86	3 000	30 000	0,70
	140	IGRF14	682,-	26,75	3 000	30 000	0,78
	150	IGRF15	733,-	28,75	3 000	30 000	0,82
	160	IGRF16	779,-	30,55	3 000	30 000	0,87
	180	IGRF18	880,-	34,51	3 000	25 000	0,95
	200	IGRF20	979,-	38,39	3 000	20 000	1,10
	220	IGRF22	1 202,-	47,14	3 000	15 000	1,25
	250	IGRF25	1 226,-	48,08	3 000	15 000	1,45
	300	IGRF30	1 468,-	57,57	3 000	10 000	1,70

Flexibilní trubka G – balení	Ød	Kód	Cena [Kč / ks]	Cena [€ / ks]	Délka balení (mm)			Hmotnost: [kg / ks]
	80	IGRF81	3 910,-	153,33	10 000	-	-	4,80
	80	IGRF85	5 868,-	230,12	15 000	-	-	7,20
	80	IGRF82	7 821,-	306,71	20 000	-	-	9,60
	80	IGRF8V	9 777,-	383,41	25 000	-	-	12,00
	80	IGRF83	11 253,-	441,29	30 000	-	-	14,00

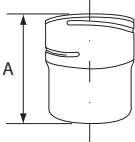
Přechodka pevná / flex	Ød	Kód	Cena [Kč / ks]	Cena [€ / ks]	A (mm)	B (mm)	C (mm)	D (mm)	Hmotnost: [kg / ks]
	80	IGAE80	454,-	17,80	145	-	-	-	0,17
	100	IGAE10	467,-	18,31	145	-	-	-	0,22
	110	IGAE11	513,-	20,12	145	-	-	-	0,27
	120	IGAE12	553,-	21,69	145	-	-	-	0,35
	125	IGAE1V	588,-	23,06	145	-	-	-	0,39
	130	IGAE13	623,-	24,43	145	-	-	-	0,27
	140	IGAE14	665,-	26,08	145	-	-	-	0,46
	150	IGAE15	770,-	30,20	145	-	-	-	0,53
	160	IGAE16	795,-	31,18	145	-	-	-	0,60
	180	IGAE18	850,-	33,33	145	-	-	-	0,68
	200	IGAE20	927,-	36,35	145	-	-	-	0,75
	220	IGAE22	1 008,-	39,53	145	-	-	-	0,84
	250	IGAE25	1 153,-	45,22	145	-	-	-	0,93
	300	IGAE30	1 294,-	50,75	145	-	-	-	1,02

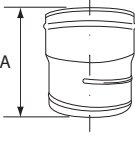
Přechodka flex / pevná s těsněním	Ød	Kód	Cena [Kč / ks]	Cena [€ / ks]	A (mm)	B (mm)	C (mm)	D (mm)	Hmotnost: [kg / ks]
	80	IGAD80	630,-	24,71	145	-	-	-	0,17
	100	IGAD10	674,-	26,43	145	-	-	-	0,23
	110	IGAD11	731,-	28,67	145	-	-	-	0,30
	120	IGAD12	770,-	30,20	145	-	-	-	0,38
	125	IGAD1V	812,-	31,84	145	-	-	-	0,46
	130	IGAD13	839,-	32,90	145	-	-	-	0,54
	140	IGAD14	920,-	36,08	145	-	-	-	0,60
	150	IGAD15	964,-	37,80	145	-	-	-	0,67
	160	IGAD16	1 028,-	40,31	145	-	-	-	0,75
	180	IGAD18	1 096,-	42,98	145	-	-	-	0,83
	200	IGAD20	1 160,-	45,49	145	-	-	-	0,90
	220	IGAD22	1 230,-	48,24	145	-	-	-	0,97
	250	IGAD25	1 397,-	54,78	145	-	-	-	0,99
	300	IGAD30	1 622,-	63,61	145	-	-	-	1,08

**Pozn.:** Zvýrazněné položky v tabulkách jsou skladem. Ostatní s dodací lhůtou do 10 pracovních dnů.

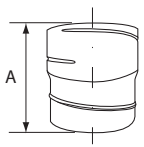
Spojka flex / flex	Ød	Kód	Cena [Kč / ks]	Cena [€ / ks]	A (mm)	B (mm)	C (mm)	D (mm)	Hmotnost: [kg / ks]
	80	IGKU80	603,-	23,65	145	-	-	-	0,17
	100	IGKU10	674,-	26,43	145	-	-	-	0,21
	110	IGKU11	731,-	28,67	145	-	-	-	0,27
	120	IGKU12	770,-	30,20	145	-	-	-	0,35
	125	IGKU1V	812,-	31,84	145	-	-	-	0,39
	130	IGKU13	839,-	32,90	145	-	-	-	0,44
	140	IGKU14	894,-	35,06	145	-	-	-	0,54
	150	IGKU15	946,-	37,10	145	-	-	-	0,61
	160	IGKU16	973,-	38,16	145	-	-	-	0,67
	180	IGKU18	1 034,-	40,55	145	-	-	-	0,73
	200	IGKU20	1 094,-	42,90	145	-	-	-	0,85
	220	IGKU22	1 138,-	44,63	145	-	-	-	0,92
	250	IGKU25	1 228,-	48,16	145	-	-	-	0,98
	300	IGKU30	1 327,-	52,04	145	-	-	-	1,15

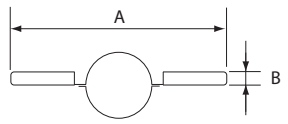
Kotvící spona	Ød	Kód	Cena [Kč / ks]	Cena [€ / ks]	A (mm)	B (mm)	C (mm)	D (mm)	Hmotnost: [kg / ks]
	80	IGSI80	328,-	12,86	320	30	-	-	0,21
	100	IGSI10	359,-	14,08	340	30	-	-	0,25
	110	IGSI11	368,-	14,43	350	30	-	-	0,30
	120	IGSI12	388,-	15,22	360	30	-	-	0,36
	125	IGSI1V	405,-	15,88	365	30	-	-	0,42
	130	IGSI13	421,-	16,51	370	30	-	-	0,45
	140	IGSI14	447,-	17,53	380	30	-	-	0,49
	150	IGSI15	478,-	18,75	390	30	-	-	0,53
	160	IGSI16	502,-	19,69	400	30	-	-	0,56
	170	IGSI17	515,-	20,20	410	30	-	-	0,58
	180	IGSI18	528,-	20,71	420	30	-	-	0,60
	190	IGSI19	544,-	21,33	440	30	-	-	0,62
	200	IGSI20	561,-	22,00	440	30	-	-	0,64
	220	IGSI22	718,-	28,16	460	30	-	-	0,68
250	IGSI25	832,-	32,63	490	30	-	-	0,72	
300	IGSI30	940,-	36,86	540	30	-	-	0,77	

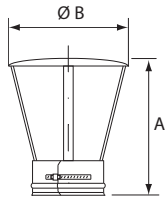
Kryt proti dešti	Ød	Kód	Cena [Kč / ks]	Cena [€ / ks]	A (mm)	B (mm)	C (mm)	D (mm)	Hmotnost: [kg / ks]
	80	IGMK80	555,-	21,76	160	110	-	-	0,17
	100	IGMK10	612,-	24,00	200	140	-	-	0,25
	110	IGMK11	656,-	25,73	220	150	-	-	0,27
	120	IGMK12	674,-	26,43	240	160	-	-	0,40
	125	IGMK1V	687,-	26,94	250	165	-	-	0,45
	130	IGMK13	742,-	29,10	260	170	-	-	0,35
	140	IGMK14	808,-	31,69	280	180	-	-	0,50
	150	IGMK15	845,-	33,14	300	190	-	-	0,58
	160	IGMK16	940,-	36,86	320	200	-	-	0,67
	180	IGMK18	1 026,-	40,24	360	220	-	-	0,65
	200	IGMK20	1 140,-	44,71	400	240	-	-	0,80
	220	IGMK22	1 353,-	53,06	440	260	-	-	0,98
	250	IGMK25	1 675,-	65,69	470	290	-	-	1,05
	300	IGMK30	2 119,-	83,10	530	340	-	-	1,30

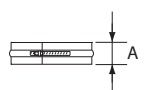
Pojistná objímka	Ød	Kód	Cena [Kč / ks]	Cena [€ / ks]	A (mm)	B (mm)	C (mm)	D (mm)	Hmotnost: [kg / ks]
	80	IGKL80	165,-	6,47	25	-	-	-	0,05
	100	IGKL10	172,-	6,75	25	-	-	-	0,06
	110	IGKL11	172,-	6,75	25	-	-	-	0,07
	120	IGKL12	176,-	6,90	25	-	-	-	0,08
	125	IGKL1V	190,-	7,45	25	-	-	-	0,09
	130	IGKL13	205,-	8,04	25	-	-	-	0,10
	140	IGKL14	218,-	8,55	25	-	-	-	0,10
	150	IGKL15	227,-	8,90	25	-	-	-	0,11
	160	IGKL16	231,-	9,06	25	-	-	-	0,12
	180	IGKL18	242,-	9,49	25	-	-	-	0,13
	200	IGKL20	247,-	9,69	25	-	-	-	0,14
	220	IGKL22	253,-	9,92	25	-	-	-	0,15
	250	IGKL25	256,-	10,04	25	-	-	-	0,17
	300	IGKL30	295,-	11,57	25	-	-	-	0,20

**Pozn.:**

Zvýrazněné položky v tabulkách jsou skladem. Ostatní s dodací lhůtou do 10 pracovních dnů.

**JEDNOVRSTVÝ NEREZOVÝ OHEBNÝ SYSTÉM**  
**DN 80 – 300 mm**

**INOX FLEX G**  
**Nerez**

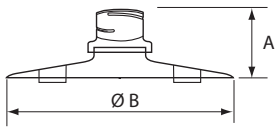
Krycí deska se závěsnou maticí	Ød	Kód	Cena [Kč / ks]	Cena [€ / ks]	A (mm)	B (mm)	C (mm)	D (mm)	Hmotnost: [kg / ks]
	80	IGSA80	731,-	28,67	120	250	-	-	0,37
	100	IGSA10	795,-	31,18	120	270	-	-	0,52
	110	IGSA11	854,-	33,49	120	280	-	-	0,67
	120	IGSA12	905,-	35,49	120	290	-	-	0,82
	125	IGSA1V	938,-	36,78	120	295	-	-	1,18
	130	IGSA13	949,-	37,22	120	300	-	-	1,38
	140	IGSA14	1 017,-	39,88	120	310	-	-	1,58
	150	IGSA15	1 081,-	42,39	120	320	-	-	1,78
	160	IGSA16	1 133,-	44,43	120	330	-	-	1,98
	180	IGSA18	1 228,-	48,16	120	350	-	-	2,14
	200	IGSA20	1 373,-	53,84	120	370	-	-	2,32
	220	IGSA22	1 507,-	59,10	120	390	-	-	2,50
	250	IGSA25	1 714,-	67,22	120	420	-	-	2,68
	300	IGSA30	2 033,-	79,73	120	470	-	-	2,86

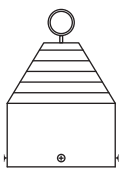
Protahovací hlava	Ød	Kód	Cena [Kč / ks]	Cena [€ / ks]	A (mm)	B (mm)	C (mm)	D (mm)	Hmotnost: [kg / ks]
	80	IGEZ80	498,-	19,53	-	-	-	-	0,16
	100	IGEZ10	506,-	19,84	-	-	-	-	0,25
	110	IGEZ11	544,-	21,33	-	-	-	-	0,27
	120	IGEZ12	590,-	23,14	-	-	-	-	0,37
	125	IGEZ1V	676,-	26,51	-	-	-	-	0,41
	130	IGEZ13	715,-	28,04	-	-	-	-	0,45
	140	IGEZ14	737,-	28,90	-	-	-	-	0,48
	150	IGEZ15	764,-	29,96	-	-	-	-	0,55
	160	IGEZ16	810,-	31,76	-	-	-	-	0,62
	180	IGEZ18	834,-	32,71	-	-	-	-	0,70
	200	IGEZ20	900,-	35,29	-	-	-	-	0,77
	220	IGEZ22	1 059,-	41,53	-	-	-	-	0,86
	250	IGEZ25	1 087,-	42,63	-	-	-	-	0,95
	300	IGEZ30	1 243,-	48,75	-	-	-	-	1,04

Pozn.:  
 Součástí hlavy není provaz

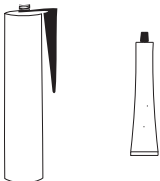
Těsnící silikon	Ød	Kód	Cena [Kč / ks]	Cena [€ / ks]	A (mm)	B (mm)	C (mm)	D (mm)	objem [ml / ks]
	-	ZUSFS0	627,-	24,59	-	-	-	-	290
	-	ZUSFS8	218,-	8,55	-	-	-	-	80
	-	-	-	-	-	-	-	-	-
	-	-	-	-	-	-	-	-	-
	-	-	-	-	-	-	-	-	-
	-	-	-	-	-	-	-	-	-
	-	-	-	-	-	-	-	-	-
	-	-	-	-	-	-	-	-	-

**Pozn.:**  
 Zvýrazněné položky v tabulkách jsou skladem. Ostatní s dodací lhůtou do 10 pracovních dnů.

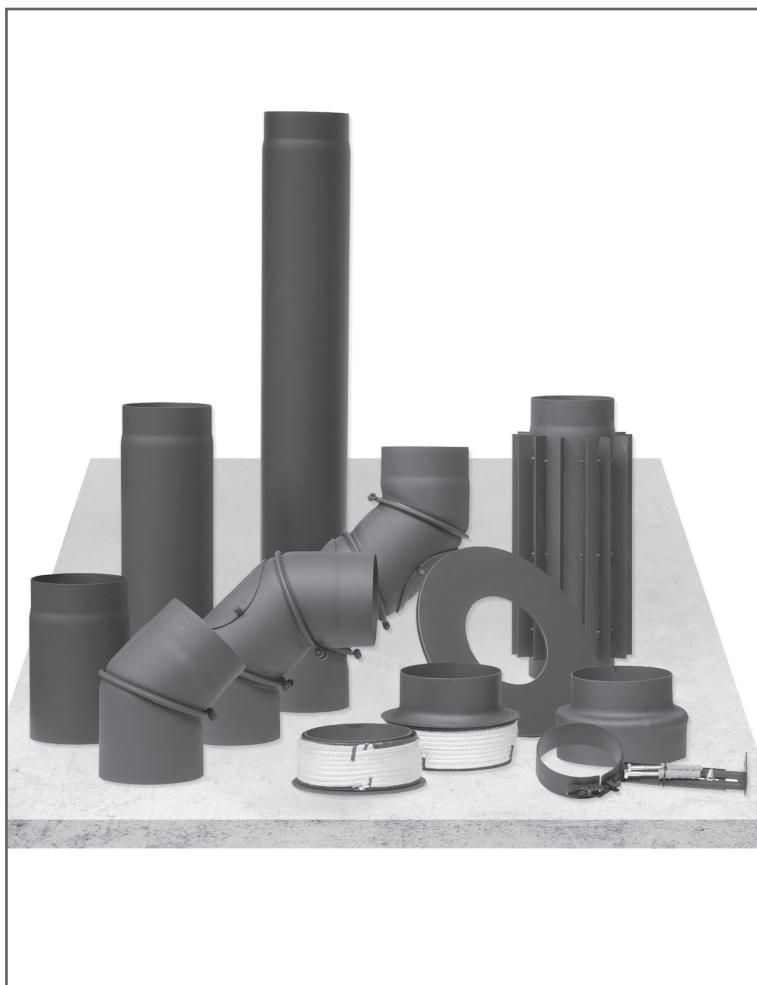

### ORM

Jednovrstvý ocelový systém, s **tloušťkou stěny 2 mm**, pro dopojení spotřebičů. Barva černá (Senotherm).

#### Vlastnosti systému:

- pro pevná paliva
- pro kouřovody
- pro podtlakový provoz
- rychlá, jednoduchá a bezpečná montáž

Ocelový pevný komínový systém **ALMEVA Easy ORM** je vhodný pro odvod spalin od všech typů spotřebičů na pevná paliva, pracujících v podtlakovém režimu (s přirozeným tahem) a je určen pro suchý provoz. Je vyroben z oceli třídy EN 10025-5/S 235 JRG 2.

#### Pozn.:

Zvýrazněné položky v tabulkách jsou skladem.  
Ostatní s dodací lhůtou do 10 pracovních dnů.

Technická data pro **ALMEVA Easy ORM**:

**Třída oceli: EN 10025-5/S 235 JRG 2**

**Zatřídění dle EN 1856 - 2:**

ORM	EN 1856-2 T400 N1 D Vm L01200 G500
-----	------------------------------------

# JEDNOVRSTVÝ OCELOVÝ SYSTÉM

## DN 120 – 200 mm

# ORM

Ocel - černá

Trubka	Ød	Kód	Cena [Kč / ks]	Cena [€ / ks]	D [mm]	b (mm)	h (mm)	H (mm)	Hmotnost: [kg / ks]
	120	IORRM12	650,-	25,50	125	-	-	1000	6,00
	130	IORRM13	665,-	26,08	135	-	-	1000	6,40
	150	IORRM15	740,-	29,02	155	-	-	1000	7,30
	160	IORRM16	810,-	31,77	165	-	-	1000	7,90
	180	IORRM18	885,-	34,71	185	-	-	1000	9,00
	200	IORRM10	955,-	37,46	205	-	-	1000	10,00
	120	IORRM52	440,-	17,26	125	-	-	500	3,00
	130	IORRM53	475,-	18,63	135	-	-	500	3,20
	150	IORRM55	485,-	19,02	155	-	-	500	3,80
	160	IORRM56	495,-	19,42	165	-	-	500	4,00
	180	IORRM58	560,-	21,97	185	-	-	500	4,40
	200	IORRM50	610,-	23,93	205	-	-	500	5,00
	120	IORRM02	320,-	12,55	125	-	-	250	1,40
	130	IORRM03	335,-	13,14	135	-	-	250	1,60
	150	IORRM05	360,-	14,12	155	-	-	250	1,80
	160	IORRM06	370,-	14,51	165	-	-	250	2,00
	180	IORRM08	410,-	16,08	185	-	-	250	2,20
	200	IORRM00	460,-	18,04	205	-	-	250	2,60

Trubka 450mm s čistícím otvorem	Ød	Kód	Cena [Kč / ks]	Cena [€ / ks]	D [mm]	b (mm)	h (mm)	H (mm)	Hmotnost: [kg / ks]
	120	IOORR52	550,-	21,57	125	-	-	500	3,10
	130	IOORR53	585,-	22,95	135	-	-	500	3,30
	150	IOORR55	620,-	24,32	155	-	-	500	3,90
	160	IOORR56	650,-	25,50	165	-	-	500	4,10
	180	IOORR58	710,-	27,85	185	-	-	500	4,50
	200	IOORR50	795,-	31,18	205	-	-	500	5,10
	-	-	-	-	-	-	-	-	-
	-	-	-	-	-	-	-	-	-
	-	-	-	-	-	-	-	-	-
	-	-	-	-	-	-	-	-	-

Trubka s klapkou	Ød	Kód	Cena [Kč / ks]	Cena [€ / ks]	D [mm]	b (mm)	h (mm)	H (mm)	Hmotnost: [kg / ks]
	120	IOORR02	520,-	20,40	125	-	-	250	1,80
	130	IOORR03	530,-	20,79	135	-	-	250	1,90
	150	IOORR05	550,-	21,57	155	-	-	250	2,20
	160	IOORR06	565,-	22,16	165	-	-	250	2,40
	180	IOORR08	605,-	23,73	185	-	-	250	3,00
	200	IOORR00	640,-	25,10	205	-	-	250	3,20
	-	-	-	-	-	-	-	-	-

Koleno 45°	Ød	Kód	Cena [Kč / ks]	Cena [€ / ks]	D (mm)	b (mm)	h (mm)	W (mm)	Hmotnost: [kg / ks]
	120	IOORSB42	380,-	14,91	125	-	207	172	1,20
	130	IOORSB43	400,-	15,69	135	-	215	182	1,40
	150	IOORSB45	415,-	16,28	155	-	230	204	1,80
	160	IOORSB46	425,-	16,67	165	-	235	212	2,20
	180	IOORSB48	445,-	17,46	185	-	246	231	2,40
	200	IOORSB40	495,-	19,42	205	-	262	252	2,60
	-	-	-	-	-	-	-	-	-

Koleno 90°	Ød	Kód	Cena [Kč / ks]	Cena [€ / ks]	D (mm)	b (mm)	h (mm)	W (mm)	Hmotnost: [kg / ks]
	120	IOORSB92	565,-	22,16	125	-	226	226	1,70
	130	IOORSB93	580,-	22,75	135	-	240	240	2,10
	150	IOORSB95	605,-	23,73	155	-	260	260	2,50
	160	IOORSB96	610,-	23,93	165	-	267	267	2,70
	180	IOORSB98	640,-	25,10	185	-	288	288	3,20
	200	IOORSB90	675,-	26,48	205	-	307	307	3,70
	-	-	-	-	-	-	-	-	-

**Pozn.:** Zvýrazněné položky v tabulkách jsou skladem. Ostatní s dodací lhůtou do 10 pracovních dnů.

Koleno 45° s čistícím otvorem	Ød	Kód	Cena [Kč / ks]	Cena [€ / ks]	D (mm)	b (mm)	h (mm)	W (mm)	Hmotnost: [kg / ks]
	120	IORRB42	450,-	17,65	125	-	307	172	1,90
	130	IORRB43	470,-	18,44	135	-	310	182	2,30
	150	IORRB45	500,-	19,61	155	-	328	204	2,70
	160	IORRB46	540,-	21,18	165	-	336	212	2,90
	180	IORRB48	590,-	23,14	185	-	348	231	3,40
	200	IORRB40	635,-	24,91	205	-	363	252	3,90
	-	-	-	-	-	-	-	-	-
	-	-	-	-	-	-	-	-	-

Koleno 90° s čistícím otvorem	Ød	Kód	Cena [Kč / ks]	Cena [€ / ks]	D (mm)	b (mm)	h (mm)	W (mm)	Hmotnost: [kg / ks]
	120	IORRB92	595,-	23,34	125	-	226	226	1,90
	130	IORRB93	610,-	23,93	135	-	240	240	2,30
	150	IORRB95	640,-	25,10	155	-	260	260	2,70
	160	IORRB96	650,-	25,50	165	-	267	267	2,90
	180	IORRB98	675,-	26,48	185	-	288	288	3,40
	200	IORRB90	705,-	27,65	205	-	307	307	3,90
	-	-	-	-	-	-	-	-	-
	-	-	-	-	-	-	-	-	-

Koleno 0-45° nastavitelné	Ød	Kód	Cena [Kč / ks]	Cena [€ / ks]	D (mm)	b (mm)	h (mm)	W (mm)	Hmotnost: [kg / ks]
	120	IORN42	475,-	18,63	125	-	255	-	1,20
	130	IORN43	485,-	19,02	135	-	260	-	1,40
	150	IORN45	495,-	19,42	155	-	265	-	1,80
	160	IORN46	505,-	19,81	165	-	285	-	2,20
	180	IORN48	515,-	20,20	185	-	295	-	2,40
	200	IORN40	530,-	20,79	205	-	285	-	2,60
	-	-	-	-	-	-	-	-	-
	-	-	-	-	-	-	-	-	-

Koleno 0-90° nastavitelné s čistícím otvorem	Ød	Kód	Cena [Kč / ks]	Cena [€ / ks]	D (mm)	b (mm)	h (mm)	W (mm)	Hmotnost: [kg / ks]
	120	IORNBR2	700,-	27,46	125	-	265	-	2,60
	130	IORNBR3	710,-	27,85	135	-	280	-	3,00
	150	IORNBR5	720,-	28,24	155	-	300	-	3,40
	160	IORNBR6	730,-	28,63	165	-	305	-	3,60
	180	IORNBR8	740,-	29,02	185	-	310	-	4,00
	200	IORNBR0	780,-	30,59	205	-	320	-	4,40
	-	-	-	-	-	-	-	-	-
	-	-	-	-	-	-	-	-	-

Koleno UNI nastavitelné s 2 čistícími otvory	Ød	Kód	Cena [Kč / ks]	Cena [€ / ks]	D (mm)	b (mm)	h (mm)	W (mm)	Hmotnost: [kg / ks]
	120	IORNBU2	900,-	35,30	125	-	420	-	3,60
	130	IORNBU3	930,-	36,48	135	-	430	-	4,00
	150	IORNBU5	960,-	37,65	155	-	440	-	4,60
	160	IORNBU6	990,-	38,83	165	-	450	-	5,00
	180	IORNBU8	1 020,-	40,00	185	-	450	-	5,40
	200	IORNBU0	1 090,-	42,75	205	-	450	-	6,00
	-	-	-	-	-	-	-	-	-
	-	-	-	-	-	-	-	-	-

**Pozn.:**

Zvýrazněné položky v tabulkách jsou skladem. Ostatní s dodací lhůtou do 10 pracovních dnů.

# JEDNOVRSTVÝ OCELOVÝ SYSTÉM

## DN 120 – 200 mm

# ORM

Ocel - černá

Kolenový set s čistícím otvorem a klapkou	Ød	Kód	Cena [Kč / ks]	Cena [€ / ks]	D (mm)	b (mm)	h (mm)	W (mm)	Hmotnost: [kg / ks]
	120	IORSRB2	1 995,-	78,24	125	-	600	450	6,80
	130	IORSRB3	2 095,-	82,16	135	-	600	450	8,00
	150	IORSRB5	2 185,-	85,69	155	-	600	450	10,00
	-	-	-	-	-	-	-	-	-
	-	-	-	-	-	-	-	-	-
	-	-	-	-	-	-	-	-	-
	-	-	-	-	-	-	-	-	-
	-	-	-	-	-	-	-	-	-
	-	-	-	-	-	-	-	-	-
	-	-	-	-	-	-	-	-	-

Kolenový set s klapkou	Ød	Kód	Cena [Kč / ks]	Cena [€ / ks]	D (mm)	b (mm)	h (mm)	W (mm)	Hmotnost: [kg / ks]
	-	-	-	-	-	-	-	-	-
	-	-	-	-	-	-	-	-	-
	150	IORSKB5	3 045,-	119,42	155	-	600	450	10,00
	-	-	-	-	-	-	-	-	-
	-	-	-	-	-	-	-	-	-
	-	-	-	-	-	-	-	-	-
	-	-	-	-	-	-	-	-	-
	-	-	-	-	-	-	-	-	-
	-	-	-	-	-	-	-	-	-
	-	-	-	-	-	-	-	-	-

Zděř jednoduchá	Ød	Kód	Cena [Kč / ks]	Cena [€ / ks]	D (mm)	b (mm)	h (mm)	H (mm)	Hmotnost: [kg / ks]
	120	IORZD02	145,-	5,69	140	-	68	127	0,30
	130	IORZD03	155,-	6,08	150	-	68	127	0,40
	150	IORZD05	180,-	7,06	170	-	68	127	0,40
	160	IORZD06	190,-	7,46	180	-	68	127	0,40
	180	IORZD08	210,-	8,24	200	-	68	127	0,50
	200	IORZD00	225,-	8,83	220	-	68	127	0,50

Růžice	Ød	Kód	Cena [Kč / ks]	Cena [€ / ks]	D (mm)	b (mm)	h (mm)	H (mm)	Hmotnost: [kg / ks]
	120	IORRU02	95,-	3,73	225	-	-	-	0,12
	130	IORRU03	105,-	4,12	235	-	-	-	0,14
	150	IORRU05	110,-	4,32	255	-	-	-	0,16
	160	IORRU06	120,-	4,71	265	-	-	-	0,17
	180	IORRU08	130,-	5,10	285	-	-	-	0,19
	200	IORRU00	135,-	5,30	305	-	-	-	0,20

Růžice široká	Ød	Kód	Cena [Kč / ks]	Cena [€ / ks]	D (mm)	b (mm)	h (mm)	H (mm)	Hmotnost: [kg / ks]
	120	IORRUW2	135,-	5,30	305	-	-	-	0,29
	150	IORRUW5	150,-	5,89	335	-	-	-	0,32
	-	-	-	-	-	-	-	-	-
	-	-	-	-	-	-	-	-	-
	-	-	-	-	-	-	-	-	-

Těsnění pro čistící otvor	Ød	Kód	Cena [Kč / ks]	Cena [€ / ks]	D (mm)	b (mm)	h (mm)	H (mm)	Hmotnost: [kg / ks]
	120	IORDRU0	60,-	2,36	-	-	-	-	0,05
	-	-	-	-	-	-	-	-	-
	-	-	-	-	-	-	-	-	-
	-	-	-	-	-	-	-	-	-
	-	-	-	-	-	-	-	-	-

**Pozn.:** Zvýrazněné položky v tabulkách jsou skladem. Ostatní s dodací lhůtou do 10 pracovních dnů.

Žebrovaná trubka	Ød	Kód	Cena [Kč / ks]	Cena [€ / ks]	D (mm)	b (mm)	h (mm)	H (mm)	Hmotnost: [kg / ks]
	120	IORKR52	910,-	35,69	125	-	-	500	5,00
	130	IORKR53	935,-	36,67	135	-	-	500	5,40
	150	IORKR55	960,-	37,65	155	-	-	500	6,40
	160	IORKR56	985,-	38,63	165	-	-	500	6,60
	180	IORKR58	1 035,-	40,59	185	-	-	500	7,40
	200	IORKR50	1 085,-	42,55	205	-	-	500	6,40
	-	-	-	-	-	-	-	-	-
	-	-	-	-	-	-	-	-	-

Příruba proti kondenzátu	Ød	Kód	Cena [Kč / ks]	Cena [€ / ks]	D (mm)	b (mm)	h (mm)	H (mm)	Hmotnost: [kg / ks]
	120	-	-	-	-	-	-	-	-
	130	-	-	-	-	-	-	-	-
	150	-	-	-	-	-	-	-	-
	160	-	-	-	-	-	-	-	-
	180	IORAKF8	705,-	27,65	185	-	-	250	2,40
	200	IORAKF0	735,-	28,83	205	-	-	250	2,80
	-	-	-	-	-	-	-	-	-
	-	-	-	-	-	-	-	-	-

Přechodový díl pro keramické komíny	Ød	Kód	Cena [Kč / ks]	Cena [€ / ks]	D (mm)	b (mm)	h (mm)	H (mm)	Hmotnost: [kg / ks]
	120/160	IORKC120160	690,-	27,06	125	-	-	-	1,00
	130/160	IORKC130160	690,-	27,06	135	-	-	-	1,20
	150/160	IORKC150160	690,-	27,06	155	-	-	-	1,40
	160/160	IORKC160160	690,-	27,06	165	-	-	-	1,50
	120/180	IORKC120180	735,-	28,83	125	-	-	-	1,40
	130/180	IORKC130180	735,-	28,83	135	-	-	-	1,20
	150/180	IORKC150180	735,-	28,83	155	-	-	-	1,40
	160/180	IORKC160180	735,-	28,83	165	-	-	-	1,60
	180/180	IORKC180180	735,-	28,83	185	-	-	-	1,60
	120/200	IORKC120200	795,-	31,18	125	-	-	-	1,60
	130/200	IORKC130200	795,-	31,18	135	-	-	-	1,40
	150/200	IORKC150200	795,-	31,18	155	-	-	-	1,60
	160/200	IORKC160200	795,-	31,18	165	-	-	-	1,60
	180/200	IORKC180200	795,-	31,18	185	-	-	-	1,80
	200/200	IORKC200200	795,-	31,18	205	-	-	-	1,80

Opravný sprej	ml	Kód	Cena [Kč / ks]	Cena [€ / ks]	D (mm)	b (mm)	h (mm)	H (mm)	Hmotnost: [kg / ks]
	150	IORFS15	430,-	16,87	-	-	-	-	0,20
	400	IORFS40	605,-	23,73	-	-	-	-	0,42
	-	-	-	-	-	-	-	-	-
	-	-	-	-	-	-	-	-	-
	-	-	-	-	-	-	-	-	-
	-	-	-	-	-	-	-	-	-

Centrická redukce	Ød	Kód	Cena [Kč / ks]	Cena [€ / ks]	D (mm)	b (mm)	h (mm)	H (mm)	Hmotnost: [kg / ks]
	120	IORKAxxxxxx	455,-	17,85	-	-	-	-	-
	130				-	-	-	-	-
	150				-	-	-	-	-
	160				-	-	-	-	-
	180				-	-	-	-	-
	200				-	-	-	-	-

**Pozn.:**

Zvýrazněné položky v tabulkách jsou skladem. Ostatní s dodací lhůtou do 10 pracovních dnů.

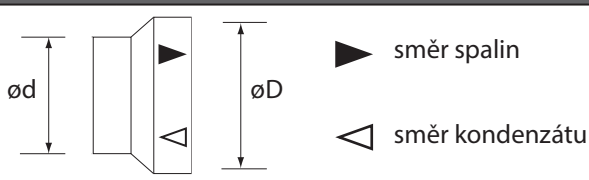

Objednávání redukci:		Příklad objednávání redukci:
 <p>                 ▲ směr spalin                  ▼ směr kondenzátu             </p> <p>                 ød                  øD             </p> <p>                 Cenu redukce určuje to DN, které je na redukci větší.                  Rozměr ød je vždy vnější, rozměr øD je vždy vnitřní.                  Do objednáčímho znaku redukce zadejte zleva do prava:                  ød a øD v milimetrech.             </p> <p> <b>ød = signa, hrdlo spotřebiče (kotel)</b>  <b>øD = hrdlo, komínový systém</b> </p>		<p>Potřebujete v systému <b>ORM</b> udělat redukci pro dopojení kouřovodu ke spotřebiči paliv. Dimenze se bude měnit z DN 120 mm na DN 150mm.</p> <p><b>Řešení:</b>                  Zvolím „<b>Redukci v systému ORM centrickou</b>“                  S objednáčím znakem: <b>IORKA120150</b>                  Cena redukce bude stanovena podle DN 150 mm.</p>
<b>Typ redukce</b>	<b>IORKAxxxxxx</b>	
ød ( mm )		
øD ( mm )		

**Pozn.:**  
 Zvýrazněné položky v tabulkách jsou skladem. Ostatní s dodací lhůtou do 10 pracovních dnů.

**PL**

Jednovrstvý ocelový systém **s tloušťkou stěny 1,2 mm** pro dopojení spotřebičů na pelety. Barva - černá.

**Vlastnosti systému:**

- pro pevná paliva
- pro kouřovody
- pro přetlakový provoz
- odolný proti vlhkosti
- spojování hrdlem s těsněním
- rychlá a jednoduchá montáž

Ocelový pevný spalinový systém **ALMEVA Easy PL** je vhodný pro odvod spalin od spotřebičů na pelety, pracující v přetlakovém režimu. Je vyroben z oceli třídy EN 10025-5/S 235 JRG 2.

**Pozn.:**

Zvýrazněné položky v tabulkách jsou skladem.

Technická data pro **ALMEVA Easy PL:**

**Třída oceli: EN 10025-5/S 235 JRG 2**

**Zatřídění dle EN 1856 - 2:**

PL	EN 1856-2 T200 P1 W Vm L01120 O50
----	-----------------------------------

# JEDNOVRSTVÝ OCELOVÝ SYSTÉM

## DN 80 a 100 mm

**PL**  
Ocel – černý lak

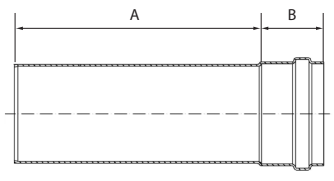
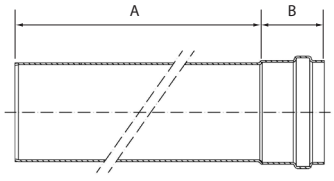
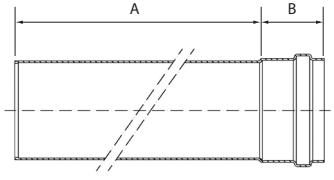
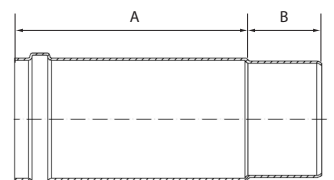
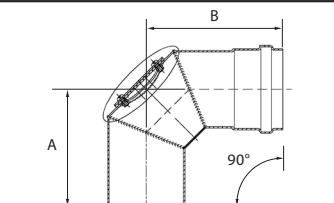
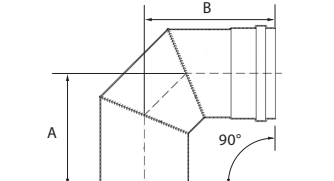
Rovný díl 200mm	Ød	Kód	Cena [Kč / ks]	Cena [€ / ks]	A (mm)	B (mm)	C (mm)	D (mm)	Hmotnost: [kg / ks]
	80	IPLRM08	500,-	19,61	200	50	-	-	0,60
	100	IPLRM01	565,-	22,16	200	50	-	-	0,75
Rovný díl 450mm	Ød	Kód	Cena [Kč / ks]	Cena [€ / ks]	A (mm)	B (mm)	C (mm)	D (mm)	Hmotnost: [kg / ks]
	80	IPLRM58	585,-	22,94	450	50	-	-	1,20
	100	IPLRM51	660,-	25,88	450	50	-	-	1,50
Rovný díl 950mm	Ød	Kód	Cena [Kč / ks]	Cena [€ / ks]	A (mm)	B (mm)	C (mm)	D (mm)	Hmotnost: [kg / ks]
	80	IPLRM18	890,-	34,90	950	50	-	-	2,37
	100	IPLRM11	1 005,-	39,41	950	50	-	-	3,01
Nastavitelný díl 210mm	Ød	Kód	Cena [Kč / ks]	Cena [€ / ks]	A (mm)	B (mm)	C (mm)	D (mm)	Hmotnost: [kg / ks]
	80	IPLSR08	715,-	28,04	150	50	-	-	0,53
	-	-	-	-	-	-	-	-	-
Revizní koleno 90°	Ød	Kód	Cena [Kč / ks]	Cena [€ / ks]	A (mm)	B (mm)	C (mm)	D (mm)	Hmotnost: [kg / ks]
	80	IPLRB98	1 220,-	47,84	-	142	-	-	0,61
	100	IPLRB91	1 495,-	58,63	-	148	-	-	0,80
Koleno 90°	Ød	Kód	Cena [Kč / ks]	Cena [€ / ks]	A (mm)	B (mm)	C (mm)	D (mm)	Hmotnost: [kg / ks]
	80	IPLSB98	900,-	35,29	-	141	-	-	0,58
	100	IPLSB91	1 240,-	48,63	-	-	-	-	0,76

**Pozn.:**

Zvýrazněné položky v tabulkách jsou skladem. Ostatní s dodací lhůtou do 10 pracovních dnů.

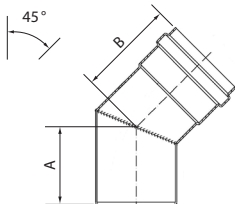
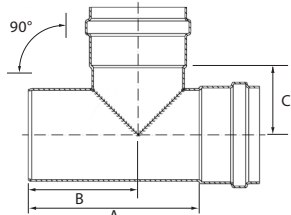
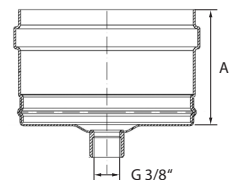
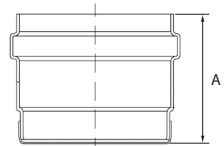
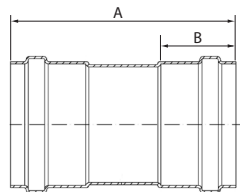
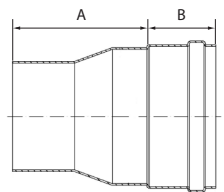
Koleno 45°	Ød	Kód	Cena [Kč / ks]	Cena [€ / ks]	A (mm)	B (mm)	C (mm)	D (mm)	Hmotnost: [kg / ks]
	80	IPLSB48	845,-	33,14	-	-	-	-	0,43
	100	IPLSB41	1 105,-	43,33	-	-	-	-	0,55
Sopouch 90°	Ød	Kód	Cena [Kč / ks]	Cena [€ / ks]	A (mm)	B (mm)	C (mm)	D (mm)	Hmotnost: [kg / ks]
	80	IPLTE98	910,-	35,69	150	-	60	-	0,66
	100	IPLTE91	995,-	39,02	185	115	75	-	0,92
Kondenzát. jímka s odtok. dolů	Ød	Kód	Cena [Kč / ks]	Cena [€ / ks]	A (mm)	B (mm)	C (mm)	D (mm)	Hmotnost: [kg / ks]
	80	IPLMA08	440,-	17,25	50	-	-	-	0,23
	100	IPLMA01	480,-	18,82	68	-	-	-	0,29
Záslepka sopouchu	Ød	Kód	Cena [Kč / ks]	Cena [€ / ks]	A (mm)	B (mm)	C (mm)	D (mm)	Hmotnost: [kg / ks]
	80	IPLEN08	430,-	16,86	70	-	-	-	0,22
	100	IPLEN01	480,-	18,82	68	-	-	-	0,29
Spojka s dvojitým hrdlem	Ød	Kód	Cena [Kč / ks]	Cena [€ / ks]	A (mm)	B (mm)	C (mm)	D (mm)	Hmotnost: [kg / ks]
	80	IPLDM08	560,-	21,96	150	50	-	-	0,37
	100	IPLDM01	630,-	24,71	150	50	-	-	0,46
Centrická redukce	Ød	Kód	Cena [Kč / ks]	Cena [€ / ks]	A (mm)	B (mm)	C (mm)	D (mm)	Hmotnost: [kg / ks]
	80/100	IPLKA01	405,-	15,88	98	50	-	-	0,17

**Pozn.:**

Zvýrazněné položky v tabulkách jsou skladem. Ostatní s dodací lhůtou do 10 pracovních dnů.

# JEDNOVRSTVÝ OCELOVÝ SYSTÉM

## DN 80 a 100 mm

**PL**  
Ocel – černý lak

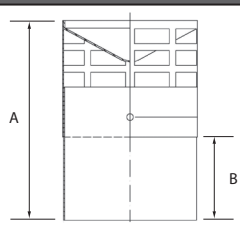
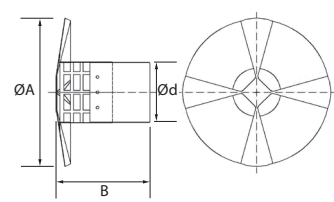
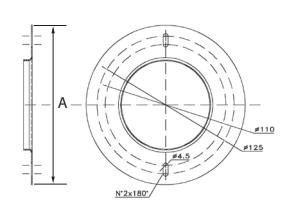
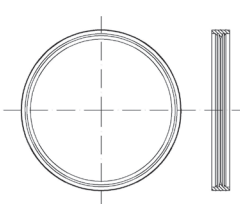
Ochranný košík	Ød	Kód	Cena [Kč / ks]	Cena [€ / ks]	A (mm)	B (mm)	C (mm)	D (mm)	Hmotnost: [kg / ks]
	80	IPLIN08	780,-	30,59	-	-	-	-	0,16
	100	IPLIN01	870,-	34,12	120	50	-	-	0,21
Protidešťová hlavice	Ød	Kód	Cena [Kč / ks]	Cena [€ / ks]	A (mm)	B (mm)	C (mm)	D (mm)	Hmotnost: [kg / ks]
	80	IPLRS58	1 080,-	42,35	195	125,5	-	-	0,27
	100	IPLRS51	1 210,-	47,45	210	134	-	-	0,31
Růžice	Ød	Kód	Cena [Kč / ks]	Cena [€ / ks]	A (mm)	B (mm)	C (mm)	D (mm)	Hmotnost: [kg / ks]
	80	IPLRU08	300,-	11,76	145	-	-	-	0,08
	100	IPLRU01	335,-	13,14	180	-	-	-	0,07
Těsnění (silikonové)	Ød	Kód	Cena [Kč / ks]	Cena [€ / ks]	A (mm)	B (mm)	C (mm)	D (mm)	Hmotnost: [kg / ks]
	80	IPLMDE8	85,-	3,33	-	-	-	-	0,01
	100	IPLMDE1	95,-	3,73	-	-	-	-	0,01

**Pozn.:**

Zvýrazněné položky v tabulkách jsou skladem. Ostatní s dodací lhůtou do 10 pracovních dnů.



## Tlumiče hluku

Absorpční tlumiče hluku **ALMEVA ASD** slouží k efektivnímu snížení emisí hluku ze spotřebičů. Tyto tlumiče jsou kompatibilní s nerezovým systémem odvodu spalin **ALMEVA EW** v dimenzích od 80 do 500 mm.

K dispozici jsou absorpční tlumiče hluku **ALMEVA ASD** v celkových délkách od 700 do 2200 mm.

Průměr vlastního tlumiče:
280 mm pro DN 80
300 mm pro DN 100 a 110
355 mm pro DN 120, 130 a 150
400 mm pro DN 180 a 200
450 mm pro DN 230 a 250
500 mm pro DN 300
560 mm pro DN 350
600 mm pro DN 400
630 mm pro DN 450
710 mm pro DN 500

Absorpční tlumiče hluku **ALMEVA ASD** jsou vhodné pro snížení hladiny hluku pro plynové a olejové spotřebiče. Tlumiče je možné použít v podtlakovém provozu (s přirozeným tahem), při použití těsnění také v přetlakovém provozu. Kvalitní nerezová ocel třídy 1.4404 a kvalitní technické řešení umožňuje jak suchý tak mokrý provoz.

Na přání může být tlumič doplněn odvodem kondenzátu ve vnějším plášti (v závislosti na instalaci).

### Pozn.:

Dodací lhůta do 15 pracovních dnů.

# ABSORPČNÍ TLUMIČE HLUKU DN 80 – 500 mm

Absorpční tlumič hluku spalin 0,75 m	Ød	Kód	Cena [Kč / ks]	Cena [€ / ks]	ØD	Ln (mm)	Hmotnost [kg / ks]	
	80	IISD0508	14 442,-	566,34	280	500	5,25	
	100	IISD0510	15 680,-	614,88	300	500	6,20	
	110	IISD0511	16 015,-	628,02	300	500	6,25	
	120	IISD0512	16 217,-	635,96	355	500	6,30	
	130	IISD0513	18 158,-	712,04	355	500	6,40	
	150	IISD0515	18 719,-	734,07	355	500	6,50	
	180	IISD0518	21 076,-	826,49	400	500	7,20	
	200	IISD0520	21 639,-	848,56	400	500	7,35	
	-	-	-	-	-	-	-	-
	-	-	-	-	-	-	-	-
Absorpční tlumič hluku spalin 1,25 m	Ød	Kód	Cena [Kč / ks]	Cena [€ / ks]	ØD	Ln (mm)	Hmotnost [kg / ks]	
	80	IISD1008	22 691,-	889,83	280	1000	10,45	
	100	IISD1010	23 185,-	909,18	300	1000	12,40	
	110	IISD1011	23 674,-	928,38	300	1000	12,50	
	120	IISD1012	23 985,-	940,55	355	1000	12,60	
	130	IISD1013	25 170,-	987,02	355	1000	12,63	
	150	IISD1015	27 816,-	1 090,81	355	1000	12,65	
	180	IISD1018	32 491,-	1 274,13	400	1000	14,35	
	200	IISD1020	33 786,-	1 324,94	400	1000	14,50	
	230	IISD1023	37 524,-	1 471,51	450	1000	24,40	
	250	IISD1025	38 894,-	1 525,22	450	1000	24,75	
	300	IISD1030	56 281,-	2 207,07	500	1000	27,00	
	350	IISD1035	68 696,-	2 693,94	560	1000	30,50	
	400	IISD1040	75 847,-	2 974,37	600	1000	38,80	
	450	IISD1045	83 231,-	3 263,94	630	1000	42,75	
	500	IISD1050	106 859,-	4 190,52	710	1000	46,20	
	Absorpční tlumič hluku spalin 1,75 m	Ød	Kód	Cena [Kč / ks]	Cena [€ / ks]	ØD	Ln (mm)	Hmotnost [kg / ks]
	230	IISD1523	56 396,-	2 211,59	450	1500	36,60	
	250	IISD1525	58 486,-	2 293,54	450	1500	37,13	
	300	IISD1530	68 672,-	2 693,01	500	1500	40,50	
	350	IISD1535	85 295,-	3 344,88	560	1500	45,75	
	400	IISD1540	106 083,-	4 160,08	600	1500	58,20	
	450	IISD1545	131 911,-	5 172,98	630	1500	64,13	
	500	IISD1550	164 117,-	6 435,96	710	1500	92,40	
	-	-	-	-	-	-	-	
	-	-	-	-	-	-	-	
	-	-	-	-	-	-	-	
Absorpční tlumič hluku spalin 2,25 m	Ød	Kód	Cena [Kč / ks]	Cena [€ / ks]	ØD	Ln (mm)	Hmotnost [kg / ks]	
	80	IISD2008	45 362,-	1 778,90	280	2000	20,90	
	100	IISD2010	49 490,-	1 940,75	300	2000	24,80	
	110	IISD2011	50 643,-	1 986,00	300	2000	25,00	
	120	IISD2012	51 324,-	2 012,69	355	2000	25,10	
	130	IISD2013	57 993,-	2 274,22	355	2000	25,20	
	150	IISD2015	59 766,-	2 343,76	355	2000	25,30	
	180	IISD2018	67 704,-	2 655,05	400	2000	28,70	
	200	IISD2020	69 472,-	2 724,37	400	2000	29,10	
	230	IISD2023	77 331,-	3 032,58	450	2000	48,80	
	250	IISD2025	80 204,-	3 145,24	450	2000	49,50	
	300	IISD2030	94 270,-	3 696,84	500	2000	54,00	
	350	IISD2035	117 256,-	4 598,24	560	2000	61,00	
	400	IISD2040	146 040,-	5 727,04	600	2000	77,60	
	450	IISD2045	181 861,-	7 131,78	630	2000	85,50	
	500	IISD2050	226 557,-	8 884,55	710	2000	92,40	

**Pozn.:**  
Dodací lhůta do 15 pracovních dnů.

## Míra tlumení

Tlumič je vyplněn minerální izolací a díky tomu je míra tlumení pro různé frekvence odlišná v závislosti na použitém typu (délce) tlumiče. V tabulkách je uvedeno odpovídající tlumení v závislosti na frekvenci pro danou dimenzi, vždy pro konkrétní délku těla tlumiče od 0,5 do 2 m.

Ød [mm]	ØD [mm]	Prvek [kód]	Ln [mm]	Vložené tlumení $D_e$ v dB při frekvenci								Povrch [m <sup>2</sup> ]
				63 Hz	125 Hz	250 Hz	500 Hz	1 kHz	2 kHz	4 kHz	8 kHz	
80	280	IISD0508	500	3	9	14	23	25	19	15	11	0,505
		IISD1008	1000	5	17	28	47	52	38	31	23	1,011
		IISD2008	2000	9	31	52	87	96	70	57	43	2,022
100	300	IISD0510	500	2	8	13	22	21	13	8	5	0,542
		IISD1010	1000	5	16	26	45	43	26	15	11	1,083
		IISD2010	2000	8	30	49	82	79	47	28	19	2,167
110	300	IISD0511	500	2	8	13	22	21	13	8	5	0,542
		IISD1011	1000	5	16	26	45	43	26	15	11	1,083
		IISD2011	2000	8	30	49	82	79	47	28	19	2,167
120	355	IISD0512	500	2	7	13	22	21	13	8	5	0,709
		IISD1012	1000	4	15	26	45	43	26	15	11	1,289
		IISD2012	2000	7	29	49	82	79	47	28	19	2,565
130	355	IISD0513	500	2	7	13	22	21	13	8	5	0,709
		IISD1013	1000	4	15	26	45	43	26	15	11	1,289
		IISD2013	2000	7	29	49	82	79	47	28	19	2,565
150	355	IISD0515	500	2	8	14	23	22	12	7	5	0,709
		IISD1015	1000	4	15	25	42	41	23	13	9	1,289
		IISD2015	2000	10	21	41	69	65	42	26	16	2,565
180	400	IISD0518	500	2	7	12	19	20	11	5	3	0,795
		IISD1018	1000	3	14	24	38	39	21	10	7	1,445
		IISD2018	2000	8	19	45	72	69	55	28	14	2,167
200	400	IISD0520	500	2	5	10	16	15	7	3	3	0,801
		IISD1020	1000	2	8	17	27	25	12	5	3	1,457
		IISD2020	2000	7	19	38	61	59	49	25	12	2,172
230	450	IISD1023	1000	3	11	22	34	32	16	8	6	1,635
		IISD1523	1500	5	17	32	50	48	23	11	9	2,437
		IISD2023	2000	7	18	38	61	59	49	25	12	3,25
250	450	IISD1025	1000	3	11	20	31	29	13	7	5	1,654
		IISD1525	1500	4	16	30	46	44	20	10	7	2,445
		IISD2025	2000	5	17	37	56	54	24	13	8	3,272
300	500	IISD1030	1000	3	9	18	29	27	12	7	5	1,84
		IISD1530	1500	5	14	27	44	41	18	11	8	2,716
		IISD2030	2000	6	17	33	54	50	22	13	9	3,624
350	560	IISD1035	1000	3	7	15	25	26	12	9	7	2,096
		IISD1535	1500	5	11	23	38	39	18	14	11	2,785
		IISD2035	2000	6	10	25	38	43	22	16	13	5,833
400	600	IISD1040	1000	3	5	14	20	25	12	9	7	2,21
		IISD1540	1500	5	8	21	31	38	18	14	11	2,967
		IISD2040	2000	6	10	25	38	42	22	16	13	6,231
450	630	IISD1045	1000	3	5	13	19	24	11	8	6	2,285
		IISD1545	1500	5	8	20	29	36	17	12	9	3,428
		IISD2045	2000	6	10	24	38	41	20	15	11	6,855
500	710	IISD1050	1000	3	5	13	19	23	11	8	6	2,63
		IISD1550	1500	5	8	19	28	35	17	12	9	3,945
		IISD2050	2000	6	9	24	35	40	20	15	11	7,89

Hodnoty jsou zjištěné v oktávové střední frekvenci podle ČSN/STN EN ISO 7235:2009.



## PoV, Komínové štítky

Prohlášení o vlastnostech



Komínové štítky







# OSTATNÍ INFORMACE

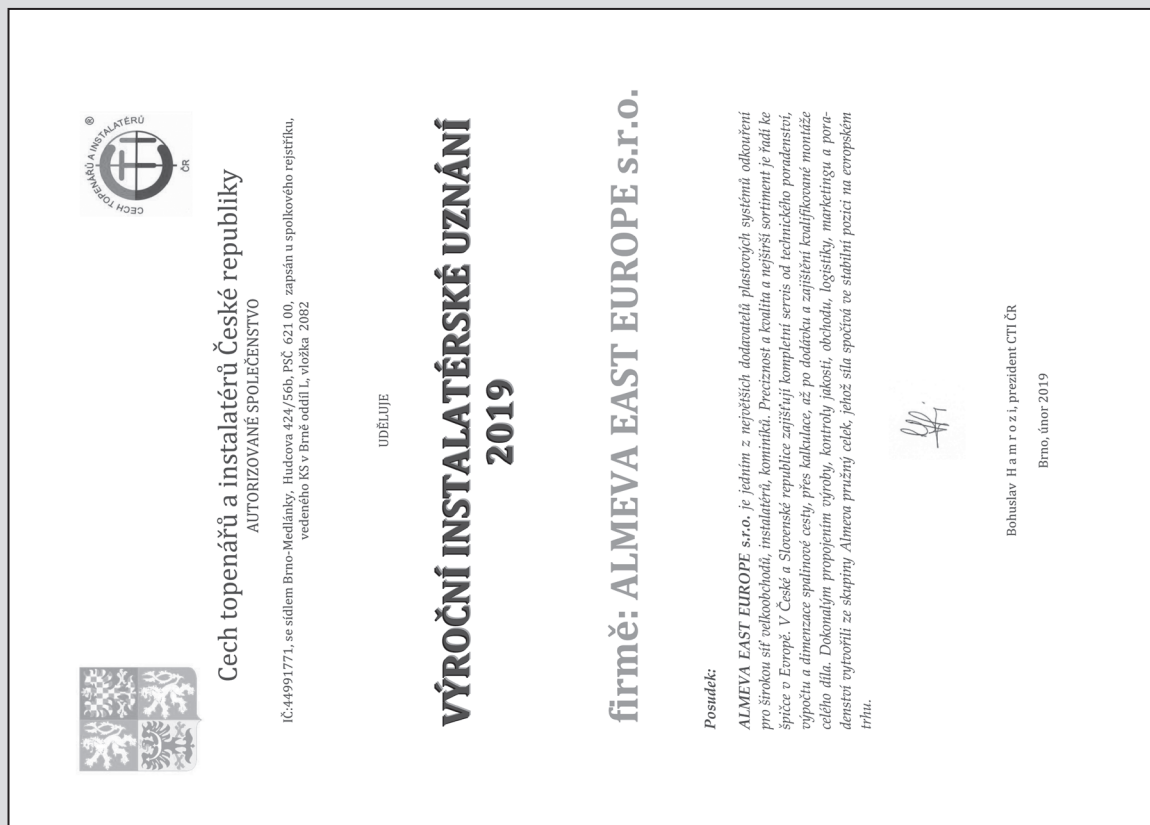

# OSTATNÍ INFORMACE



Navrženo  
ve Švýcarsku



Více než 9 000  
kominových prvků



3 000 položek  
skladem



Profesionální  
technická podpora



Osvědčení o kvalitě  
Hospodářské komory ČR



Najděte svého obchodního zástupce



Nájdite svojho obchodného zástupcu

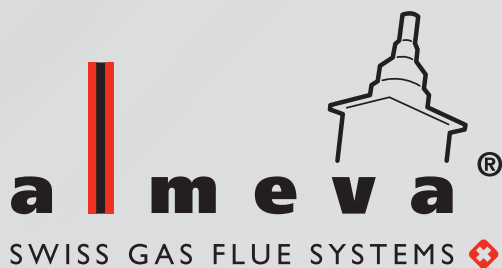
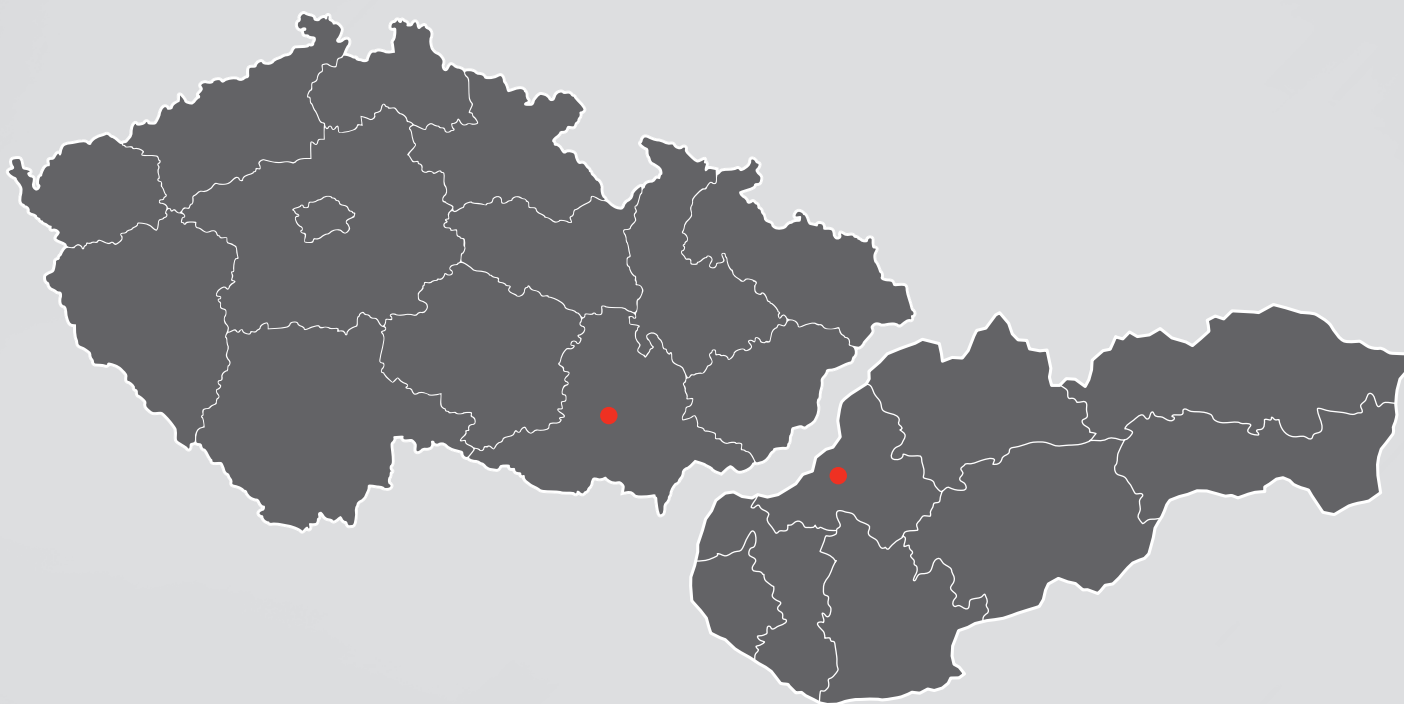

**ALMEVA EAST EUROPE a.s.**

Družstevní 501  
664 43 Želešice  
Česká republika  
Tel.: +420 513 033 101  
E-mail: cz@almeva.eu

**ALMEVA SLOVAKIA s. r. o.**

Bratislavská 119  
911 05 Trenčín  
Slovensko  
Tel.: +421 32 202 8946  
E-mail: sk@almeva.eu