

spájkované tvarovky

informácie o výrobku



viega

obsah

1	Popis skupiny výrobkov	3
2	Certifikáty	4
3	Rozmery Z	6
4	Imprint	46

Popis skupiny výrobkov

Spájkované tvarovky z červeného bronzu a medi pre medené rúry.

Označenie

Výrobca, rozmer rúry, šarža, označenia schválení (DVGW), značka kvality RAL-GZ 641/3 (pre d12–54)



Rozmery

d6–108,0

Upozornenie – normy a schválenia

Spojky z červeného bronzu podľa pracovného listu DVGW GW 6.

Spojky z medi podľa pracovného listu DVGW GW 8 vhodné pre medené rúry podľa pracovného listu DVGW GW 392.

Dohoda o záruke BHKS a ZVSHK pre spojky z medi a červeného bronzu, ako aj stenové priechodky z červeného bronzu.

Schválenie spojok z červeného bronzu podľa pracovného listu DVGW reg. č. DV-7401AO2956.

Schválenie spojok z medi podľa pracovného listu DVGW reg. č. DV-7411AO2955.

Modely kolien 95090 a 95092 nie sú schválené na použitie v inštaláciách plynu a pitnej vody.

Materiály lisovacích spojok

Med: 99,9 % Cu-DHP









Červený bronz: CC499K

Zmeny a chyby sú vyhradené!

Aktuálne rozmery Z a montážne rozmery, ako aj ďalšie technické informácie nájdete na internetovej stránke Viega a pred nákupom, počas plánovania, výstavby a používania je nutné ich skontrolovať. Naše výrobky sú kontinuálne optimalizované.

Tento popis produktu obsahuje dôležité informácie o výbere produktu resp. systému, inštalácii a uvedení do prevádzky, ako aj o použití v súlade so stanoveným účelom a v prípade potreby o údržbových opatreniach. Tieto informácie o produktoch, ich vlastnostiach a aplikačných technikách vychádzajú z aktuálne platných noriem v Európe (napr. EN) a/alebo v Nemecku (napr. DIN/DVGW). Niektoré časti textu môžu odkazovať na technické predpisy v Európe/Nemecku. Mali by sa považovať za odporúčania pre ďalšie krajiny, kde neexistujú príslušné národné požiadavky. Príslušné národné zákony, štandardy, nariadenia, normy a ďalšie technické predpisy majú prednosť pred nemeckými/európskymi smernicami tohoto popisu produktu: Tu uvedené informácie nie sú záväzné pre iné krajiny a oblasti a mali by sa chápať ako odporúčanie.

Certifikáty

	<p>ÜA sign Profipress, solder fittings, threaded fittings</p>
	<p>ÜA sign Sanpress, Raxofix, Maxiplex, bronze threaded fittings, solder fittings</p>
	<p>DVGW type examination certificate Soldered fittings (d 12 - 54)</p>
	<p>DVGW type examination certificate Soldered fittings (d 12 - 54)</p>
<p>KIWA</p>	<p>KIWA UK REGULATION 4 Approval Soldered fittings</p>
	<p>WRAS Certificate Soldered fittings</p>
<p>VIK-HR</p>	<p>VIK-HR Inspection Certificate 3.2 Soldered fittings</p>
	<p>ICIM Hygiene certificate Profipress, Profipress XL, Sanpress Inox, Sanpress Inox XL, Sanpress, Sanpress XL, Sanfix Fosta, Raxofix, Smartpress, gunmetal threaded fittings, soldered fittings</p>
	<p>Gastec Certificate Soldered fittings</p>
	<p>Gastec Certificate Soldered fittings (Hydrogen gas)</p>
	<p>KIWA Product certificate Soldered fittings</p>

IZV	IZV Certificate Soldered fittings
-----	---

Rozmery Z

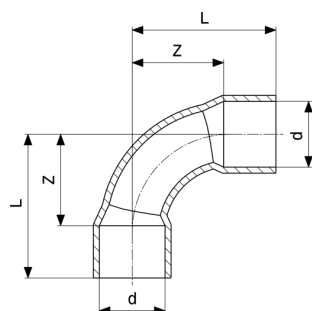

Oblúk 90°
- meď
model 95002A

artikel	Cu	d	Z	L
122 645		6	8	14
109 288		8	10	17
102 494		10	14	22
100 513	✓	12	14	23
467 463	✓	14	17	28
100 018	✓	15	18	29
467 470	✓	16	19	30
100 148	✓	18	21	34
100 063	✓	22	26	42
100 193	✓	28	33	52
101 046	✓	35	42	65
102 777	✓	42	50	77
104 115	✓	54	65	97
119 829		64,0	83	116
125 080		76,1	100	134
127 077		88,9	112	150
138 431		108,0	177	225

Cu = zaistenie kvality pre d12 – 54

Z = rozmer Z

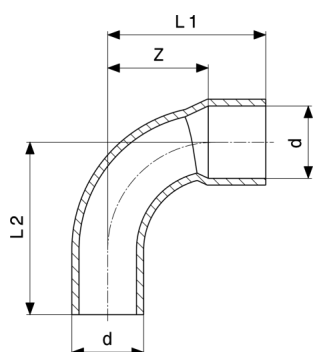

Oblúk 90°
- meď
model 95001A

artikel	Cu	d	Z	L1	L2
117 184		8	10	17	18
105 136		10	14	22	24
101 510	✓	12	14	23	25
465 742	✓	14	17	28	28
100 155	✓	15	18	29	31
467 456	✓	16	19	30	30
100 575	✓	18	22	35	37
100 391	✓	22	26	42	43
100 827	✓	28	34	53	55
103 415	✓	35	42	65	67
108 052	✓	42	50	77	79
112 028	✓	54	65	97	98
594 350		64,0	76	109	111
634 254		76,1	92	125	128
634 261*		88,9	107	145	148

Cu = zaistenie kvality pre d12 – 54

Z = rozmer Z

* = dodávka len do vyčerpania skladových zásob

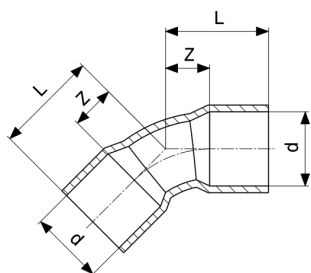

Oblúk 45°
- meď
model 95041

artikel	Cu	d	Z	L
110 420		10	6	14
103 309	✓	12	5	14
467 500	✓	14	6	17
100 483	✓	15	6	17
467 517	✓	16	7	18
101 077	✓	18	8	21
100 704	✓	22	9	25
101 459	✓	28	12	31
104 016	✓	35	15	38
108 823	✓	42	17	44
112 196	✓	54	22	54
138 394		64,0	37	70
144 043		76,1	33	67
144 425		88,9	40	78
158 071		108,0	62	110

Cu = zaistenie kvality pre d12 – 54

Z = rozmer Z

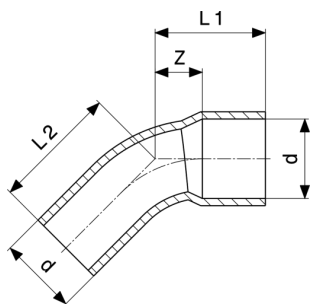

Oblúk 45°
- meď
model 95040

artikel	Cu	d	Z	L1	L2
109 325		10	6	14	16
103 019	✓	12	5	15	16
467 487	✓	14	6	17	17
100 292	✓	15	6	17	19
467 494	✓	16	7	18	18
100 773	✓	18	8	21	22
100 605	✓	22	9	25	27
101 336	✓	28	12	31	33
104 955	✓	35	15	38	40
110 338	✓	42	17	44	46
114 916	✓	54	22	54	56
594 244		64,0	32	64	66
633 837		76,1	38	71	74
633 844*		88,9	44	82	85

Cu = zaistenie kvality pre d12 – 54

Z = rozmer Z

* = dodávka len do vyčerpania skladových zásob

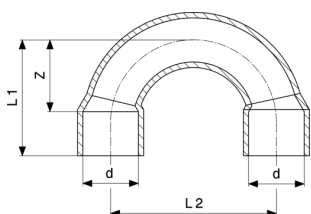

Oblúk 180°
- meď
model 95060

artikel	d	Z	L1	L2
117 542	10	17	25	30
121 785	12	17	26	34
115 951	15	23	34	45
113 445	18	26	39	52

Z = rozmer Z

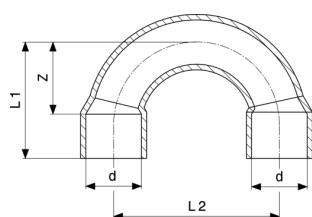

Oblúk 180°
- meď
model 95060

artikel	d	Z	L1	L2
121 518	22	32	48	66
128 029	28	41	60	84

Z = rozmer Z

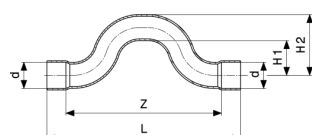

Nadoblúk
- meď
model 95085

artikel	Cu	d	Z	L	v1	v2
102 159	✓	15	90	112	20	35
104 672	✓	18	102	128	20	38
103 798	✓	22	115	147	23	45

Cu = zaistenie kvality pre d12 – 54

Z = rozmer Z

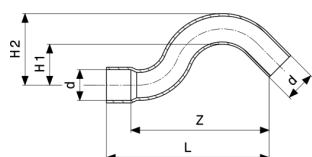

Nadoblúk
- meď
model 95086

artikel	Cu	d	Z	L	v1	v2
107 864*	✓	12	66	76	20	32
102 012	✓	15	68	80	20	35
104 481	✓	18	73	87	20	38
105 396	✓	22	87	104	23	45

Cu = zaistenie kvality pre d12 – 54

Z = rozmer Z

* = dodávka len do vyčerpania skladových zásob

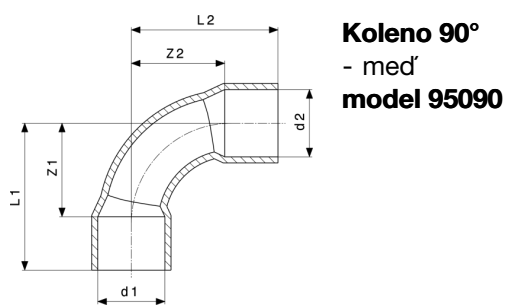

artikel	NF	d1	d2	Z1	Z2	L1	L2
107 901	✓	8	8	7	7	14	14
103 132	✓	10	10	14	14	22	22
100 803	✓	12	12	12	12	21	21
467 524	✓	14	14	14	14	25	25
116 897*		15	12	15	21	26	30
100 094	✓	15	15	10	10	21	21
467 531	✓	16	16	16	16	27	27
100 452	✓	18	18	12	12	25	25
100 278	✓	22	22	15	15	31	31
100 711	✓	28	28	19	19	38	38
103 088	✓	35	35	28	28	51	51
106 416	✓	42	42	34	34	61	61
109 905	✓	54	54	45	45	77	77
594 411		64,0	64,0	76	76	109	109
594 428		76,1	76,1	67	67	100	100
594 435*		88,9	88,9	79	79	116	116
594 442*		108,0	108,0	130	130	178	178

* = dodávka len do vyčerpania skladových zásob

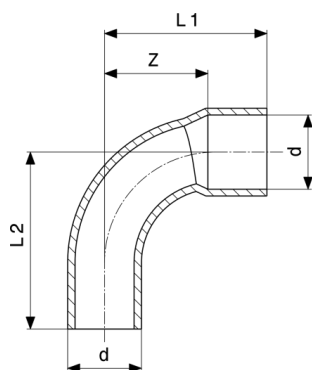

**Koleno 90°
- med' model 95092**

artikel	d	Z	L1	L2
113 773	8	11	18	18
108 700	10	14	22	24
102 920	12	12	21	25
467 548	14	14	25	25
100 414	15	12	23	25
467 555	16	16	27	27
101 169	18	14	27	30
100 933	22	15	31	37
102 067	28	25	44	47
107 079	35	28	51	55
113 995	42	34	61	65
118 891	54	45	77	81

Z = rozmer Z

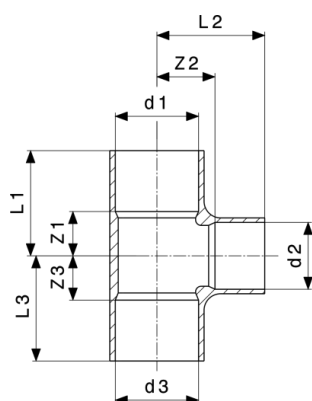

T-kus
- med'
model 95130

artikel	Cu	NF	d1	d2	d3	Z1	Z2	Z3	L1	L2
107 475			6	6	6	5	4	5	11	10
128 968			8	6	8	6	7	6	13	13
105 747		✓	8	8	8	6	5	6	13	12
120 009			10	6	10	4	6	4	13	13
104 092		✓	10	10	10	6	6	6	14	14
136 635		✓	12	8	12	7	9	7	16	16
109 745		✓	12	10	12	7	8	7	16	16
101 435	✓	✓	12	12	12	7	7	7	16	16
584 412*	✓	✓	14	12	12	8	8	14	19	17
467 586	✓	✓	14	12	14	8	8	8	19	17
584 429*	✓	✓	14	14	12	8	8	15	19	19
467 562	✓	✓	14	14	14	8	8	8	19	19
584 436*	✓	✓	14	16	14	9	9	9	20	20
120 245		✓	15	8	15	8	12	8	19	19
106 355		✓	15	10	15	8	11	8	19	19
103 569	✓	✓	15	12	12	8	11	14	19	20
101 848	✓	✓	15	12	15	8	11	8	19	20
104 863	✓	✓	15	15	12	8	9	15	19	20
100 131	✓	✓	15	15	15	8	9	8	19	20
103 200	✓	✓	15	18	15	13	10	13	24	23
105 143	✓	✓	15	22	15	16	13	16	27	29
584 443*	✓	✓	16	12	14	8	9	14	19	18
467 593	✓	✓	16	12	16	8	9	8	19	18
584 962*	✓	✓	16	14	12	8	9	16	19	20
584 955	✓	✓	16	14	14	8	9	13	19	20

Cu = zaistenie kvality pre d12 – 54

* = dodávka len do vyčerpania skladových zásob

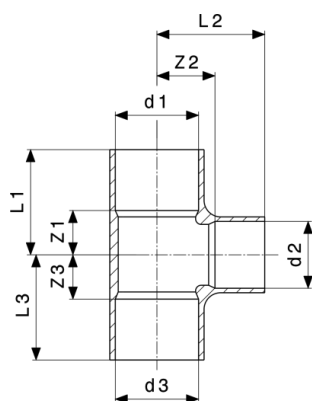

T-kus
- med'
model 95130

artikel	Cu	NF	d1	d2	d3	Z1	Z2	Z3	L1	L2
467 609	✓	✓	16	14	16	8	9	8	19	20
467 579	✓	✓	16	16	16	9	9	9	20	20
584 979	✓	✓	16	18	14	13	11	16	24	24
584 986*	✓	✓	16	18	16	13	11	13	24	24
120 122	✓	✓	18	12	12	8	13	8	21	22
107 413	✓	✓	18	12	15	8	13	14	21	22
103 606	✓	✓	18	12	18	8	13	8	21	22
584 993	✓	✓	18	14	14	8	10	14	21	21
585 006*	✓	✓	18	14	16	8	10	14	21	21
467 616	✓	✓	18	14	18	8	10	8	21	21
101 053	✓	✓	18	15	15	8	13	14	21	24
100 582	✓	✓	18	15	18	8	13	8	21	24
585 013*	✓	✓	18	16	14	8	10	14	21	21
585 020	✓	✓	18	16	16	8	10	14	21	21
467 623	✓	✓	18	16	18	9	10	9	22	21
114 565	✓	✓	18	18	12	10	10	18	23	23
585 037	✓	✓	18	18	14	10	10	16	23	23
102 890	✓	✓	18	18	15	10	10	16	23	23
585 044*	✓	✓	18	18	16	10	10	16	23	23
100 612	✓	✓	18	18	18	10	11	10	23	24
104 689	✓	✓	18	22	18	15	13	15	28	29
104 733	✓	✓	22	12	22	8	15	8	24	24
592 585*	✓	✓	22	14	18	9	12	15	25	23
467 630	✓	✓	22	14	22	9	12	9	25	23
101 725	✓	✓	22	15	15	9	12	17	25	23

Cu = zaistenie kvality pre d12 – 54

* = dodávka len do vyčerpania skladových zásob

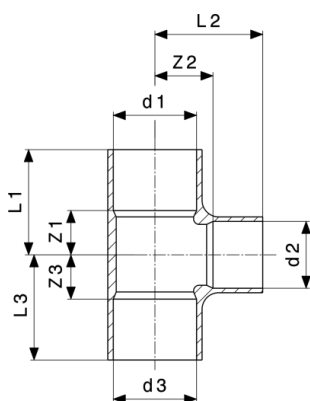

T-kus
- med'
model 95130

artikel	Cu	NF	d1	d2	d3	Z1	Z2	Z3	L1	L2
102 944	✓	✓	22	15	18	9	12	7	25	23
100 445	✓	✓	22	15	22	9	12	9	25	23
585 051	✓	✓	22	16	16	9	12	18	25	23
585 068*	✓	✓	22	16	18	9	12	16	25	23
467 647	✓	✓	22	16	22	10	12	10	26	23
105 297	✓	✓	22	18	15	11	14	11	27	27
585 075*	✓	✓	22	18	16	11	14	21	27	27
103 217	✓	✓	22	18	18	11	14	19	27	27
101 497	✓	✓	22	18	22	11	14	11	27	27
585 082	✓	✓	22	22	14	12	12	22	28	28
102 456	✓	✓	22	22	15	12	12	22	28	28
585 099*	✓	✓	22	22	16	12	12	22	28	28
104 702	✓	✓	22	22	18	12	12	20	28	28
100 476	✓	✓	22	22	22	12	12	12	28	28
105 204	✓	✓	22	28	22	20	15	20	36	34
114 183	✓	✓	28	12	28	10	20	10	29	29
106 737	✓	✓	28	15	22	11	18	20	30	29
101 619	✓	✓	28	15	28	10	18	10	29	29
114 947	✓	✓	28	18	18	12	18	24	31	31
109 219	✓	✓	28	18	22	12	18	21	31	31
102 852	✓	✓	28	18	28	10	18	10	29	31
112 943*	✓	✓	28	22	15	12	18	26	31	34
122 119	✓	✓	28	22	18	12	18	24	31	34
103 248	✓	✓	28	22	22	12	18	21	31	34
101 282	✓	✓	28	22	28	12	18	12	31	34

Cu = zaistenie kvality pre d12 – 54

* = dodávka len do vyčerpania skladových zásob

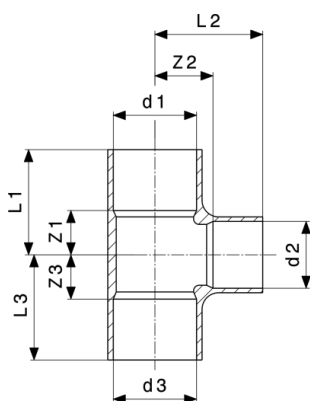

T-kus
- med'
model 95130

artikel	Cu	NF	d1	d2	d3	Z1	Z2	Z3	L1	L2
109 424	✓	✓	28	28	15	15	16	29	34	35
113 032	✓	✓	28	28	18	15	16	27	34	36
106 232	✓	✓	28	28	22	15	16	24	34	35
101 022	✓	✓	28	28	28	15	18	15	34	37
115 760	✓	✓	28	35	28	20	18	20	39	41
107 291	✓	✓	35	15	35	10	24	10	33	35
109 899	✓	✓	35	18	35	11	23	11	34	36
123 673	✓	✓	35	22	22	15	21	29	38	37
113 599	✓	✓	35	22	28	15	21	26	38	37
104 375	✓	✓	35	22	35	13	21	13	36	37
122 676*	✓	✓	35	28	22	23	19	16	41	42
110 727	✓	✓	35	28	28	18	23	28	41	42
105 808	✓	✓	35	28	35	16	23	16	39	42
121 235	✓	✓	35	35	22	21	22	35	44	45
117 580	✓	✓	35	35	28	21	22	32	44	45
104 184	✓	✓	35	35	35	19	22	19	42	45
118 556	✓	✓	42	15	42	13	28	13	40	39
125 479	✓	✓	42	18	42	15	26	15	42	39
111 595	✓	✓	42	22	42	16	26	16	43	42
110 383	✓	✓	42	28	42	18	26	18	45	45
122 591*	✓	✓	42	35	35	23	26	34	50	49
113 711	✓	✓	42	35	42	23	26	23	50	49
108 236	✓	✓	42	42	42	26	25	26	53	52
118 792	✓	✓	54	22	54	18	33	18	50	49
117 467	✓	✓	54	28	54	18	34	18	50	53

Cu = zaistenie kvality pre d12 – 54

* = dodávka len do vyčerpania skladových zásob

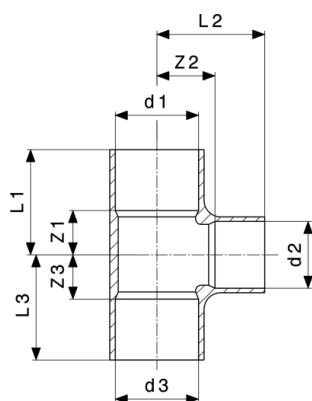

T-kus
- med'
model 95130

artikel	Cu	NF	d1	d2	d3	Z1	Z2	Z3	L1	L2
117 818	✓	✓	54	35	54	25	33	25	57	56
119 652	✓	✓	54	42	54	26	34	26	58	61
110 819	✓	✓	54	54	54	32	33	32	64	65
595 227*			64,0	42	64,0	28	42	28	55	64
595 234*			64,0	54	64,0	31	37	31	64	69
131 722			64,0	64,0	64,0	36	36	36	69	69
595 357*			76,1	54	76,1	29	42	29	63	74
595 364*			76,1	64,0	76,1	28	55	28	67	76
135 911			76,1	76,1	76,1	41	46	41	75	80
634 292*			88,9	54	88,9	33	47	33	71	79
595 241*			88,9	64,0	88,9	38	48	38	76	81
595 371*			88,9	76,1	88,9	44	44	44	81	83
137 021			88,9	88,9	88,9	60	60	60	99	99
151 003			108,0	108,0	108,0	60	60	60	107	107

artikel	Cu	NF	d1	d2	d3	L3
107 475			6	6	6	11
128 968			8	6	8	13
105 747		✓	8	8	8	13
120 009			10	6	10	13
104 092		✓	10	10	10	14
136 635		✓	12	8	12	16
109 745		✓	12	10	12	16
101 435	✓	✓	12	12	12	16
584 412*	✓	✓	14	12	12	23
467 586	✓	✓	14	12	14	19

Cu = zaistenie kvality pre d12 – 54

* = dodávka len do vyčerpania skladových zásob

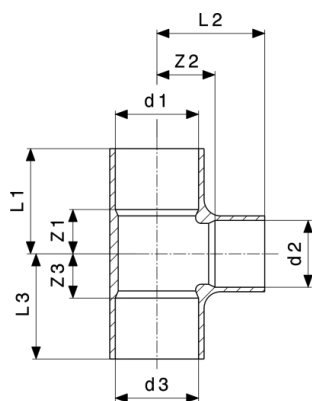

T-kus
- med' model 95130

artikel	Cu	NF	d1	d2	d3	L3
584 429*	✓	✓	14	14	12	24
467 562	✓	✓	14	14	14	19
584 436*	✓	✓	14	16	14	20
120 245		✓	15	8	15	19
106 355		✓	15	10	15	19
103 569	✓	✓	15	12	12	23
101 848	✓	✓	15	12	15	19
104 863	✓	✓	15	15	12	24
100 131	✓	✓	15	15	15	19
103 200	✓	✓	15	18	15	24
105 143	✓	✓	15	22	15	27
584 443*	✓	✓	16	12	14	25
467 593	✓	✓	16	12	16	19
584 962*	✓	✓	16	14	12	25
584 955	✓	✓	16	14	14	24
467 609	✓	✓	16	14	16	19
467 579	✓	✓	16	16	16	20
584 979	✓	✓	16	18	14	27
584 986*	✓	✓	16	18	16	24
120 122	✓	✓	18	12	12	25
107 413	✓	✓	18	12	15	25
103 606	✓	✓	18	12	18	21
584 993	✓	✓	18	14	14	25
585 006*	✓	✓	18	14	16	25
467 616	✓	✓	18	14	18	21

Cu = zaistenie kvality pre d12 – 54

* = dodávka len do vyčerpania skladových zásob

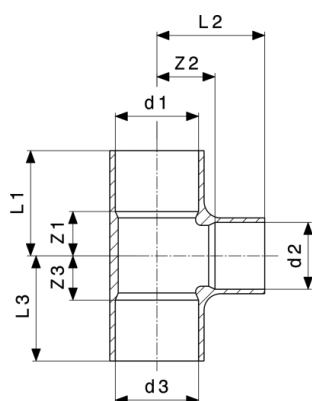

T-kus
- med' model 95130

artikel	Cu	NF	d1	d2	d3	L3
101 053	✓	✓	18	15	15	25
100 582	✓	✓	18	15	18	21
585 013*	✓	✓	18	16	14	25
585 020	✓	✓	18	16	16	25
467 623	✓	✓	18	16	18	22
114 565	✓	✓	18	18	12	27
585 037	✓	✓	18	18	14	27
102 890	✓	✓	18	18	15	27
585 044*	✓	✓	18	18	16	27
100 612	✓	✓	18	18	18	23
104 689	✓	✓	18	22	18	28
104 733	✓	✓	22	12	22	24
592 585*	✓	✓	22	14	18	28
467 630	✓	✓	22	14	22	25
101 725	✓	✓	22	15	15	28
102 944	✓	✓	22	15	18	28
100 445	✓	✓	22	15	22	25
585 051	✓	✓	22	16	16	29
585 068*	✓	✓	22	16	18	29
467 647	✓	✓	22	16	22	26
105 297	✓	✓	22	18	15	32
585 075*	✓	✓	22	18	16	32
103 217	✓	✓	22	18	18	32
101 497	✓	✓	22	18	22	27
585 082	✓	✓	22	22	14	33

Cu = zaistenie kvality pre d12 – 54

* = dodávka len do vyčerpania skladových zásob

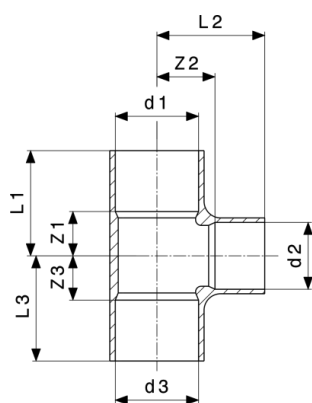

T-kus
- med'
model 95130

artikel	Cu	NF	d1	d2	d3	L3
102 456	✓	✓	22	22	15	33
585 099*	✓	✓	22	22	16	33
104 702	✓	✓	22	22	18	33
100 476	✓	✓	22	22	22	28
105 204	✓	✓	22	28	22	36
114 183	✓	✓	28	12	28	29
106 737	✓	✓	28	15	22	36
101 619	✓	✓	28	15	28	29
114 947	✓	✓	28	18	18	37
109 219	✓	✓	28	18	22	37
102 852	✓	✓	28	18	28	29
112 943*	✓	✓	28	22	15	37
122 119	✓	✓	28	22	18	37
103 248	✓	✓	28	22	22	37
101 282	✓	✓	28	22	28	31
109 424	✓	✓	28	28	15	40
113 032	✓	✓	28	28	18	40
106 232	✓	✓	28	28	22	40
101 022	✓	✓	28	28	28	34
115 760	✓	✓	28	35	28	39
107 291	✓	✓	35	15	35	33
109 899	✓	✓	35	18	35	34
123 673	✓	✓	35	22	22	45
113 599	✓	✓	35	22	28	45
104 375	✓	✓	35	22	35	36

Cu = zaistenie kvality pre d12 – 54

* = dodávka len do vyčerpania skladových zásob

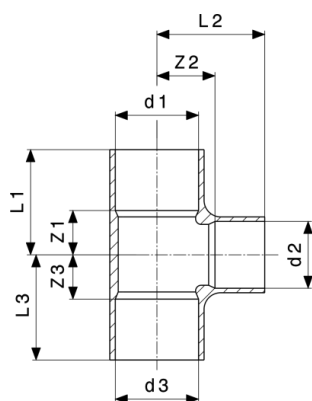

T-kus
- med' model 95130

artikel	Cu	NF	d1	d2	d3	L3
122 676*	✓	✓	35	28	22	49
110 727	✓	✓	35	28	28	47
105 808	✓	✓	35	28	35	39
121 235	✓	✓	35	35	22	51
117 580	✓	✓	35	35	28	51
104 184	✓	✓	35	35	35	42
118 556	✓	✓	42	15	42	40
125 479	✓	✓	42	18	42	42
111 595	✓	✓	42	22	42	43
110 383	✓	✓	42	28	42	45
122 591*	✓	✓	42	35	35	57
113 711	✓	✓	42	35	42	50
108 236	✓	✓	42	42	42	53
118 792	✓	✓	54	22	54	50
117 467	✓	✓	54	28	54	50
117 818	✓	✓	54	35	54	57
119 652	✓	✓	54	42	54	58
110 819	✓	✓	54	54	54	64
595 227*			64,0	42	64,0	55
595 234*			64,0	54	64,0	64
131 722			64,0	64,0	64,0	69
595 357*			76,1	54	76,1	63
595 364*			76,1	64,0	76,1	67
135 911			76,1	76,1	76,1	75
634 292*			88,9	54	88,9	71

Cu = zaistenie kvality pre d12 – 54

* = dodávka len do vyčerpania skladových zásob

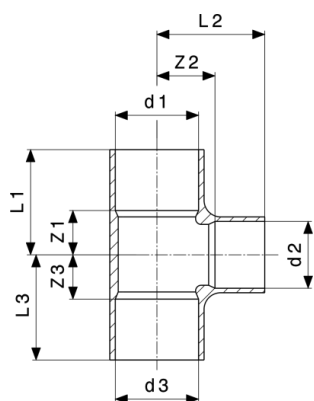

T-kus
- med'
model 95130

artikel	Cu	NF	d1	d2	d3	L3
595 241*			88,9	64,0	88,9	76
595 371*			88,9	76,1	88,9	81
137 021			88,9	88,9	88,9	99
151 003			108,0	108,0	108,0	107

Cu = zaistenie kvality pre d12 – 54

* = dodávka len do vyčerpania skladových zásob

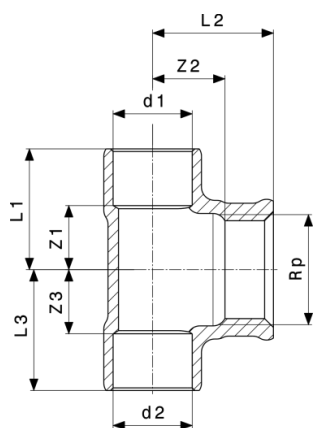

T-kus
- červený bronz
model 94130G

artikel	d1	Rp	d2	Z1	Z2	Z3	L1	L2	L3
150 600	12	½	12	13	7	13	22	22	22
475 772	14	½	14	12	8	12	23	23	23
131 029	15	¾	15	10	6	10	21	18	21
102 401	15	½	15	12	8	12	23	23	23
475 789	16	½	16	12	10	12	23	25	23
140 823*	18	¾	18	11	7	11	23	18	23
103 767	18	½	18	12	8	12	25	23	25
157 999	18	¾	18	17	9	17	30	25	30

* = dodávka len do vyčerpania skladových zásob

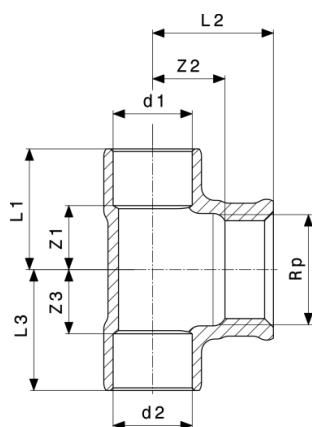

T-kus
- červený bronz
model 94130G

artikel	d1	Rp	d2	Z1	Z2	Z3	L1	L2	L3
119 195	22	¾	22	11	9	11	26	20	26
101 978	22	½	22	11	10	11	27	25	27
109 141	22	¾	22	17	10	17	32	27	32
103 453	28	½	28	14	14	14	33	29	33
112 035	28	¾	28	15	15	15	34	31	34
258 955	28	1	28	20	13	20	39	32	39
152 734	35	½	35	13	12	13	36	27	36
123 390	35	¾	35	15	12	15	39	29	39
136 734*	35	1¼	35	26	24	26	49	45	49
157 678*	42	1½	42	26	16	26	53	37	53

* = dodávka len do vyčerpania skladových zásob

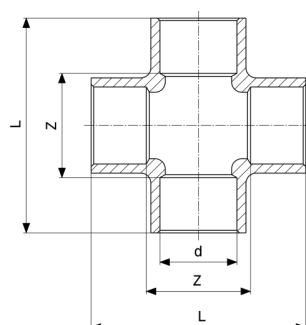

Křížový kus
- červený bronz
model 94180

artikel	d	Z	L
138 851	15	20	42
134 464	18	24	50
121 884	22	27	58
135 508	28	34	71

Z = rozmer Z

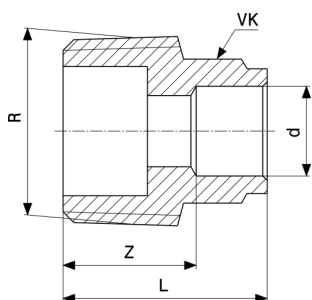

Prechodový kus
- červený bronz
model 94243G

artikel	d	R	Z	L	VK
151 614	8	¼	12	19	17
145 002	8	⅜	12	20	12
136 673	10	¼	11	20	14
114 060	10	⅜	11	19	13
112 400	10	½	15	23	14
132 620	12	¼	12	21	16
101 152	12	⅜	12	21	16
101 398	12	½	14	23	16
467 746	14	⅜	14	25	18
467 739	14	½	14	25	18
101 657	15	⅜	13	24	19
100 025	15	½	15	26	18
102 234	15	¾	16	27	19
467 753	16	½	14	26	20
467 760	16	¾	15	26	20
100 650	18	½	15	28	21
101 039	18	¾	13	26	21
101 749	22	½	17	33	26
100 322	22	¾	16	32	26
100 889	22	1	16	32	26
121 228	28	½	18	37	32
102 913	28	¾	18	37	32
100 285	28	1	18	37	32
105 839	28	1¼	19	40	32
107 109	35	1	22	45	39
102 661	35	1¼	21	44	42
174 484	35	1½	12	35	42

Z = rozměr Z

VK = velikost klíče

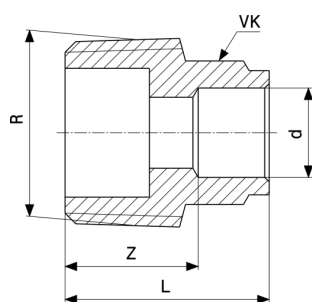

Prechodový kus
- červený bronz
model 94243G

artikel	d	R	Z	L	VK
141 905	42	1¼	26	53	48
106 638	42	1½	21	48	48
258 481	42	2	15	42	48
169 305	54	1½	28	60	61
109 196	54	2	30	62	61
138 202	64,0	2½	24	57	71
137 236	76,1	2½	34	68	83
140 007	88,9	3	41	79	97
159 634	108,0	4	48	96	119

Z = rozmer Z

VK = veľkosť kľúča

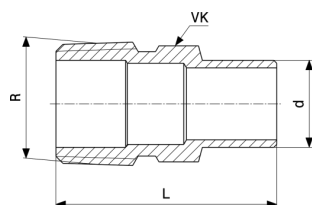

Prechodový kus
- červený bronz
model 94280G

artikel	d	R	L	VK
116 040	15	½	38	19
120 221*	18	½	40	21
131 166	22	½	44	24
117 894	22	¾	44	25
126 940*	28	1	51	31
140 946*	35	1¼	60	40
142 841*	42	1½	61	48

VK = veľkosť kľúča

* = dodávka len do vyčerpania skladových zásob

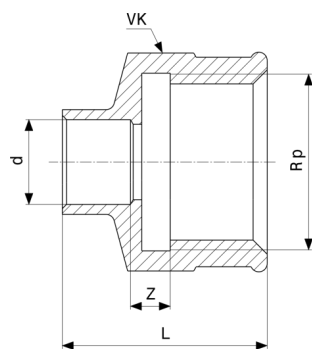

Prechodový kus
- červený bronz
model 94270G

artikel	d	Rp	Z	L	VK
118 976	10	¼	1	20	17
118 051	10	⅜	1	21	21
119 515	10	½	1	25	25
105 259	12	⅜	2	22	21
104 214	12	½	1	25	25
475 758	14	½	2	28	25
101 787	15	⅜	2	24	21
100 254	15	½	2	28	25
104 771	15	¾	2	29	30
475 765	16	½	2	28	25
100 940	18	½	2	30	25
102 180	18	¾	2	31	30
101 664	22	½	2	33	25
100 728	22	¾	1	34	30
102 470	22	1	1	36	38
104 139	28	¾	2	37	30
100 964	28	1	2	40	38
107 192	28	1¼	4	44	47
165 864	35	¾	0	40	34
107 857	35	1	1	43	40
108 267	35	1¼	6	51	48
163 419	42	1¼	6	55	49
117 597	42	1½	4	53	53
160 586	54	2	3	61	66
144 418	64,0	2½	4	66	83

Z = rozměr Z

VK = velikost klíče

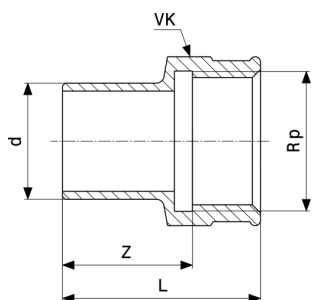

Zásuvný kus
- červený bronz
model 94246G

artikel	d	Rp	Z	L	VK
117 917	12	3/8	14	26	21
119 669	12	1/2	17	32	26
118 549	15	3/8	16	27	21
106 553	15	1/2	17	32	25
111 274	18	1/2	18	33	25
132 873*	18	3/4	20	36	31
112 455	22	1/2	21	36	25
118 846	22	3/4	21	38	31
131 838	28	3/4	24	41	31
117 849	28	1	25	45	38
133 252*	35	1 1/4	37	58	49

Z = rozmer Z

VK = veľkosť kľúča

* = dodávka len do vyčerpania skladových zásob

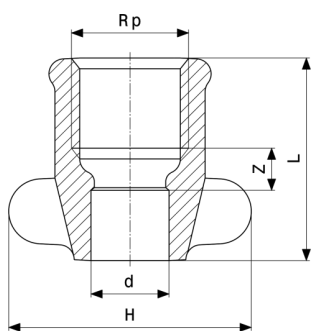

Prechodový kus
- červený bronz
model 94270GF

artikel	d	Rp	Z	L	v
103 880	15	1/2	6	32	40

Z = rozmer Z

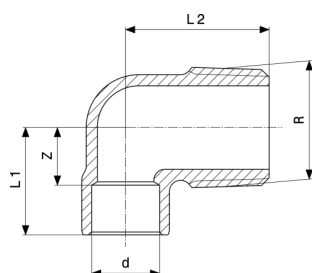

Prechodové koleno 90°
- červený bronz
model 94092G

artikel	d	R	Z	L1	L2
103 910	12	3/8	9	18	23
108 687	12	1/2	10	19	26
467 715	14	1/2	12	23	29
106 577	15	3/8	10	21	27
100 568	15	1/2	10	21	28
467 722	16	1/2	12	23	29
107 635	18	1/2	18	32	30
133 108	18	3/4	14	27	31
136 307	22	1/2	11	27	33
107 208	22	3/4	14	29	33
144 067	22	1	17	33	39
131 739	28	3/4	18	33	38
149 970	28	1	19	38	46
138 691	35	1 1/4	22	45	45

Z = rozmer Z

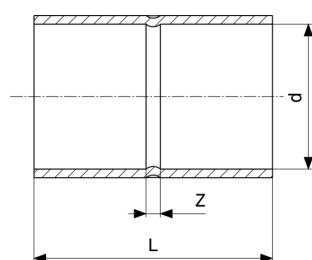

Spojka
- meď
model 95270

artikel	Cu	d	Z	L
108 717		6	1	13
107 093		8	1	15
102 357		10	1	17
100 872	✓	12	2	19

Cu = zaistenie kvality pre d12 – 54

Z = rozmer Z

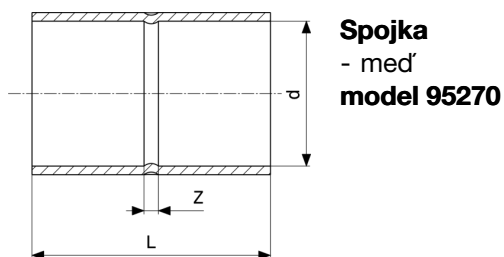

Spojka
- meď
model 95270

artikel	Cu	d	Z	L
467 654	✓	14	2	23
100 117	✓	15	2	23
467 661	✓	16	2	23
100 469	✓	18	2	27
100 353	✓	22	2	32
100 698	✓	28	2	38
102 616	✓	35	2	48
105 433	✓	42	2	56
106 744	✓	54	2	66
124 038		64,0	5	70
127 862		76,1	4	72
128 319		88,9	5	80
146 481		108,0	4	100

Cu = zaistenie kvality pre d12 – 54

Z = rozmer Z

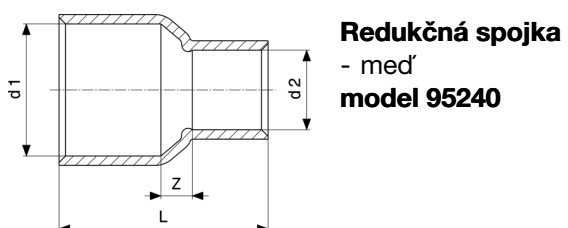

Redukčná spojka
- meď
model 95240

artikel	Cu	d1	d2	Z	L
142 872*		8	6	5	17
121 082		10	6	2	16
121 150		10	8	2	19
120 504		12	8	5	24
107 420		12	10	4	20

Cu = zaistenie kvality pre d12 – 54

Z = rozmer Z

* = dodávka len do vyčerpania skladových zásob

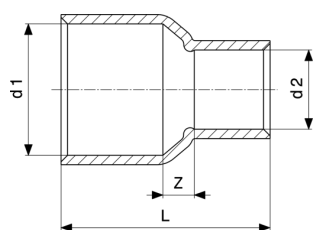

Redukčná spojka
- meď
model 95240

artikel	Cu	d1	d2	Z	L
585 136		14	10	4	23
464 301	✓	14	12	4	23
110 154		15	10	5	23
102 524	✓	15	12	5	26
464 318	✓	16	12	6	25
464 325	✓	16	14	4	25
106 874	✓	18	12	7	29
464 332	✓	18	14	6	29
101 176	✓	18	15	4	27
464 349	✓	18	16	4	27
110 758	✓	22	12	9	36
464 356	✓	22	14	8	34
101 565	✓	22	15	7	37
464 363	✓	22	16	7	33
101 602	✓	22	18	6	35
105 037	✓	28	15	12	44
585 143	✓	28	16	8	38
106 256	✓	28	18	7	42
102 111	✓	28	22	5	43
109 738	✓	35	22	11	50
105 334	✓	35	28	9	52
121 280	✓	42	22	23	67
117 269	✓	42	28	13	59
111 687	✓	42	35	10	60
124 076	✓	54	28	24	77
120 788	✓	54	35	14	69
116 118	✓	54	42	11	70
594 374		64,0	54	12	77

Cu = zaistenie kvality pre d12 – 54

Z = rozmer Z

* = dodávka len do vyčerpania skladových zásob

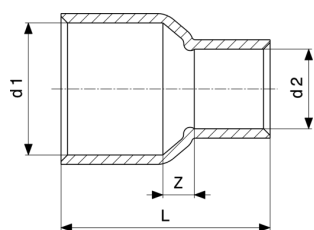

Redukčná spojka
- meď
model 95240

artikel	Cu	d1	d2	Z	L
634 278*		76,1	54	25	90
594 381*		76,1	64,0	14	80
594 398*		88,9	76,1	15	86
594 404*		108,0	88,9	20	105

Cu = zaistenie kvality pre d12 – 54

Z = rozmer Z

* = dodávka len do vyčerpania skladových zásob

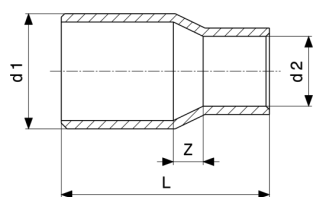

Redukčný kus
- meď
model 95243

artikel	Cu	d1	d2	Z	L
124 540		10a	6	3	18
119 805		10a	8	1	16
123 796		12a	6	4	21
116 187		12a	8	2	20
104 290		12a	10	1	19
105 983		15a	10	3	23
101 060	✓	15a	12	2	24
465 681	✓	16a	12	2	22
465 698	✓	16a	14	3	25
104 566	✓	18a	12	3	27
465 704	✓	18a	14	3	27
100 520	✓	18a	15	3	29
465 711	✓	18a	16	6	33
108 298	✓	22a	12	6	33
465 728	✓	22a	14	6	33

Cu = zaistenie kvality pre d12 – 54

Z = rozmer Z

* = dodávka len do vyčerpania skladových zásob

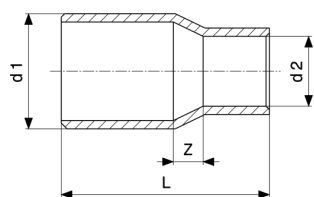

Redukčný kus
- meď
model 95243

artikel	Cu	d1	d2	Z	L
100 841	✓	22a	15	5	34
465 735	✓	22a	16	6	33
100 780	✓	22a	18	4	35
118 013	✓	28a	12	10	39
585 112	✓	28a	14	9	39
103 156	✓	28a	15	8	39
585 129	✓	28a	16	9	39
103 637	✓	28a	18	6	39
101 015	✓	28a	22	6	42
115 296	✓	35a	15	11	47
115 180	✓	35a	18	9	47
105 792	✓	35a	22	7	48
103 118	✓	35a	28	5	49
133 313*	✓	42a	15	15	55
116 392	✓	42a	22	11	56
110 260	✓	42a	28	8	56
106 935	✓	42a	35	5	57
118 648	✓	54a	28	15	67
115 852	✓	54a	35	11	68
112 530	✓	54a	42	8	69
594 169*		64,0a	35	19	78
594 176		64,0a	42	15	79
126 261		64,0a	54	2	75
594 190*		76,1a	35	24	86
594 183		76,1a	42	21	86
127 732		76,1a	54	12	82
594 206		76,1a	64,0	10	79
634 308		88,9a	54	21	96
594 237		88,9a	64,0	16	92

Cu = zaistenie kvality pre d12 – 54

Z = rozmer Z

* = dodávka len do vyčerpania skladových zásob

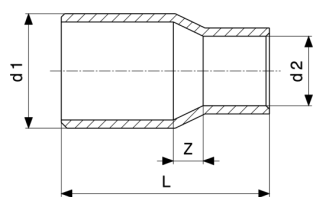

Redukčný kus
- meď
model 95243

artikel	Cu	d1	d2	Z	L
132 866		88,9a	76,1	4	87
594 213		108,0a	64,0	25	111
594 220		108,0a	76,1	19	107
150 709		108,0a	88,9	15	103

Cu = zaistenie kvality pre d12 – 54

Z = rozmer Z

* = dodávka len do vyčerpania skladových zásob

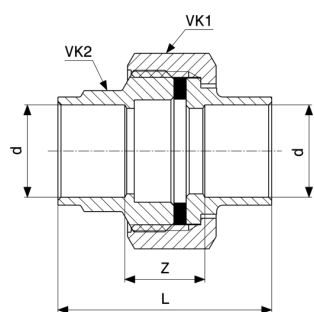

Skrutkový spoj
- červený bronz
model 94330

artikel	d	Z	L	VK1	VK2
110 239	15	13	35	29	19
122 249	18	14	40	29	22
116 583	22	14	45	36	26
154 196	28	18	55	46	32
176 174	35	22	68	52	40

Z = rozmer Z

VK = veľkosť kľúča

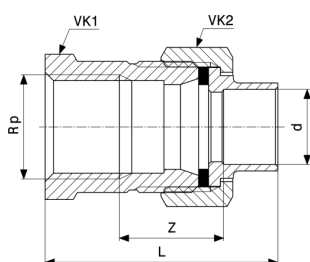

Prechodový skrutkový spoj
- červený bronz, mosadz
model 94330G

artikel	d	Rp	Z	L	VK1	VK2
113 421	15	½	21	47	29	27
120 856	18	½	22	50	29	27
117 399	22	¾	22	54	36	34
119 478	28	1	21	59	46	44

Z = rozmer Z

VK = veľkosť kľúča

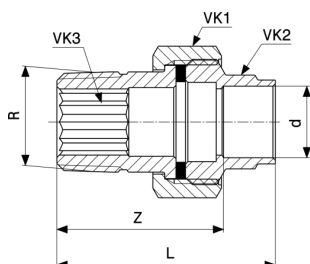

Prechodový skrutkový spoj
- červený bronz, mosadz
model 94331G

artikel	d	R	Z	L	VK1	VK2	VK3
109 806	15	½	35	46	29	19	12
120 146	18	½	35	48	29	22	12
112 967	22	¾	38	54	36	26	17
133 535	28	1	44	63	46	32	22
220 839	35	1¼	51	74	52	35	

Z = rozmer Z

VK = veľkosť kľúča

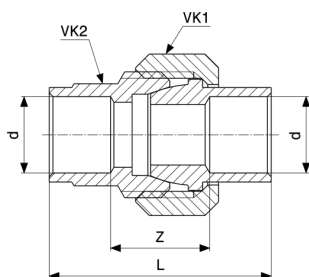

Skrutkový spoj
- červený bronz
model 94340

artikel	d	Z	L	VK1	VK2
132 033	10	13	30	19	13
151 645	12	12	30	23	16
103 699	15	13	35	29	19
124 434	18	14	40	29	22
104 399	22	13	45	36	26
107 604	28	17	54	46	32
114 695	35	20	66	52	40
125 899	42	21	76	59	49
148 256*	54	27	91	75	61

Z = rozmer Z

VK = veľkosť kľúča

* = dodávka len do vyčerpania skladových zásob

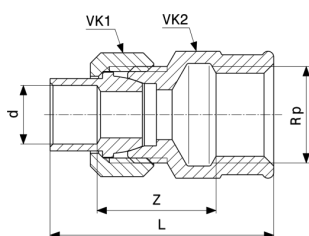

Prechodový skrutkový spoj
- červený bronz alebo kremíkový bronz, mosadz
model 94340G

artikel	d	Rp	Z	L	VK1	VK2
163 051*	12	½	17	41	23	25
122 683*	15	¾	15	38	29	22
103 422	15	½	21	47	29	27
110 390	15	¾	20	47	29	31
106 690	18	½	21	49	29	27
109 295	18	¾	20	49	29	31
101 527	22	¾	21	53	36	34
105 310	22	1	23	58	36	40

Z = rozmer Z

VK = veľkosť kľúča

* = dodávka len do vyčerpania skladových zásob

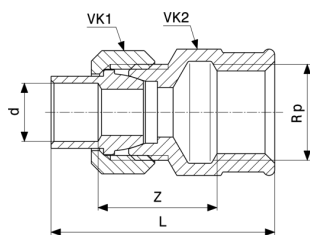

Prechodový skrutkový spoj
 - červený bronz alebo kremíkový bronz, mosadz
model 94340G

artikel	d	Rp	Z	L	VK1	VK2
103 002	28	1	20	58	46	44
107 918	35	1¼	25	70	52	50
115 937	42	1½	23	72	59	55
125 325	54	2	23	81	75	66

Z = rozmer Z

VK = veľkosť kľúča

* = dodávka len do vyčerpania skladových zásob

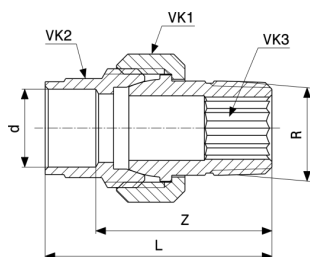

Prechodový skrutkový spoj
 - červený bronz alebo kremíkový bronz, mosadz
model 94341G

artikel	d	R	Z	L	VK1	VK2	VK3
118 921	12	¾	29	38	23	16	8
147 099	12	½	36	45	29	16	12
115 883	15	¾	31	42	23	19	8
102 128	15	½	33	44	29	19	12
122 959	15	¾	39	50	36	19	17
109 042	18	½	34	47	29	22	12
109 547	18	¾	38	51	36	22	17
101 558	22	¾	36	52	36	26	17
109 080	22	1	44	59	46	26	22
103 705	28	1	41	60	46	32	22
108 427	35	1¼	45	68	52	40	
118 327	42	1½	51	78	59	49	
129 620	54	2	54	86	75	61	

Z = rozmer Z

VK = veľkosť kľúča

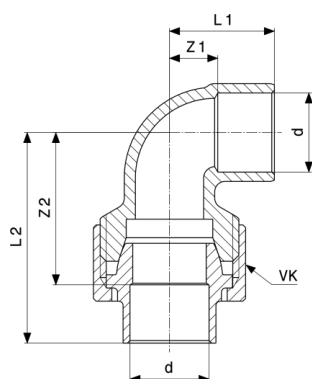

Prechodový skrutkový spoj 90°
- červený bronz
model 94096

artikel	d	Z1	Z2	L1	L2	VK
123 499*	15	9	30	20	41	29
134 815*	18	12	32	25	45	29
133 276*	22	14	36	30	52	36
146 368	28	18	42	37	60	46

VK = velikost klíče

* = dodávka len do vyčerpania skladových zásob

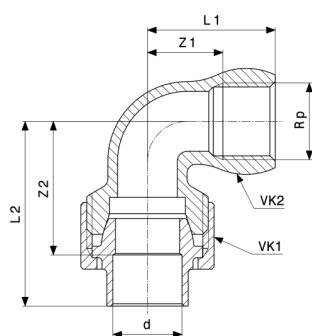

Prechodový skrutkový spoj 90°
- červený bronz alebo kremíkový bronz, mosadz
model 94096G

artikel	d	Rp	Z1	Z2	L1	L2	VK1	VK2
114 787	15	½	18	31	33	42	29	28
119 461	18	½	21	31	33	44	29	28
216 962	18	¾	23	39	39	52	36	33
107 338	22	¾	23	37	39	53	36	33
120 498	22	1	25	40	44	56	36	40
112 295	28	1	28	44	47	63	46	39
121 433*	35	1¼	35	50	57	73	52	48

VK = velikost klíče

* = dodávka len do vyčerpania skladových zásob

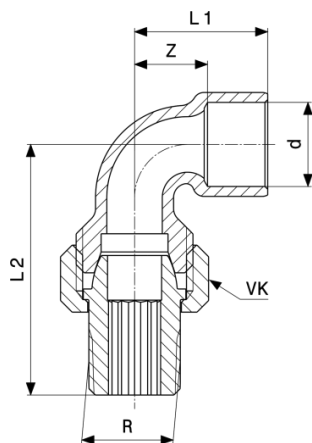

Prechodový skrutkový spoj 90°
 - červený bronz alebo kremíkový bronz, mosadz
model 94098G

artikel	d	R	Z	L1	L2	VK
120 979*	12	½	9	18	49	29
103 859	15	½	9	20	49	29
110 017	18	½	12	25	51	29
120 580	18	¾	12	25	59	36
114 909	22	¾	14	30	59	36
144 128	28	1	18	37	68	46
120 061*	35	1¼	22	45	76	52
144 098*	42	1½	24	51	85	59
146 450*	54	2	28	60	100	74

Z = rozmer Z

VK = veľkosť kľúča

* = dodávka len do vyčerpania skladových zásob

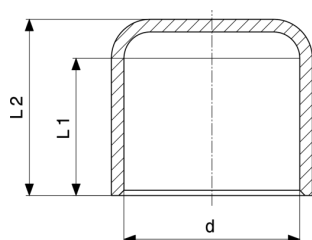

Viečko
 - meď
model 95301

artikel	d	L1	L2
121 273	8	7	9
108 892	10	8	10
104 450	12	9	11
467 678	14	11	13
101 466	15	11	13
467 685	16	11	13

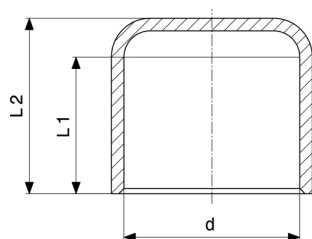

Viečko
- meď
model 95301

artikel	d	L1	L2
103 590	18	13	15
102 951	22	15	18
105 662	28	18	21
109 134	35	25	29
113 155	42	27	33
114 077	54	32	37
594 367	64,0	33	37

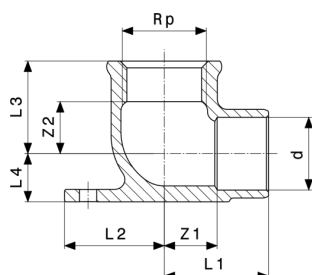

Nástenka
- červený bronz
model 94471G

artikel	d	Rp	Z1	Z2	L1	L2	L3	L4
103 958	12	½	13	5	22	25	20	9
101 275	15	½	13	7	24	25	22	10
106 393	18	½	13	8	26	25	23	12
113 216	18	¾	16	8	29	30	24	12
110 192	22	½	15	8	31	21	23	15
111 304	22	¾	17	10	33	21	27	15
151 812*	28	1	19	15	37	34	35	18

* = dodávka len do vyčerpania skladových zásob

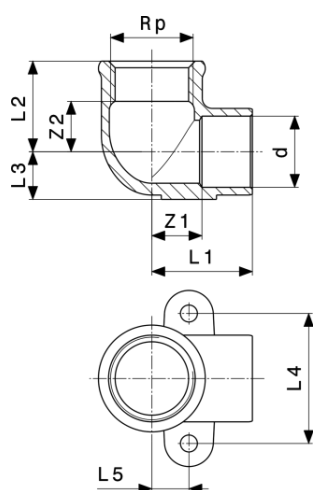

Nástenka
- červený bronz
model 94472G

artikel	d	Rp	Z1	Z2	L1	L2	L3	L4	L5
103 965	12	½	13	5	22	20	9	33	9
467 791	14	½	13	12	24	22	11	33	9
112 813	15	¾	10	6	21	18	11	34	0
100 223	15	½	12	7	23	22	10	33	9
467 807	16	½	13	11	24	22	11	33	9
102 210	18	½	13	8	26	23	12	33	9
113 490	22	¾	17	10	33	27	14	42	12

L = délka

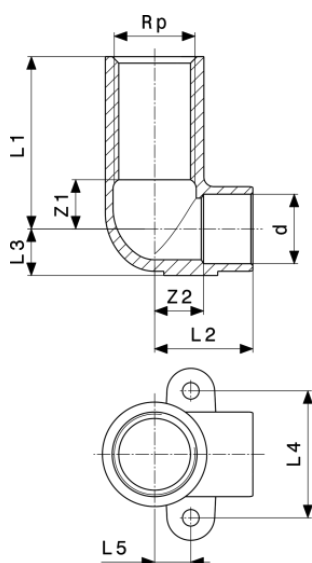

Nástenka
- červený bronz
model 94472GL

artikel	d	Rp	L	Z1	Z2	L1	L2	L3	L4	L5
105 129*	15	½	45	12	13	45	24	10	33	10

L = dĺžka

* = dodávka len do vyčerpania skladových zásob

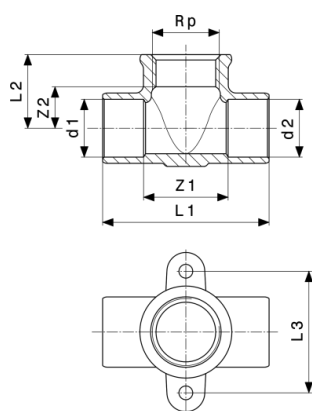

Nástenka T-kus
- červený bronz
model 94490G

artikel	d1	Rp	d2	Z1	Z2	L1	L2	L3
118 310	15	½	15	30	7	52	22	38
138 127*	18	½	18	26	8	52	23	38
122 287*	22	½	22	23	14	56	29	48

* = dodávka len do vyčerpania skladových zásob

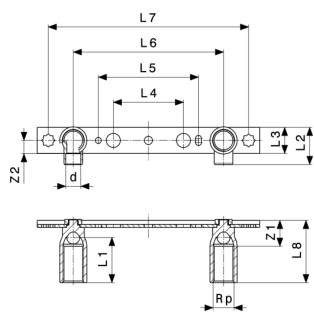
Gemini-montážna jednotka model 94476

artikel	d	Rp	L	rozstup	Z1	Z2	L1	L2	L3	L4
107 031	15	½	45	150/200	26	13	45	38	26	70
111 151	15	½	65	150/200	26	13	65	38	26	70

artikel	d	Rp	L	rozstup	L5	L6	L7	L8
107 031	15	½	45	150/200	100	150	200	63
111 151	15	½	65	150/200	100	150	200	83

L = dĺžka

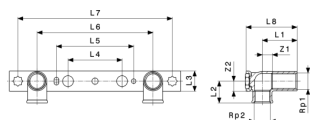
Gemini-montážna jednotka model 94478

artikel	Rp1	Rp2	L	rozstup	Z1	Z2	L1	L2	L3	L4
124 892	½	½	45	150/200	29	13	45	41	26	70

artikel	Rp1	Rp2	L	rozstup	L5	L6	L7	L8
124 892	½	½	45	150/200	100	150	200	67

L = dĺžka

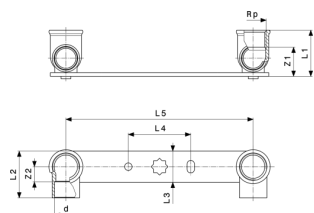
Gemini-montážna jednotka model 94476.0

artikel	d	Rp	rozstup	Z1	Z2	L1	L2	L3	L4	L5
123 628	12	½	150	17	13	32	34	25	25	50
101 091	15	½	150	20	12	35	36	25	25	50
108 021	18	½	150	22	12	37	38	25	25	50

L = dĺžka

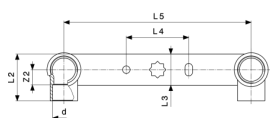
**Gemini-montážna jednotka
model 94476.0**

artikel	d	Rp	rozstup	L6	L7
123 628	12	½	150	125	150
101 091	15	½	150	125	150
108 021	18	½	150	125	150

L = dĺžka

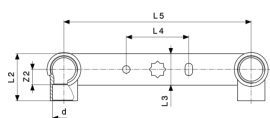
**Gemini-montážna jednotka
model 94476.05**

artikel	d	Rp	rozstup	Z1	Z2	L1	L2	L3	L4	L5
121 167	12	½	150	17	13	32	34	25	50	150
104 986	15	½	150	20	12	35	36	25	50	150

L = dĺžka

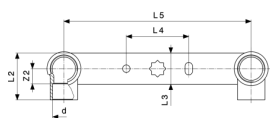
**Gemini-montážna jednotka
model 94476.05NOR**

artikel	d	Rp	rozstup	Z1	Z2	L1	L2	L3	L4	L5
111 441	12	¾	150	17	11	28	30	25	50	150
113 988	12	½	150	22	13	32	34	25	50	150
113 179	15	½	150	20	12	35	36	25	50	150

L = dĺžka

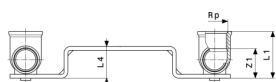
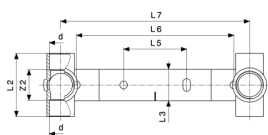

**Gemini-montážna jednotka
model 94476.09**

artikel	d	Rp	rozstup	Z1	Z2	L1	L2	L3	L4	L5
130 145*	15	½	150	19	26	34	48	25	25	50

artikel	d	Rp	rozstup	L6	L7
130 145*	15	½	150	125	150

L = dĺžka

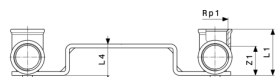
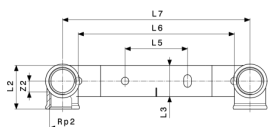
* = dodávka len do vyčerpania skladových zásob

**Gemini-montážna jednotka
model 94478.0**

artikel	Rp1	Rp2	rozstup	Z1	Z2	L1	L2	L3	L4	L5
118 754	½	½	150	29	15	44	38	25	25	50

artikel	Rp1	Rp2	rozstup	L6	L7
118 754	½	½	150	125	150

L = dĺžka

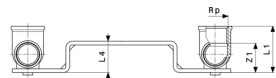
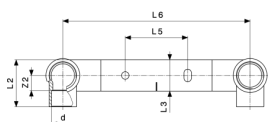
**Gemini-montážna jednotka
model 94476EX**

artikel	d	Rp	rozstup	Z1	Z2	L1	L2	L3	L4	L5
105 990	12	¾	120	17	10	28	30	25	21	40

artikel	d	Rp	rozstup	L6
105 990	12	¾	120	120

L = dĺžka

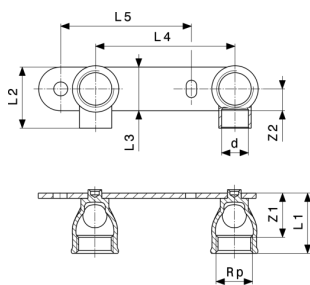

**Gemini-montážna jednotka
model 94476.2**

artikel	d	Rp	rozstup	Z1	Z2	L1	L2	L3	L4	L5
107 284	15	½	100	20	12	35	36	25	55	100

L = dĺžka

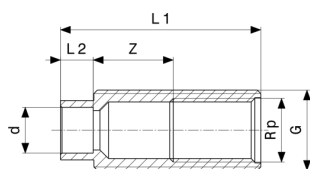

**Stenová priechodka
- červený bronz
model 3427.2**

artikel	d	L	Rp	G	Z	L1	L2
448 745	15	55	½	¾	25	66	11

L = dĺžka
Z = rozmer Z

Imprint

Viega GmbH & Co. KG

Viega Platz 1
57439 Attendorn
Germany
Phone: +49/2722/61-0
Fax: +49/2722/61-1566

The Viega GmbH & Co. KG is represented by the general partners: Viega Management B.V. (Managing directors: Michael Klenz, Sebastian Leigemann) and Viega Management GmbH (Managing directors: Michael Klenz, Sebastian Leigemann)

Balík Submittal Package predstavuje nezáväzné informácie, ktoré sú vám k dispozícii. Všetky obsahy balíka Submittal Package boli zostavované veľmi starostlivo. Napriek tomu nemôžeme zaručiť aktuálnosť, správnosť a úplnosť informácií. Balík Submittal Package nie je pri objednávke súčasťou predmetu plnenia zmluvy.